

PRODUCT CATALOGUE

OUR GLOBAL REACH

Our sales network is there for you in more than 50 countries. Thanks to our sales representation in China, USA and Poland, as well as our broad network of distributors, we are available whenever our products or services are required.



HEADQUARTERS

BROEN - Clorius
Skovvej 30
DK-5610 Assens
+45 77 32 31 30
mail@cloriuscontrols.com



SALES REPRESENTATION

BROEN - CLORIUS - CHINA

Room 1910-1911,
Unicom International Tower,
NO 547 West Tian Mu Road
Shanghai 200070
P.R. China
Tel: +86 21 33 030 279 //
+86 21 33 035 279

BROEN - CLORIUS - POLAND

BROEN SA
ul. Strefowa 19
58-200 Dzierżonów
Poland
Tel: +48 74 832 54 00

Premium flow management systems	4
A century of delivering quality	6
Preferred supplier to the maritime industry	7
Industries we serve	8
Solution overview	9
Product overview	10
Applications overview	12
Electric temperature controls	14
Pneumatic temperature controls	16
Standards & certificates	18
Valve Sizing	20
Frequently asked questions	21
CASE STUDY: Reduce up to 10% in fuel consumption	22
Our clients	24
Overview of Clorius Valves - Available standards for connections	26
Overview of Clorius actuators	28
SECTION 1 // CONTROL VALVES	30
// L - CONTROL VALVES	32
// M - CONTROL VALVES	78
// H - CONTROL VALVES	102
// G - CONTROL VALVES	126
SECTION 2 // THERMOSTATS	228
SECTION 3 // ELECTRIC ACTUATORS	242
SECTION 4 // ELECTRIC CONTROLLERS	262
SECTION 5 // PNEUMATIC ACTUATORS	272
SECTION 6 // PNEUMATIC CONTROLLERS & POSITIONERS	284
SECTION 7 // DIFFERENTIAL PRESSURE CONTROLS	304
SECTION 8 // PRESSURE REDUCING VALVES	314
SECTION 9 // ACCESSORIES	318
TERMS & CONDITIONS	334

PREMIUM FLOW MANAGEMENT SOLUTIONS

BROEN - Clorius- is a leading manufacturer of valves, actuators, and comprehensive control solutions supporting various marine and industrial applications. Aside from our extensive assortment of control valves and actuators, we provide tailored solutions, including electric, pneumatic, self-acting and direct-acting control systems to meet the specific requirements set by the customer.

Clorius' products are designed to meet the challenging requirements of our clients. Our products, constructed with premium materials ensure longer life cycle, minimal maintenance and lower cost of ownership.





**WE ARE SURPASSING EXPECTATIONS BY PROVIDING
THE BEST FLOW MANAGEMENT SOLUTIONS, THE
MOST EXPERIENCED PEOPLE, AND UNPARALLELED
APPLICATION KNOWLEDGE.**

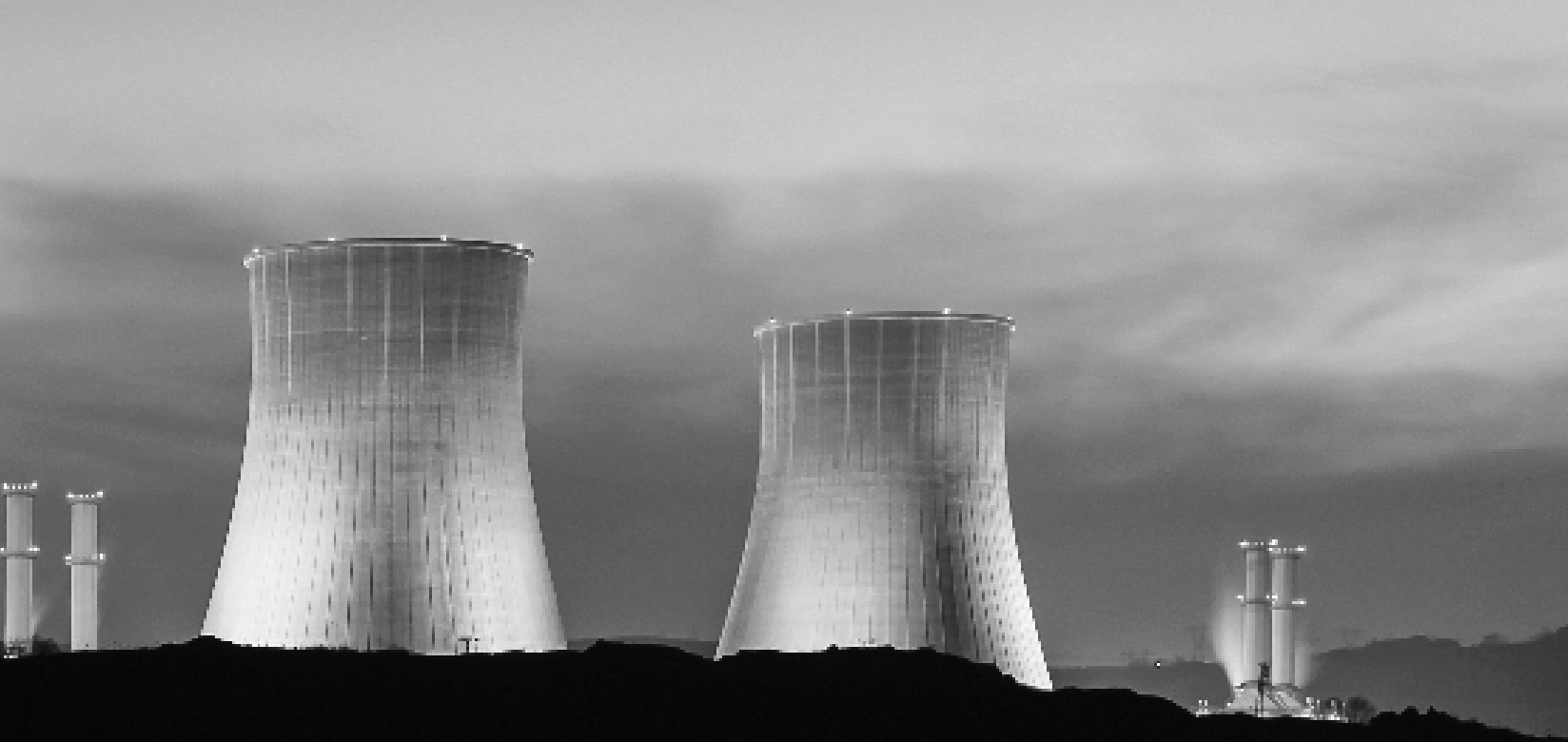

A CENTURY OF DELIVERING QUALITY

Clorius specializes in the development and production of equipment for monitoring, controlling and regulating heating, cooling and ventilation.

The product range consists of valves, thermostats, pressure differential regulators and electronic controllers. The products make up a complete range within our field of expertise. We have a long-standing tradition of delivery to the ship building industry, industrial applications as well as building heating and ventilation. This means that our products and services are developed in order to match the high requirements set by the maritime industry.

Our vision is to ensure the most reliable and economic solutions whilst meeting the challenging requirements set by our clients.

Clorius' products, constructed with premium materials ensure longer life cycle, minimal maintenance and lower cost of ownership.

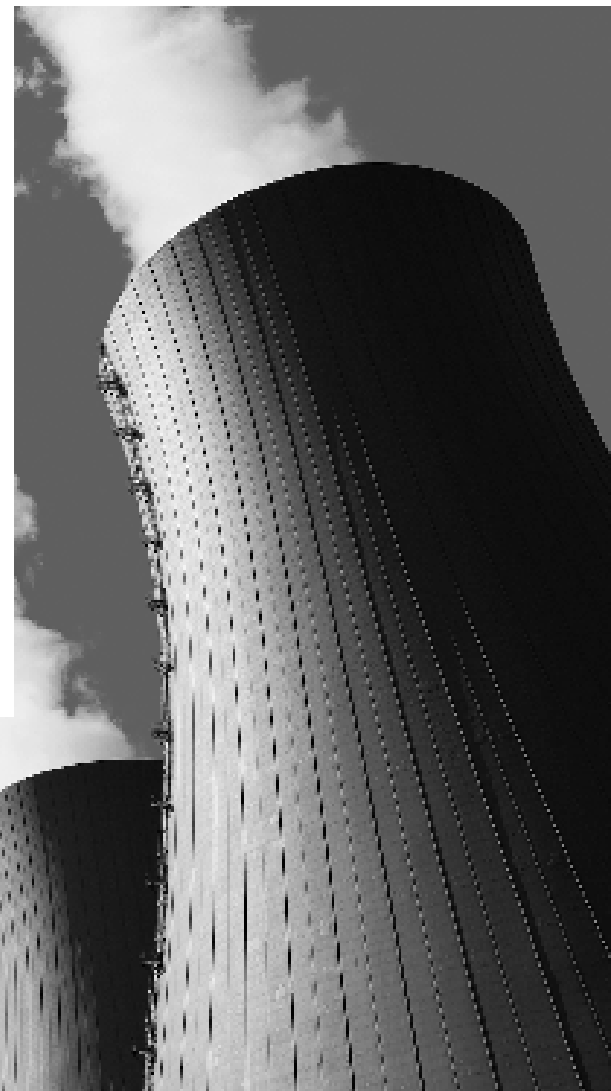

PREFERRED SUPPLIER TO THE MARITIME INDUSTRY

With roots in the maritime industry that go back to 1902, Clorius has become a preferred supplier of solutions for relatively simple as well as far more complex challenges. By working closely with our clients and their suppliers, Clorius adds value throughout the entire lifecycle of the ship. With our focus on quality we provide solutions that guarantee optimal use of the equipment and the vessel.

We take pride in being the preferred supplier to the maritime industry by offering customer-specific, value-driven and long-lasting solutions.

All Clorius Controls solutions are designed with extensive research and development and is supported by over 115 years of experience in the maritime industry.

This is acknowledged by the type approvals for our solutions from multiple classification authorities, including Germanischer Lloyds, DNV GL, ABS, RINA, RS, CCS, KR to name a few.

Clorius' marine products are designed to meet the challenging requirements of shipbuilders around the globe, by delivering premium quality valves and actuators for various marine applications. Their robust construction coupled with premium materials ensures longer life cycle for the vessels, minimal maintenance and lower cost of ownership.



INDUSTRIES WE SERVE

Clorius Controls caters to the specific needs of our clients by supplying premium and highly efficient flow management solutions, comprising of top-quality control valves, actuators and positioners. Our industry insight and knowledge is grounded in the identification of key issues that our client face as well as firsthand experience gained from serving clients throughout out 100-year-plus history.

OUR MARKETS



TYPICAL APPLICATIONS

- Main and auxiliary engine cooling systems
- Fuel and lubricating oil temperature control
- Tank heating and cleaning

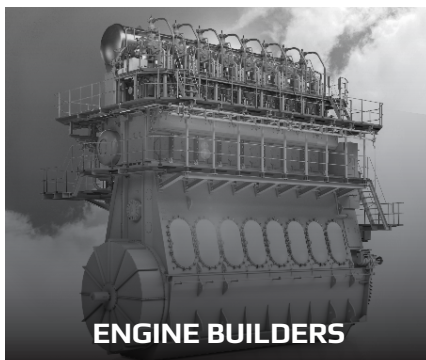

- Customer specific engineered valves for main and auxiliary engine cooling systems



- Cooling systems on Biomass, Oil & Gas and nuclear power plants
- Cooling water and lubricating oil temperature control on power units

SOLUTIONS OVERVIEW

Clorius Controls specializes in a control valve and actuator portfolio with the lowest cost of ownership for use in challenging conditions. As one of the leading control valve manufacturers, we are committed to providing premium industrial solutions to our clients.

Below are just a few of the configurations we currently produce and supply.

ELECTRIC

ELECTRIC ACTUATOR
3 POINT, ANALOG



For 2-way and 3-way valve up to DN 800. Actuators for linear and rotating valve types. Handle for manual control available

PNEUMATIC

PNEUMATIC ACTUATOR
SPRING CLOSE/OPEN POSITIONER



For 2-way and 3-way valve up to DN 800. Actuators for linear and rotating valve types. PI or alternatively PID pneumatic controllers.

SELF-ACTING

THERMOSTAT
DN15 - 150



For 2-way and 3-way valve up to DN 150. No external power needed. Narrow neutral zone (1.5 °C - 2.5 °C) compared to all other brands.

PRODUCT OVERVIEW

Quality is at the heart of who we are – it shows up in our people, our conversations and our products. Product quality is the foundation we stand on and this foundation is comprised of three key areas: Material, performance and craftsmanship.

Clorius Controls continually aims to develop our product portfolio by identifying the needs of the market and providing products and solutions of uncompromised quality. Our product range is divided into 5 different sections, offering an extensive range of equipment for monitoring and control of heating, cooling and ventilation systems.

Clorius valves are the preferred choice of the maritime industries, being installed in more than 1500 vessels within the last five years.

Simple, reliable and durable.

- Electric Control Valves
- Pneumatic Control Valves
- Self-acting temperature controls
- Self-acting pressure controls
- Controlling & Monitoring

OUR SOLUTIONS

SOLUTION 1



THERMOSTAT



2-WAY VALVE
DN 15/4 - 150

SOLUTION 2



THERMOSTAT



3-WAY VALVE
DN 15 - 150

SOLUTION 3



PRESSURE REDUCING
VALVE
DN 15 - 80

SOLUTION 4



DIFFERENTIAL PRESSURE
CONTROLS
DN 15 - 80

SOLUTION 5



ELECTRIC ACTUATOR
2 + 3 POINT, ANALOGUE

+



CONTROLLER
ER 202
ELECTRIC

+

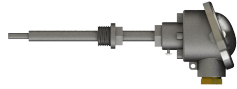

SENSOR PT100

2 WAY VALVE
DN 15/4 - 800 MM

SOLUTION 6



ELECTRIC ACTUATOR
SPRING CLOSE/OPEN

+



CONTROLLER
ER 202
ELECTRIC

+

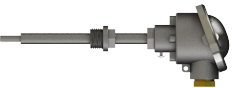

SENSOR PT100

2 WAY VALVE
DN 15/4 - 800 MM

SOLUTION 7



PNEUMATIC ACTUATOR
SPRING CLOSE/OPEN

+



CONTROLLER
PNEUMATIC



TRANSMITTER

2 WAY VALVE
DN 15/4 - 800 MM

SOLUTION 8



PNEUMATIC ACTUATOR
SPRING CLOSE/OPEN

+



CONTROLLER
PNEUMATIC



TRANSMITTER

3 WAY VALVE
DN 15 - 800 MM

SOLUTION 9



PNEUMATIC ACTUATOR
SPRING CLOSE/OPEN

+



CONTROLLER
ER 202
ELECTRIC

+

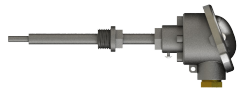

SENSOR PT100

2 WAY VALVE
DN 15/4 - 800 MM

SOLUTION 10



PNEUMATIC ACTUATOR
SPRING CLOSE/OPEN

+



CONTROLLER
ER 202
ELECTRIC

+

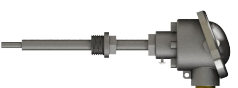

SENSOR PT100

3 WAY VALVE
DN 15 - 800 MM

APPLICATIONS OVERVIEW

Clorius Controls' control valves make up a uniquely integrated system of valve, actuator, positioner and process controller - working in perfect harmony for ideal results.

Clorius provides a comprehensive and carefully coordinated system of product solutions specifically tailored to your individual needs.

Possible applications include:

TYPICAL APPLICATIONS

MAIN ENGINE AND AUXILIARY ENGINE

- Jacket cooling water system
- Piston cooling
- Nozzle cooling
- Load and scavenging air cooling
- Lubricating oil cooling

OIL PREHEATING

- Fuel or diesel oil in storing, settling and servicing tank
- Preheating prior to separation and injection

HEAT EXCHANGERS

- Water heaters for radiator plant
- Water heaters for domestic plant
- Evaporators (production of fresh water)

TANK HEATING

- Bilge water tank
- Cargo tank
- Sludge tank
- FO drain tank
- FO overflow tank
- Asphalt tank

AIR CONDITIONING PLANT

- Preheating of air
- Reheating of air
- Cooling of air

Solutions are depending on the actual method required: 2 way with self-acting thermostat or with actuator, controller and sensor.

3 way valve (mixing or diverting) with self-acting thermostat or actuator, controller and sensor.

Actuators can be electrical, pneumatic or electro-pneumatic.

Hydraulic or electric/hydraulic actuators are optional solutions. Communication with central control system (RS 485 for controller type ER 2000)

Illustrations on the right side only displays a small fraction of the possible applications in our portfolio.

HEAT EXCHANGERS - Heating system for fresh water generation

TEMPERATURE CONTROLS

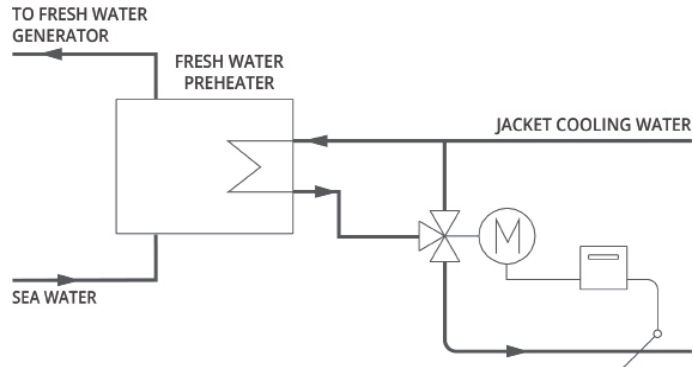

MAIN AND AUXILIARY ENGINE - Central cooling water system

TEMPERATURE CONTROLS

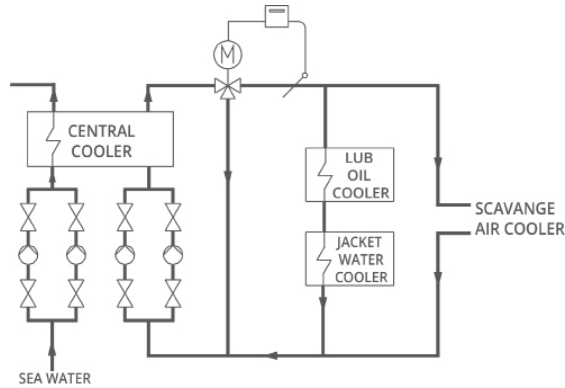

MAIN AND AUXILIARY ENGINE - Lubricating oil cooling

TEMPERATURE CONTROLS

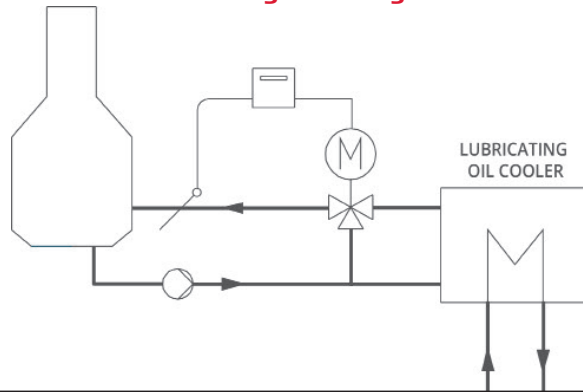

MAIN AND AUXILIARY ENGINE - Engine jacket cooling water system - electric

TEMPERATURE CONTROLS

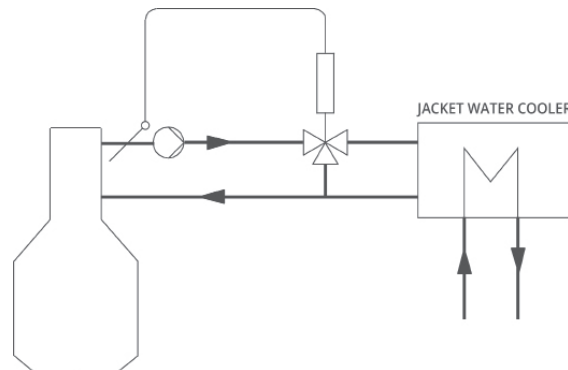

PRESSURE REDUCTION - Applicable for various media (eg. AIR, STEAM, LIQUID)

PRESSURE CONTROLS

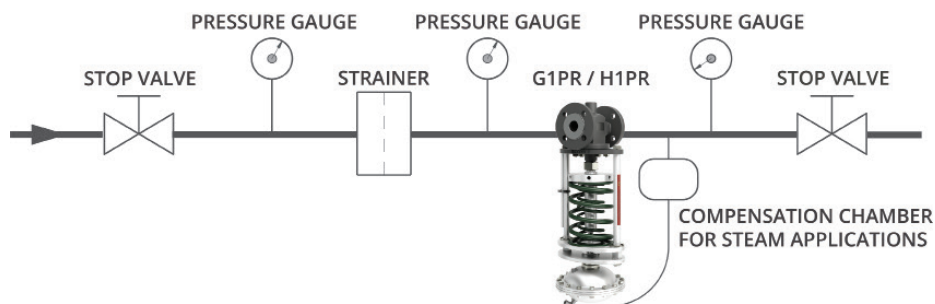

ELECTRIC TEMPERATURE CONTROLS

***ELECTRONIC SYSTEM** - The electronic temperature and pressure control system combines an electrically actuated three-way control valve with an electronic controller and essential temperature sensor.*

Microprocessor-based Controller of the type ER 2022 for electronic temperature control is used for constant temperature control. It is suitable for all heating and cooling control systems. The ER 2022 is a single loop controller which is intended for marine installations and other industrial applications - such as cooling water and lubricating oil installations, flow temperature control etc.

The ER 2022 controllers are designed for panel mounting and are fully programmable, which allows for uncomplicated system configuration.

The valve is designed for mixing and diverting media flows for large flow control systems.



SELECTING YOUR SOLUTION >>>

STEP 1
*Choose your valve
and actuator*

ELECTRIC ACTUATOR



3-WAY VALVE

STEP 2
Choose your controller

**PLC
PROGRAMMABLE
LOGIC CONTROLLER**



CONTROLLER ER 2022

STEP 3
Choose your sensor

SENSOR



PNEUMATIC TEMPERATURE CONTROLS

PNEUMATIC SYSTEM - The pneumatic temperature control system integrates a pneumatically actuated three-way control valve with a pneumatic controller and temperature sensor and a pneumatic-pneumatic positioner. The pneumatic system is especially suitable when there is lack of electricity or when a fail-safe system is required.

ELECTRO-PNEUMATIC SYSTEM

The electro-pneumatic temperature control system utilizes both electric and pneumatic technology, composed of a pneumatically actuated three-way control valve and electro-pneumatic positioner.

PERFECTED FOR HARSH ENVIRONMENTS

Clorius Controls' EPR/PPR electro-pneumatic & pneumatic-pneumatic positioner is a rugged control device especially suited for harsh environments and engineered to meet the highest and most demanding control performance that the process industries of today require.

The AD/ADHW pneumatic actuators are made according to the Scotch Yoke principle, which is characteristic for its high torque when required - at the beginning and at the end of each operation. This increases safety and reduces the energy consumption. The filter regulator, equipped with auto drain is protecting the positioner from dust, water and oil particles in the compressed air supply. With the backflow function it incorporates a mechanism to exhaust the air pressure in the outlet side reliably and quickly.



SELECTING YOUR SOLUTION >>>

STEP 1

Choose your valve, actuator and positioner



3-WAY VALVE

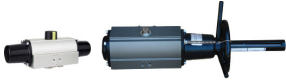

**PNEUMATIC ACTUATOR
TYPE AD/ADHW**



**PPR/EPR
POSITIONER**

STEP 2

Choose your air reduction valve/Filter



FILTER REGULATOR

STEP 3

Choose your controller

**PLC
PROGRAMMABLE
LOGIC CONTROLLER**



**PNEUMATIC
CONTROLLER**



**CONTROLLER ER 2000
OR ALTERNATIVE
ER 2022**

STEP 4

Choose your sensor



SENSOR

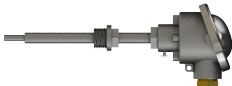



STANDARDS & CERTIFICATES

Clorius Controls routinely manufactures and tests its products to the most demanding customer specifications and recognized national and international industry standards.

A long-standing tradition of delivering to the shipbuilding industry means that products delivered by Clorius Controls A/S are developed to match the high requirements set by the maritime industry.

Since 1993 we have been ISO 9001 certified for development, manufacturing, sales and servicing of controls for buildings, industrial and marine applications.

Clorius' internal standards for excellence are reflected in how we conduct our daily business. Our valves can be delivered with certificates issued by various recognized ship classification societies, stating that the classification society has participated in pressure test of the valve.

We can also deliver valves with certificates in accordance to:

- EN 10.204 / 2.1
- EN 10.204 / 2.2
- EN 10.204 / 3.1

Furthermore, we conduct:

- Inspection and test plan
- Pressure and leakage test

Valves from Clorius Controls can be delivered in accordance with the following standard and conformity assessment systems.

- ANSI, EN, JIS

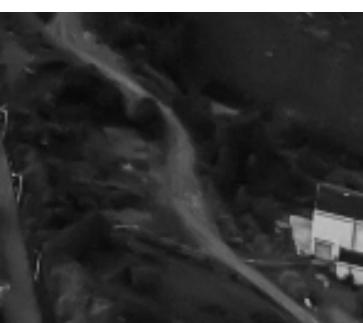

VALVE SIZING & SELECTION

Contact Clorius Controls for dimensioning of valve sizes - we will assist you in calculating size of control valves also in combination with electric or pneumatic actuators. (Kvs value, required nominal valve size, etc.)

CONTACT INFORMATION:
mail@cloriuscontrols.com

Contact information our sales team: please see www.broenclorius.com under "contacts"

FREQUENTLY ASKED QUESTIONS

Our Frequently Asked Questions attempts to provide answers to the most commonly asked questions relating to our products and services. If you don't find answers to your questions here, please get in touch with your nearest Clorius Controls representative.

How to find the correct size of valve and what actuator to choose?

In an attempt to simplify the process and avoid potential mistakes we advise our client to contact our sales team (see also www.broenclorius.com under contacts). Our sales team will assist you in getting the right combination of actuator and control valve.

What is the definition of k_{VS} value and how to calculate the flow?

The k_{VS} -value is identical to the IEC flow coefficient k_V and defined as the water flow rate in m^3/h through the fully open valve by a constant differential pressure, Δp_V , of 1 bar.

The K_{VS} value is a special case of the K_V value, which indicates the flow at a given valve position and a pressure differential of 1 bar.

The flow at a lower pressure loss can be calculated by rearranging the equation:

$$K_{VS} = Q / \sqrt{\Delta P}$$

where

K_{VS} : K_{VS} value [m^3/h]

Q: Flow [m^3/h]

ΔP : Pressure differential across a regulating valve [bar]

$$k_{VS} = \frac{Q(m^3/h)}{\sqrt{\Delta p(\text{bar})}}$$

$$\Delta p(\text{bar}) = \left(\frac{Q(m^3/h)}{k_{VS}} \right)^2$$

Should I use a strainer with my control valve?

It is recommended to use a strainer in front of the control valve if the liquid contains suspended particles.

What standards are used when manufacturing the valve?

All valves are manufactured under ISO 9001 certification and are pressure and leakage tested before shipment.

REDUCE UP TO 10% IN FUEL CONSUMPTION

Clorius Controls' low leakage control valve assures energy savings by reduction in fuel consumption, leading to reduced costs and downtime for shipowners.

BACKGROUND

In 2013 Clorius Controls successfully designed a robust low leakage valve in collaboration with MAN Diesel & Turbo, for a new internal cooling water system.

Today the low leakage control valve is used in the standard design of MAN Diesel & Turbo's two stroke engines, improving the performance of the engine cooling system.

The low leakage control valve is also installed on the world's largest container ships, the Triple E series.

THE CHALLENGE

Shipowners are currently faced with two main challenges:

- Fresh water generation when slow steaming

When a ship is slow steaming, a high leakage cooling valve causes the fresh water generator to stop producing water, leaving two options; either to buy fresh water from the nearest shore or start the preheater.

- Unwanted engine cooling when in harbour

When the ship is in harbour, energy is wasted for preheating purposes as a result of leaking cooling water. The cooling water passing through the engines causes unwanted cooling.

FEATURED TESTIMONIAL

“ Clorius Controls has been a trusted partner for many years, and their equipment has been included in the auxiliary systems for our two-stroke diesel engines during the last 30 years. Furthermore, their service and equipment have been an appreciated part in our systems, at our R&D center”.

*Ole Skeltved,
Head of Marine Installation Department
MAN Diesel & Turbo*

THE SOLUTION

By installing Clorius Controls' low leakage control valve, following savings can be achieved:

■ By not starting the preheater for fresh water generation:¹

Water consumption	= 7t /day
1 kg oil to produce	= 13 kg water
Oil consumption	= 538 kg/day
Savings in USD ²	~ 325\$/day

■ By not wasting energy on leaking cooling water:

Oil consumption can be reduced up to **10%** by implementing a low leakage control valve, compared to valves with leakage rate of 5%.³

Oil consumption	= 7t/day
Oil consumption saving	= 0.7 t/day
Savings in USD ²	~ 420\$/day

THE RECOMMENDATION

Shipowners should specify leakage class IV with max 0.01% leakage rate for both new builds and existing installations.

ROI for installing or replacing existing valves, with a Clorius Controls' low leakage control valve, is less than 1 month.

THE FACTS

LOCATION
COPENHAGEN, DENMARK

TECHNICAL DATA

Valve body:	Nodular cast iron
Trim:	Gun metal RG 5
Size & Pressure:	
DN 80-200	PN 16
DN 250-300	PN 10
Temperature range:	Max 150 °C
Flowrate :	80-1250m ³
Leakage Port AB-B:	<0,01% of KVS
Lead time:	4-6 weeks

European make

Valve supplied with electric or pneumatic actuation

¹ Example from a large container ship

² Bunkerindex-MDO 05.02.2015: 601 USD/t

³ Based on feedback from various shipowners.

OUR CLIENTS

We have had the good fortune of being involved with a large number of strong global companies. Our clients are our starting point. They drive everything we do and we work collaboratively with them to achieve results they can measure. Our size enables our specialists to work closely together to develop tailor-made solutions, that meet our clients' evolving needs.

Here are some clients we have recently added to our growing list of partnerships.

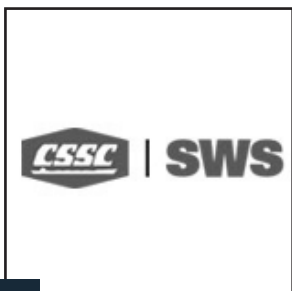
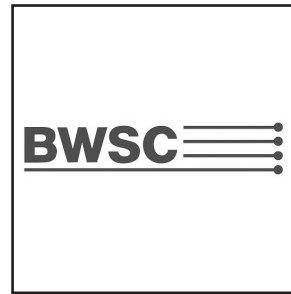
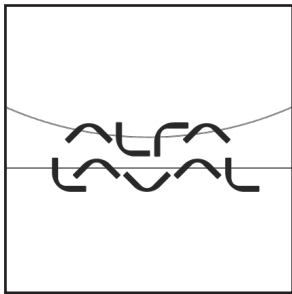

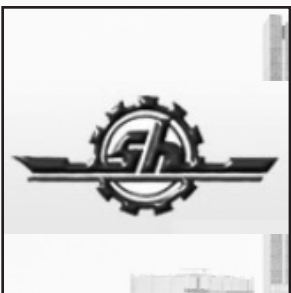

OVERVIEW OF CLORIUS VALVES

AVAILABLE STANDARDS FOR CONNECTIONS

Type	Material	Material	DN	INCH	Flange connection						Internal Connection Threads		
					EN 1092	ANSI 150	JIS 5K	JIS 10K	JIS 16K	DIN86021	ISO 7/1	NPT	
L1S	RG5	CuSn10-C	15/6 - 20	¾"								•	•
L1SB	RG5	CuSn10-C	15 - 32	½" - 1¼"						•		•	•
L1SBR	RG5	CuSn10-C	15 - 32	½" - 1¼"								•	•
L2S	RG5	CuSn10-C	40 - 50	1½" - 2"								•	
L2F	RG5	CuSn10-C	65 - 150	2½" - 6"						•			
L2SR	RG5	CuSn10-C	40	1½"								•	
L2SR	RG5	CuSn10-C	50	2"								•	•
L3S	RG5	CuSn10-C	15 - 50	½" - 2"								•	
L3F	RG5	CuSn10-C	65 - 100	2½" - 4"		•							
L3FA	RG5	CuSn10-C	80 - 300	3" - 12"						•			
L2FMT	RG5	CuSn10-C	65 - 800	2½" - 32"	•	•	•	•					
L3FMT	RG5	CuSn10-C	65 - 800	2½" - 32"	•	•	•	•					
H1F	GS-C25	GP240GH	15/4 - 50	2"	•	•	•	•	•				
H1FBN	GS-C25	GP240GH	15 - 80	½" - 3"	•	•	•	•	•				
H1FB	GS-C25	GP240GH	25 - 80	1" - 3"	•								
H1FBE - G1FBE	GS-C25	GP240GH	200 - 250	8" - 10"	•	•	•	•	•				
H2F	GS-C25	GP240GH	20 - 80	¾" - 3"	•	•	•	•	•				
H2F	GS-C25	GP240GH	100 - 150	4" - 6"	•	•							
H2FR	GS-C25	GP240GH	20 - 80	¾" - 3"	•	•	•	•	•				
H2FR	GS-C25	GP240GH	100 - 150	4" - 6"	•								
H3F	GS-C25	GP240GH	20 - 65	¾" - 2½"	•	•	•	•	•				
H3F	GS-C25	GP240GH	100 - 150	4" - 6"	•	•							
G1F	GGG40	EN-GJS-400-15	15/4 - 50	2"	•	•	•	•	•				
G1FB	GGG40	EN-GJS-400-15	25 - 65	1" - 2½"	•								
G1FBN	GGG40	EN-GJS-400-15	15 - 80	½" - 2½"	•	•	•	•	•				
G2F	GGG40	EN-GJS-400-15	20 - 80	¾" - 3"	•	•	•	•	•				
G2F	GGG40	EN-GJS-400-15	100 - 150	4" - 6"	•	•							
G2FR	GGG40	EN-GJS-400-15	20 - 80	¾" - 2½"	•	•	•	•	•				
G2FR	GGG40	EN-GJS-400-15	100 - 150	4" - 6"	•	•							
G3F	GGG40	EN-GJS-400-15	20 - 65	1" - 2½"	•	•	•	•	•				
G3F	GGG40	EN-GJS-400-15	80 - 150	2½" - 6"	•	•							
G3F-I with soft seats	GGG40	EN-GJS-400-15	80 - 300	6" - 10"	•								
G3FA-I with soft	GGG40	EN-GJS-400-15	80 - 300	6" - 10"	•								

Type	Material	Material	DN	INCH	Flange connection					
					EN 1092	ANSI 150	JIS 5K	JIS 10K	JIS 16K	Grooved
G3FA	GGG40	EN-GJS-400-15	80 - 300	3" - 12"	•	•		•		
G3FA-I	GGG40	EN-GJS-400-15	80 - 300	3" - 12"	•	•		•		
G2FM-T	GGG40	EN-GJS-400-15	65 - 800	2½" - 32"	•	•	•	•		
G3FM-T	GGG40	EN-GJS-400-15	65 - 800	2½" - 32"	•	•	•	•		
G3CM-TR/L	GGG40	EN-GJS-400-15	100 - 300	4" - 6"						•
M1F	GG25	EN-GJS-400-15	15/4 - 50	2"	•	•	•	•	•	
M1FBN	GG25	EN-GJS-400-15	15 - 80	½" - 3"	•	•	•	•	•	
M2F	GG25	EN-GJS-400-15	20 - 80	¾" - 3"	•	•	•	•	•	
M2F	GG25	EN-GJS-400-15	100 - 150	4" - 6"	•					
M2FR	GG25	EN-GJS-400-15	20 - 80	¾" - 3"	•	•	•	•	•	
M2FR	GG25	EN-GJS-400-15	80 - 150	3" - 6"	•	•				
M3F	GG25	EN-GJS-400-15	20 - 65	¾" - 2½"	•	•	•	•	•	
M3F	GG25	EN-GJS-400-15	80 - 150	3" - 6"	•	•				
M3FA	GG25	EN-GJS-400-15	80 - 150	3" - 6"	•	•		•		
M3FA-I	GG25	EN-GJS-400-15	80 - 300	3" - 6"	•	•		•		
S2FM-T	AISI316	AISI316	65 - 800	2½" - 6"	•	•	•	•		
S3FM-T	AISI316	AISI316	65 - 800	2½" - 6"	•	•	•	•		
TREX	STEEL	STEEL ST 235	15 - 40	½" 1½"						•
TREX	ALU	ALUMINIUM AW 6082/T6	15 - 40	½" 1½"						•

OVERVIEW OF CLORIUS ACTUATORS

ELECTRIC AND PNEUMATIC ACTUATORS FOR ROTARY VALVES

Type L3FMT-/L/R, G3FMT-/L/R, S3FMT-L/R VALVES

DN	KVS mixing	KVS Diverting	Required torque, Nm (P1≤5bar)	CAR	ADHW	AS & ASHW	AD	Required torque, Nm (P1≤10bar)	CAR	ADHW	AS & ASHW	AD
65	95	120	28	009	65	65	65	35	009	100	65	65
80	122	154	30	009	100	65	65	40	009	100	100	65
100	175	220	55	009	100	100	65	70	009	100	100	100
125	245	330	90	019	100	100	100	120	019	100	125	100
150	395	425	120	019	125	125	100	160	028	125	125	100
200	800	1100	185	028	125	125	100	250	060	140	140	125
250	1500	2100	285	060	140	140	125	395	060	160	160	125
300	2000	2650	400	060	160	160	125	550	100	210	160	140
350	2530	3380	640	100	210	210	140	980	200	250	210	160
400	3050	3950	895	100	210	210	160	1370	200	250	250	210
450	3680	4480	1050	200	250	210	160	1550	200	250	250	210
500 550	4150	5250	1300	200	250	250	210	1920	250	300	300	250
600	4150	6050	1850	200	300	250	210	2950	300	300	300	250
800	6200	8000	2600	-	300	-	-	4000	-	-	-	-

ELECTRIC AND PNEUMATIC ACTUATORS FOR ROTARY VALVES

Type L3FMT-M, G3FMT-T, S3FMT-T VALVES

DN	KVS mixing	KVS Diverting	Required torque, Nm (P1≤5bar)	CAR	ADHW	AS & ASHW	AD	Required torque, Nm (P1≤10bar)	CAR	ADHW	AS & ASHW	AD
65	110	127	42	009	65	100	65	50	009	100	100	65
80	148	162	45	009	100	100	65	55	009	100	100	65
100	220	248	80	009	100	100	100	97	019	125	100	100
125	369	437	125	019	125	125	100	153	019	125	125	100
150	510	600	179	019	125	125	100	215	028	140	140	100
200	807	1100	285	060	140	140	125	345	060	160	160	125
250	1500	2100	465	060	160	160	125	585	060	210	210	140
300	2000	2650	650	100	210	210	160	795	100	250	210	160
350	2505	3515	980	100	250	210	160	1350	200	250	250	210
450	3400	4300	1550	200	300	250	210	2100	250	300	300	210

DN	KVS mixing	KVS Diverting	Required torque, Nm (P1≤16bar)	CAR	ADHW	AS & ASHW	AD	Required torque, Nm (P1≤25bar)	CAR	ADHW	AS & ASHW	AD
65	95	120	46	009	100	100	65	60	009	100	100	65
80	122	154	55	009	100	100	65	65	009	100	100	65
100	175	220	90	019	100	100	100	120	019	125	125	100
125	245	330	150	028	125	125	100	200	028	125	125	100
150	395	425	200	028	125	125	100					
200	800	1100	330	060	160	140	125					
250	1500	2100	525	060	210	160	140					
300	2000	2650	730	100	210	210	160					
350	2530	3380										
400	3050	3950										
450	3680	4480										
500	4150	5250										
550	4150	6050										
600	4150	6050										
800	6200	8000	5800		-	-	-	8420	-	-	-	-

DN	KVS mixing	KVS Diverting	Required torque, Nm (P1≤16bar)	CAR	ADHW	AS & ASHW	AD	Required torque, Nm (P1≤25bar)	CAR	ADHW	AS & ASHW	AD
65	110	127	60	009	100	100	65	72	009	100	100	100
80	148	162	67	009	100	100	100	85	009	100	100	100
100	220	248	115	019	100	125	100	145	019	125	125	100
125	369	437	197	028	125	125	100	245	028	125	140	125
150	510	600	259	028	160	140	125					
200	807	1100	435	060	210	160	125					
250	1500	2100	695	100	210	210	160					
300	2000	2650	975	100	250	210	160					
350	2505	3515										
450	3400	4300										

MINIMAL LEAKAGE
MAXIMAL PERFORMANCE

Clorius Controls, linear and rotary control valves assure energy savings by reduction in oil consumption, leading to reduced cost and downtime for ships.



CONTROL VALVES

OUR CONTROL VALVES PROGRAM INCLUDES:

MATERIAL

GUN METAL
BRONZE
CAST IRON
CAST STEEL
NODULAR CAST STEEL
STAINLESS STEEL

AVAILABLE SIZES

15/6mm - 600 mm
50mm - 400 mm
15/4mm - 150 mm
15/4mm - 800 mm
65mm - 600 mm
15mm - 40mm

PN

PN10//PN16
PN10
PN16//PN25//PN40
PN10//PN16//PN25
PN10//PN16
PN16

GENERAL STANDARDS

ANSI//JIS//EN
ANSI//JIS//EN
ANSI//JIS//EN
ANSI//JIS//EN
ANSI//JIS//EN

2-way Control Valve type L1S

Gun Metal, PN 16, DN 15/6 – 20 mm. Single Seated

0-2.2.02-L

Page 1 of 2

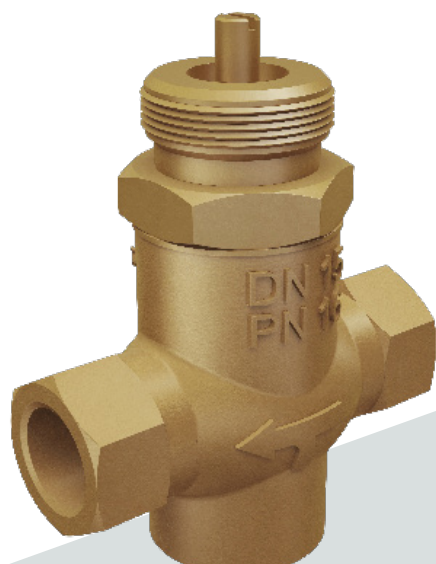

APPLICATIONS

Control valves type L1S are designed for regulating low, medium and high pressure hot water, steam and lubricating oils with thermostats, pneumatic or electric actuators. The valves are installed combined with temperature or pressure differential regulators in control systems for heating of domestic premises, district heating, industrial processes or marine installations. They can also be used in cooling applications when used with an electric actuator.

DESIGN

The valve components - spindle, seat and cone - are made of stainless steel. The valve body is made of gun metal RG 5. The thread for the actuator connection is G1B ISO 228. The valve is single seated. The leakage rate is less than 0.05% of the full flow (according to VDI/VDE 2174).

FUNCTION

Without the actuator being connected, the valve is held in open position by means of a spring. With pressure on the spindle the valve will close. In connection with thermostats, pneumatic or electric actuators, the valve will close at rising temperatures. For cooling circuits the valve can be used in conjunction with a reverse acting electric actuator. Alternatively a reverse acting valve can be used with our self-acting thermostats. The quadratic characteristic will not cease, until the flow has dropped below 4% of the full flow.

TECHNICAL DATA

Materials:

- Valve body	Gun metal RG 5
- Components	Stainless steel
- Gasket	Reinz AFM34
Nominal pressure	PN 16
Seating	Single seated
Flow characteristic	Quadratic
Leakage rate	$\leq 0.05\%$ of Kvs
Regulating capability	Kvs/Kvr > 25
Internal connection threads	ISO 7/1
Single seated and tight closing	

FEATURES

- Simple design secures reliable controls and reduces costly downtime
- Location of the pack box in the actuator makes the valve service friendly
- Reliable and secure due to internal parts of stainless steel
- Low leakage rate reduces the risk of overheating

PRESSURE/TEMPERATURE DIAGRAM

According to DIN 2401

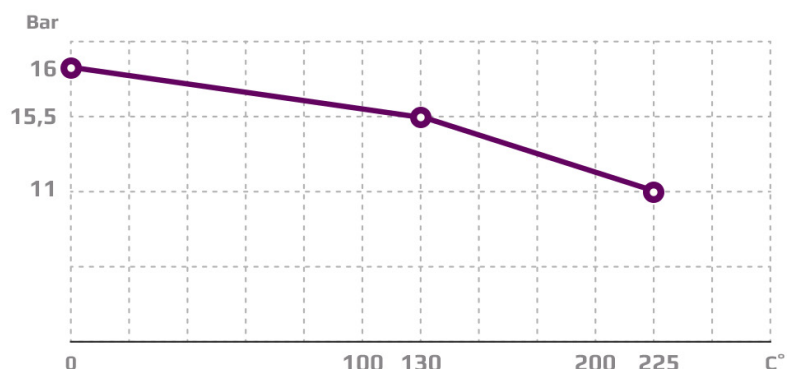

Subject to change without notice.

MOUNTING

The valve can be installed with vertical as well as horizontal spindles. For valve temperatures of max. 170 °C, the thermostat/ actuator can be fitted below or above the valve. For valve mounted with thermostats in media temperatures above 170 °C, a cooling unit has to be applied with connection downwards (please refer to data sheet for thermostat accessories). For electric actuators a high temperature adaptor must be used (please refer to datasheets for the electric actuators).

DIMENSION SKETCH

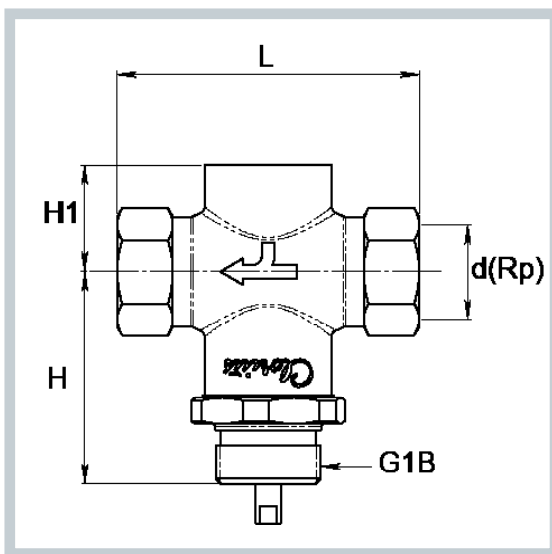

Type	L (mm)	H (mm)	H1 (mm)	d
15/6 L15	85	65	20	Rp ½
15/9 L15	85	65	20	Rp ½
15/12 L15	85	65	20	Rp ½
15 L15	85	65	26	Rp ½
20 L15	95	67	32	Rp ¾

SPECIFICATIONS

Type	Connection threads	DN (mm)	Opening (mm)	k_{vs} -value m^3/h	Lifting height (mm)	Weight (kg)
15/6 L15	Rp ½	15	6	0.45	6	0.7
15/9 L15	Rp ½	15	9	0.95	6	0.7
15/12 L15	Rp ½	15	12	1.7	6	0.7
15 L15	Rp ½	15	15	2.75	6	0.7
20 L15	Rp ¾	20	20	5.00	7	0.8

2-way Control Valve type L1SB

Gun Metal, PN 16, DN 15 - 32 mm

0-2.2.04-I

Page 1 of 2

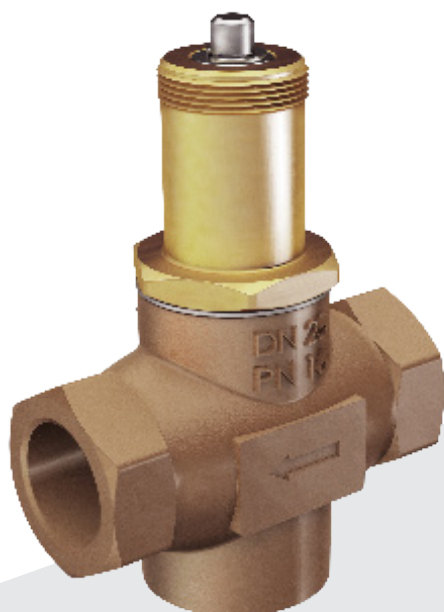

APPLICATIONS

Balanced control valves type L1SB are designed for regulation of hot water, steam and lubricating liquids. The valves are installed combined with our self-acting thermostats, pressure differential regulators, pneumatic or electric valve actuators for regulation in central heating plants, industrial plants, industrial processes or marine installations. Balanced valves are used in installations where the system pressure necessitates a closing force greater than available in the actuator programme for a standard single seated valve, and where the leakage rate for a double-seated valve is unacceptable.

DESIGN

The valve components - spindle, seats and cone - are made of stainless steel. The valve body is made of gun metal RG 5 (red brass). The thread for the actuator connection is G1B ISO 228. The valve is single seated, balanced. The leakage rate is less than 0.05% of the full flow (according to VDI/VDE 2174).

FUNCTION

Without the actuator being connected, the valve is held in open position by means of a spring. With pressure on the spindle the valve will close. In connection with our thermostats the valves will close at rising temperatures. In connection with our pneumatic or electric valve actuators the valves will either close or open depending on the application. The quadratic characteristic will not cease, until the flow has dropped below 4% of the full flow.

TECHNICAL DATA

Materials:

- Valve body	Gun metal RG 5
- Components	Stainless steel
- O-ring	FPM, 75 SHOREA
- Gasket	Reinz-AFM34
Nominal pressure	PN 16
Seating	Single seated
Flow characteristic	Quadratic
Leakage rate	$\leq 0.05\%$ of Kvs
Regulating capability	Kvs/Kvr > 25
Internal connection threads	ISO 7/1
Pressure balanced control valve	

FEATURES

- Simple design secures reliable controls and reduces costly downtime
- Location of the pack box in the actuator makes the valve service friendly
- Reliable and secure due to internal parts of stainless steel
- Low leakage rate reduces the risk of overheating

PRESSURE/TEMPERATURE DIAGRAM

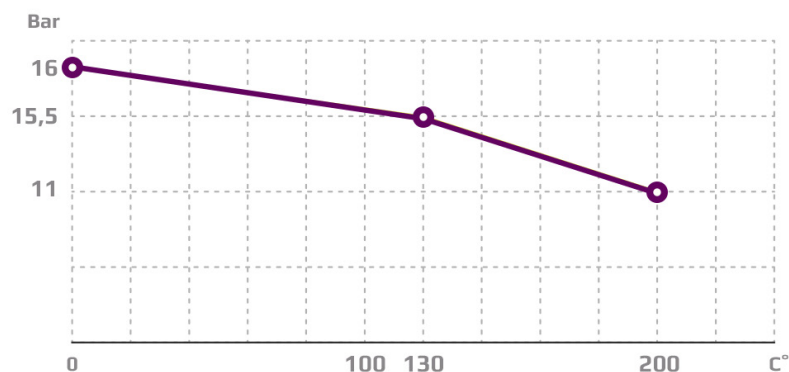

Subject to change without notice.

MOUNTING

The valve can be installed with vertical as well as horizontal spindles. For valve temperatures of max. 170 °C, the thermostat/ actuator can be fitted below or above the valve. For valve mounted with thermostats in media temperatures above 170 °C, a cooling unit has to be applied with connection downwards (please refer to data sheet for thermostat accessories). For electric actuators a high temperature adaptor must be used (please refer to datasheets for the electric actuators).

DIMENSION SKETCH

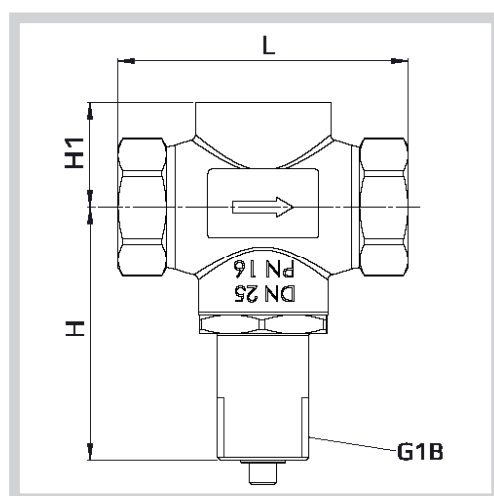

Type	L (mm)	H (mm)	H1 (mm)
15 L15B	85	86	30
20 L15B	95	94	35
25 L15B	105	92	40
32 L15B	138	94	54

SPECIFICATIONS

Type	Connection threads	DN (mm)	Opening (mm)	k_{vs} -value m^3/h	Lifting height (mm)	Weight (kg)
15 L15B	Rp 1/2	15	15	2.75	6	1.0
20 L15B	Rp 3/4	20	20	5	6.5	1.3
25 L15B	Rp 1	25	25	7.5	7	1.6
32 L15B	Rp 1 1/4	32	32	12.5	8	2.9



Balanced 2-way Control Valve type L1SBR

Gun Metal, PN 16, DN 15 – 32 mm, Reverse acting

0-2.2.04.01-D

Page 1 of 2

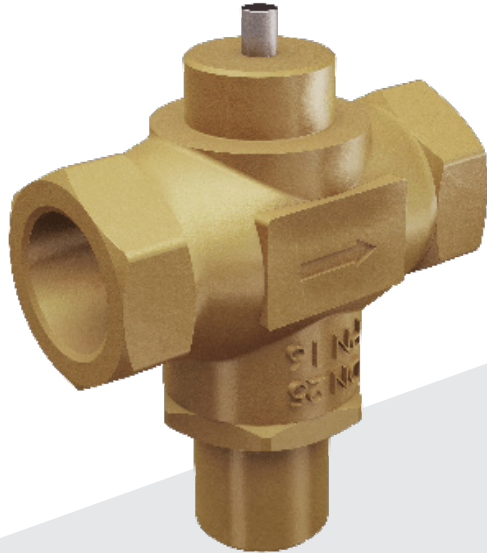

TECHNICAL DATA

Materials:	
- Valve body	Gun metal RG 5
- Components	Stainless steel
- O-ring	FPM, 75 SHOREA
- Gasket	Reinz-AFM34
Nominal pressure	PN 16
Seating	Single seated
Flow characteristic	Quadratic
Leakage rate	$\leq 0.05\%$ of Kvs
Regulating capability	Kvs/Kvr > 25
Internal connection threads	ISO 7/1

APPLICATIONS

Balanced control valves type L1SBR are mainly designed for regulation of cooling water and lubricating liquids. Balanced valves are used in installations where the system pressure necessitates a closing force greater than available in the actuator programme for a standard single seated valve, and where the leakage rate for a double-seated valve is unacceptable. The valves are installed combined with our self-acting thermostats, pressure differential regulators or electric actuators for regulation in industrial plants, industrial processes or marine installations - especially in control systems for cooling.

DESIGN

The valve components - spindle, seats and cone - are made of stainless steel. The valve body is made of gun metal RG 5. The thread for the actuator connection is G1B ISO 228. The valve is single seated, balanced. The leakage rate is less than 0.05% of the full flow (according to VDI/VDE 2174).

FUNCTION

Without the actuator being connected, the valve is held in closed position by means of a spring. With pressure on the spindle the valve opens. In connection with our thermostats the valves will open at rising temperatures. In connection with our electric actuators the valves will either close or open depending on the application. The quadratic characteristic will not cease, until the flow has dropped below 4% of the full flow.

FEATURES

- Simple design secures reliable controls and reduces costly downtime
- Location of the pack box in the actuator makes the valve service friendly
- Reliable and secure due to internal parts of stainless steel
- Low leakage rate reduces the risk of overheating

PRESSURE/TEMPERATURE DIAGRAM

According to DIN 2401

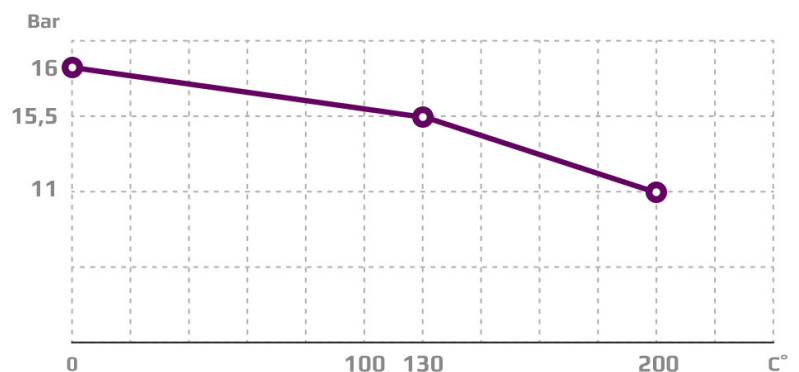

Subject to change without notice.

MOUNTING

The valve can be installed with vertical as well as horizontal spindles. For valve temperatures of max. 170 °C, the thermostat/ actuator can be fitted below or above the valve. For valve mounted with thermostats in media temperatures above 170 °C, a cooling unit has to be applied with connection downwards (please refer to data sheet for thermostat accessories). For electric actuators a high temperature adaptor must be used (please refer to data sheets for the electric actuators).

DIMENSION SKETCH

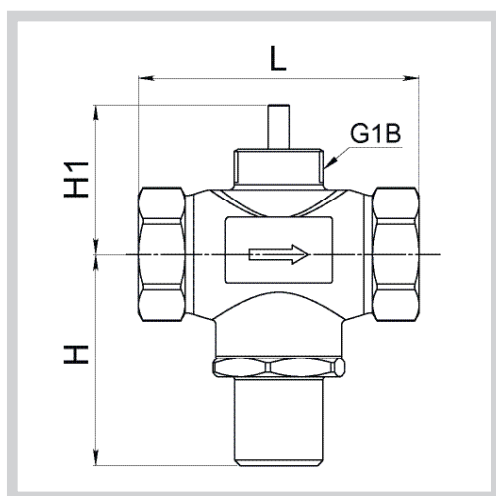

Type	L (mm)	H (mm)	H1 (mm)
15 L1SBR	85	71	40
20 L1SBR	95	79	46
25 L1SBR	105	79	50
32 L1SBR	138	81	64

SPECIFICATIONS

Type	Connection threads	DN (mm)	Opening (mm)	k_{vs} -value m^3/h	Lifting height (mm)	Weight (kg)
15 L1SBR	Rp ½	15	15	2.75	6	1.0
20 L1SBR	Rp ¾	20	20	5	6.5	1.3
25 L1SBR	Rp 1	25	25	7.5	7	1.6
32 L1SBR	Rp 1 ¼	32	32	12.5	8	2.9



2-way Control Valve type L2S

Gun Metal, PN 16, DN 40 – 50 mm

0-2.2.05-K

Page 1 of 2



TECHNICAL DATA

Materials:

- Valve body	Gun metal RG 5
- Components	Gun metal RG 5
- Stem	Brass
- Gasket	Reinz-AFM34
Nominal pressure	PN 16
Seating	Double seated
Flow characteristic	Linear
Leakage rate	$\leq 0.5\%$ of Kvs
Regulating capability	Kvs/Kvr > 25
Internal connection threads	ISO 7/1

APPLICATIONS

Control valves type L2S are designed for regulation of hot water and lubricating oils. The valves are installed combined with one of our self-acting thermostats, pressure differential regulators or electric valve actuators for regulation in central heating plants, industrial plants, industrial processes or marine installations.

DESIGN

The valve body, seats and cone are made of gun metal RG 5. The stem is made of brass. The thread for the actuator connection is G1B ISO 228. The valves are double seated. The leakage rate is less than 0.5% of the full flow (according to VDI/VDE 2174).

FUNCTION

Without the actuator being connected, the valve is held in open position by means of a spring. With pressure on the spindle the valve will close. In connection with our thermostats or electric actuators, the valves will close at rising temperatures. For cooling circuits the valve can be used in conjunction with a reverse acting electric actuator. Alternatively a reverse acting valve can be used with our self-acting thermostats. The linear characteristic will not cease, until the flow has dropped below 4% of the full flow.

FEATURES

- Simple design secures reliable controls and reduces costly downtime
- Location of the pack box in the actuator makes the valve service friendly

PRESSURE/TEMPERATURE DIAGRAM

According to DIN 2401

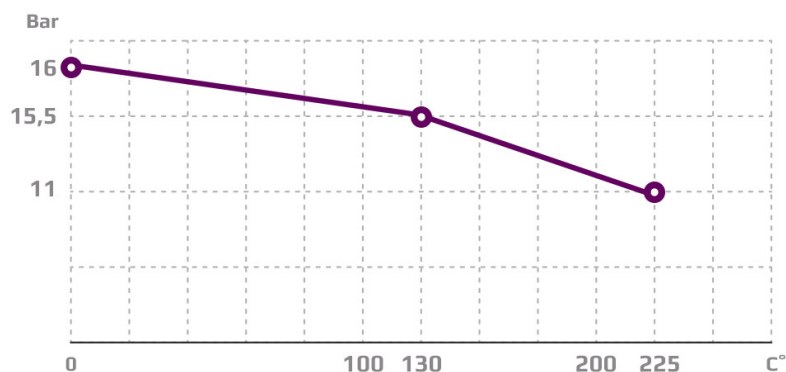

Subject to change without notice.



MOUNTING

The valve can be installed with vertical as well as horizontal spindles. For valve temperatures of max. 170 °C, the thermostat/ actuator can be fitted below or above the valve. For valve mounted with thermostats in media temperatures above 170 °C, a cooling unit has to be applied with connection downwards (please refer to data sheet for thermostat accessories). For electric actuators a high temperature adaptor must be used (please refer to data sheets for the electric actuators).

DIMENSION SKETCH

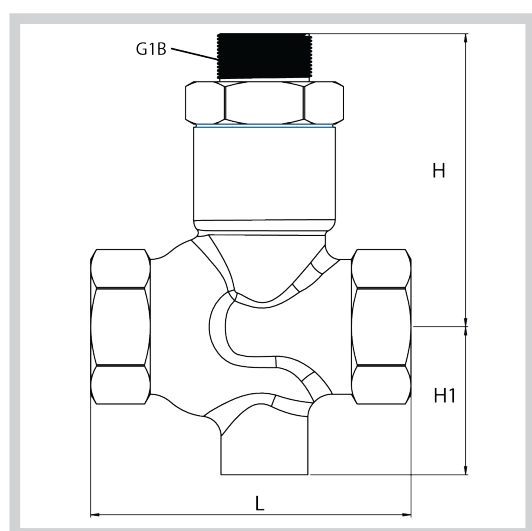

Type	L (mm)	H (mm)	H1 (mm)
40 L2S	129	118	68
50 L2S	153	122	71

SPECIFICATIONS

Type	Connection threads	DN (mm)	Opening (mm)	k_{vs} -value m^3/h	Lifting height (mm)	Weight (kg)
40 L2S	Rp 1/2	40	40	20	8	2.9
50 L2S	Rp 2	50	50	30	9	3.8

2-way Control Valve type L2F

Gun metal, PN 10, DN 65 – 150 mm

0-2.2.05.01-B

Page 1 of 2



APPLICATIONS

Control valves type L2F are designed for regulating hot water - and cold and hot sea water. The valves are used in connection with one of our temperature regulators in control systems for industrial processes or marine installations.

DESIGN

The valve components - valve body, seats, cone and spindle - are made of sea water resistant materials with connection flanges drilled according to DIN 86021. The connection thread for the actuator is G1B.

FUNCTION

Without the actuator being connected, the valve is held in open position by means of a spring. With pressure on the spindle the valve will close. In connection with our thermostats or electronic actuators, the valves will close at rising temperatures. The linear characteristic will not cease, until the flow has dropped below 4% of the full flow.

TECHNICAL DATA

Materials:

- Valve body	CuSn10
- Seats and cone	CUAI10Fe5Ni5
- Spindle	W.no. 1.4436
- O-ring	90 NBR
- Gasket	Reinz-AFM34
Nominal pressure	PN 10
Seating	2 balanced seats
Flow characteristic	Almost linear
Leakage rate	≤ 0.5% of Kvs
Regulating capability	Kvs/Kvr > 25
Flanges drilled according to	DIN 86021 or ANSI Class 150

FEATURES

- Sea water resistant
- Simple design secures reliable controls and reduces costly downtime
- Location of the pack box in the actuator makes the valve service friendly
- Reliable and secure due to internal parts of stainless steel

PRESSURE/TEMPERATURE DIAGRAM

According to DIN 2401

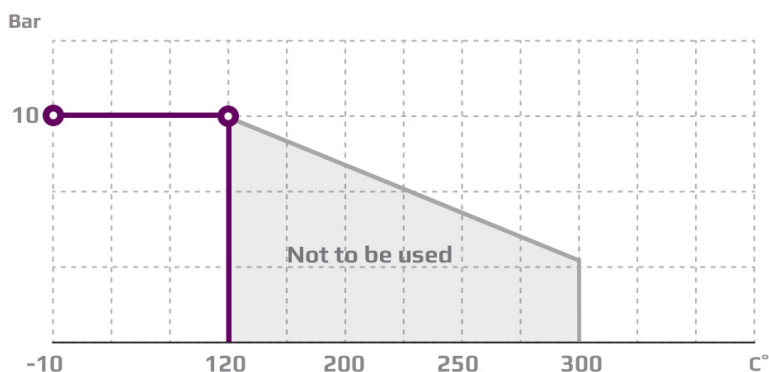

Subject to change without notice.

PORT NUMBERING

The ports of valves type L2F are marked with the figures 1 and 2. The letters in parentheses refer to the corresponding internationally adapted designations.



MOUNTING

The valves can be installed with vertical as well as horizontal spindles. The valves must be mounted in a way that the valve actuator will be exposed to a minimum of moisture and unnecessary vibrations.

DIMENSION SKETCH

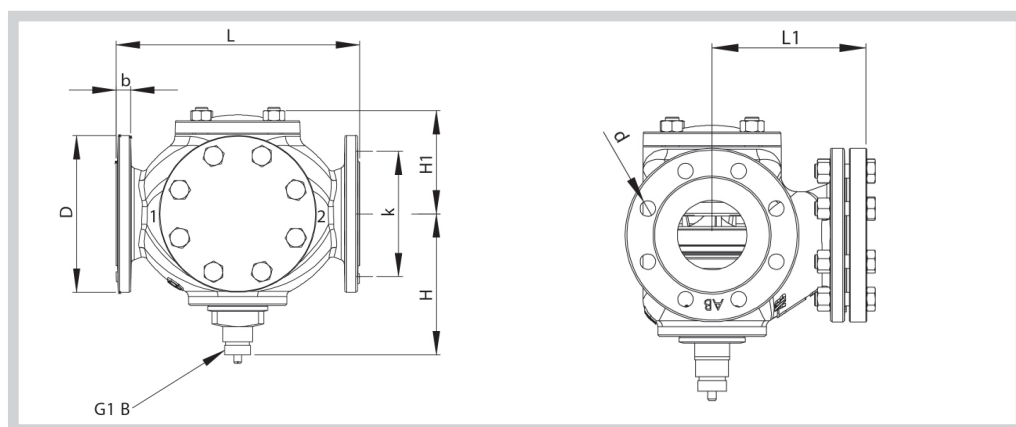

Type	L (mm)	L1 (mm)	H (mm)	H1 (mm)	D (dia.) (mm)	b (mm)	k (dia.) (mm)	d mm dia. (number)
65 L2F	240	150	175	120	185	20	145	18x(4)
80 L2F	260	160	185	125	200	22	160	18x(8)
100 L2F	350	205	195	145	220	22	180	18x(8)
125 L2F	400	275	245	180	250	24	210	18x(8)
150 L2F	480	305	280	189	285	24	240	22x(8)

SPECIFICATIONS

Type	Flange connection DN in mm	Opening (mm)	k_{vs} -value m^3/h	Lifting height (mm)	Weight (kg)
65 L2F	65	65	50	10.50	27
80 L2F	80	80	80	11	36
100 L2F	100	100	125	13	62
125 L2F	125	125	215	18	102
150 L2F	150	150	310	21	145

2-way Control Valve type L2FM-T

Gun metal, PN 16, DN 65 – 125 / PN 10, DN 150 – 300 / PN 6, DN 350 – 800 mm

0-2.2.05.03-C

Page 1 of 4

APPLICATIONS

Control valve type L2FM-T is a three-way control valve with blocked port making a two-way control valve. The slide for quarter turn operation designed for regulating of sea water. The valves are designed for use in conjunction with industrial processes, marine installations with large water quantities. The valves are designed for use in conjunction with valve motor type CAR-H with handle for manual operation or for use in conjunction with a pneumatic actuator.

DESIGN

The valve body is made of gun metal and the valve slide is made of alu bronze. The valve flanges are drilled according to EN 1092-2 or ANSI Class 150.

FUNCTION

The slide is firmly connected with the motor spindle. When the slide is in the one extreme position by turning the spindle, flow from A to AB is kept fully open. In the other extreme position the valve is fully closed. In the intermediate positions the opening degrees change proportionally. The valve has a small tolerance between body and slide. To minimize the leakage an O-ring is mounted in a groove on the slide.

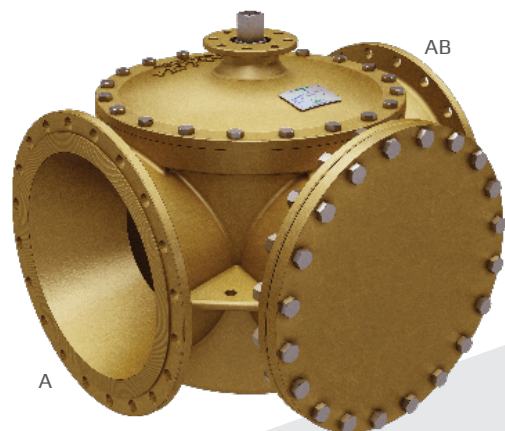

TECHNICAL DATA

Materials:

- Valve body	CuSn10
- Slide	CuAl10Fe5Ni5
- O-ring	NBR 70A
- U-ring	PTFE
- Gasket	AF 1000

- Nominal pressure
DN 65-300 L3FM-T

PN 10, max. 100°C
(option 120°C)

DN 350-800 L3FM-T

PN 6, max. 100°C
(option 120°C)

Flow characteristic

Almost linear

Leakage rate

≤ 0.5% of KV100

Regulating capability

Kvs/Kvr > 25

Flanges

EN 1092-2

Counter flanges

ANSI Class 150

(suggested)

DIN 2631 – PN 6

DIN 2632 – PN 10

DIN2633 – PN 16

Max. pressure Δp_L , against which the control can close:

- DN 65-125 L3FM-T	16 bar
- DN 150-300 L3FM-T	10 bar
- DN 350-800 L3FM-T	6 bar

Slide in CuAl10Fe5Ni5

FEATURES

- Sea water resistant
- Simple design secures reliable controls and reduces costly downtime
- Low leakage rate secures energy savings
- Flexible choice of port placements

PRESSURE/TEMPERATURE DIAGRAM

According to DIN 2401

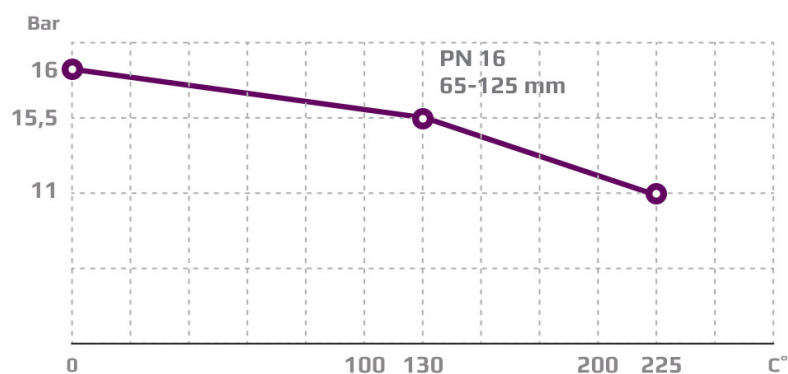

Subject to change without notice.

PRESSURE/TEMPERATURE DIAGRAM

According to DIN 2401

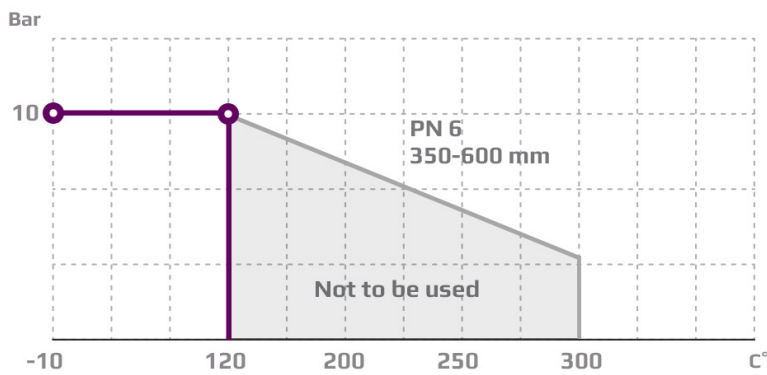
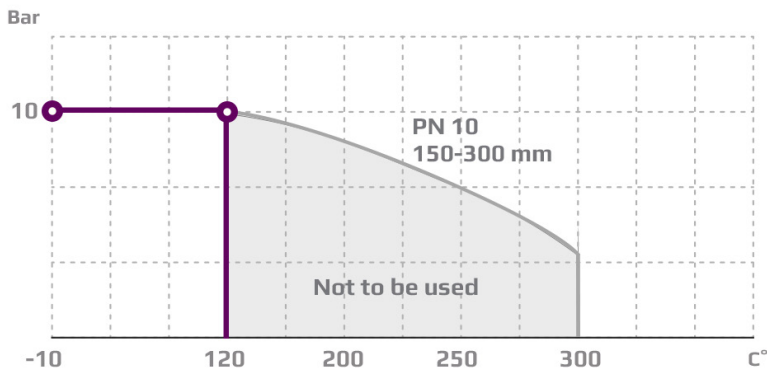

PORT NUMBERING

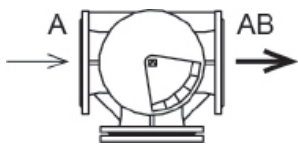

MOUNTING

The valve connections are marked A and AB. Check slide position before installation in the pipe. The slide position is marked on the top of the shaft. The valves can be installed with vertical as well as horizontal spindles. The valves must be mounted in a way that the valve actuator will be exposed to a minimum of moisture and unnecessary vibrations.

2-way Control Valve type L2FM-T

Gun metal, PN 16, DN 65 – 125 / PN 10, DN 150 – 300 / PN 6, DN 350 – 800 mm

DIMENSION SKETCH

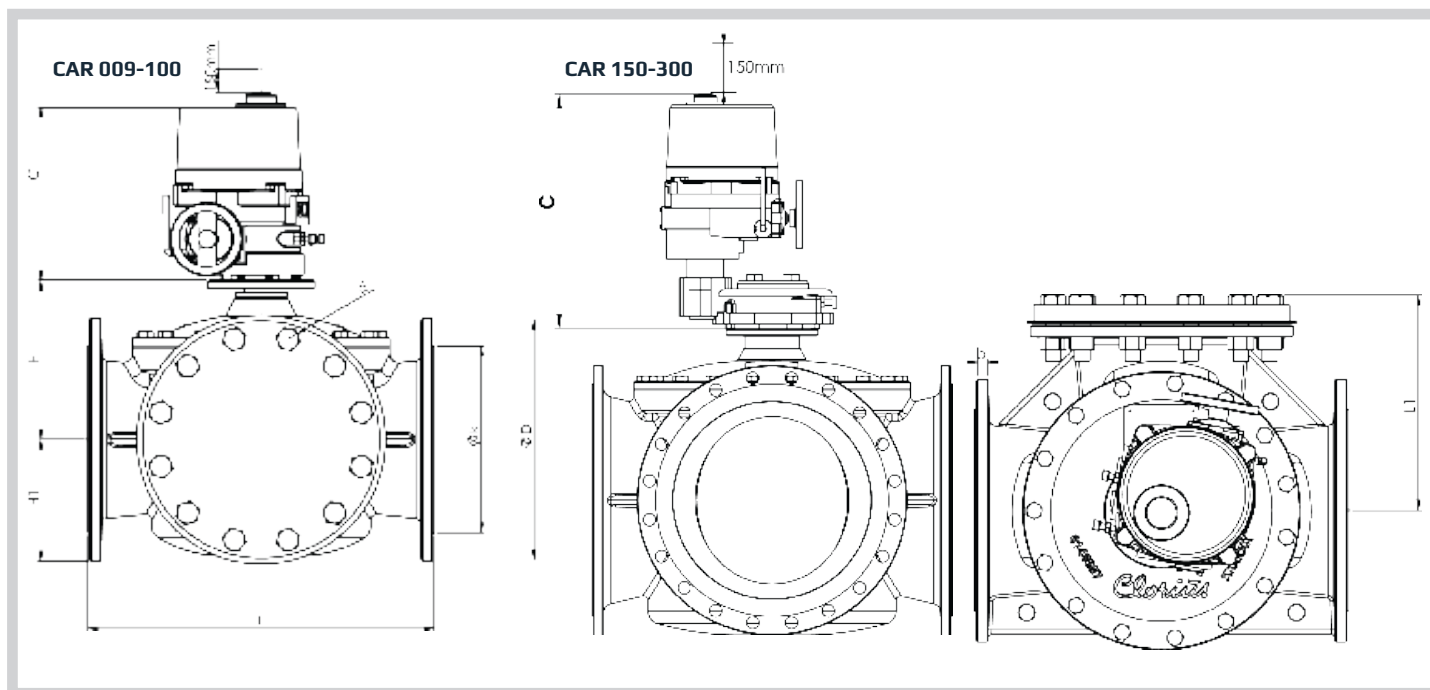

Type	EN 1092-2						ANSI Class 150			JIS B 2210 5K			JIS B 2210 10K					
	L (mm)	L1 (mm)	H (mm)	H1 (mm)	b (mm)	C (mm)	D (dia.)	k	d mm dia.	D (dia.)	k (dia.)	d mm dia.	D (dia.)	k (dia.)	d mm dia.	D (dia.)	k (dia.)	d mm dia.
65 L2FM-T	292	175	135	90	20	273	185	145	19x(8)	180	140	19x(4)	165	130	15x(4)	175	140	19x(4)
80 L2FM-T	292	175	140	94	20	273	200	160	19x(8)	190	152	19x(4)	180	145	19x(4)	185	150	19x(8)
100 L2FM-T	350	205	158	112	17	273	220	180	19x(8)	230	190,9	19x(8)	200	165	19x(8)	210	175	19x(8)
125 L2FM-T	400	231	179	123	17	273	250	210	19x(8)	255	216	19x(8)	235	200	19x(8)	250	210	23x(8)
150 L2FM-T	438	249	196	139	20	276	285	240	23x(8)	280	241	22x(8)	265	230	19x(8)	280	240	23x(8)
200 L2FM-T	530	301	236	175	21	361	340	295	23x(12)	343	299	23x(8)	320	280	23x(8)	320	290	23x(12)
250 L2FM-T	592	333	273	205	23	361	395	350	23x(12)	407	362	26x(12)	385	345	23x(12)	400	355	25x(12)
300 L2FM-T	649	365	305	230	25.5	361	455	400	23x(12)	483	432	26x(12)	430	390	23x(12)	445	400	25x(16)
350 L2FM-T	717	395	337	255	25.5	361	490	445	23x(12)	534	477	29x(12)	480	435	25x(12)	490	445	25x(16)
400 L2FM-T	770	421	375	285	26	361	540	495	23x(16)	597	540	29x(16)	540	495	25x(16)	560	510	27x(16)
450 L2FM-T	820	446	391	310	26.5	556	595	550	23x(16)	635	578	32x(16)	605	555	25x(16)	620	565	27x(20)
500 L2FM-T	900	492	425	340	27.5	556	645	600	23x(20)	699	635	32x(20)	655	605	25x(20)	675	620	27x(20)
550 L2FM-T	900	492	425	373	27.5	556	-	-	-	-	-	-	720	665	27x(20)	745	680	33x(20)
600 L2FM-T	1000	546	470	393	31.0	556	755	705	28x(20)	813	750	35x(20)	770	715	25x(20)	795	730	33x(24)
700 L2FM-T	1106	649	519	462	34.0	556	860	810	28x(24)	-	-	-	875	820	27x(24)	905	840	33x(24)

Subject to change without notice.

SPECIFICATIONS

Type	Flange connection	k_{vs} -value m ³ /h	Torque Nm	Weight kg
65 L2FM-T	65	120	46	37
80 L2FM-T	80	154	55	41
100 L2FM-T	100	220	90	56
125 L2FM-T	125	330	150	73
150 L2FM-T	150	425	160	84
200 L2FM-T	200	1100	250	153
250 L2FM-T	250	2100	395	215
300 L2FM-T	300	2650	550	277
350 L2FM-T	350	3380	640	340
400 L2FM-T	400	3950	895	459
450 L2FM-T	450	4480	1050	579
500 L2FM-T	500	5250	1300	744
550 L2FM-T	550	5250	1300	950
600 L2FM-T	600	6050	1850	1090
700 L2FM-T	700	7000	TBC	TBC
800 L2FM-T	800	8000	2600	2100

*Torque calculated at max inlet P for:

DN 65 - 125 = 16 Bar

DN 150-300 = 10 Bar

DN 350-800 = 5 Bar



2-way Control Valve type L2SR

Gun metal, PN 16, DN 40 – 50 mm, 2 seats, Reverse acting

0-2.2.06-L



APPLICATIONS

Valves type L2SR are mainly intended for control of cooling water, sea water and lubricating liquids. The valves are used in conjunction with temperature- or pressure differential regulators in industrial processes or marine installations - especially in control systems for cooling. As the reverse acting valves are held in closed position by means of a built-in spring, the max. differential pressure, Δp_L , against which a valve can close depends on the spring and when opening the valve, the actuator has to overcome the spring force.

DESIGN

The valve body, seats and cone – are made of gun metal RG 5 and the stem of stainless steel – the valve body with threaded ends according to ISO 7-1. The thread for the actuator connection is G1B. The valves are double-seated. The leakage rate is less than 0.5% of the full flow (according to VDI/VDE 2174).

FUNCTION

REVERSE ACTING

Without an actuator being connected, the valve is held in closed position by means of a spring. With pressure on the spindle the valve opens. In connection with thermostats, pneumatic or electric valve actuators. The valves act as “cooling” valves, i.e. they open at rising temperatures.

FEATURES

- Simple design secures reliable controls and reduces costly downtime
- Location of the pack box in the actuator makes the valve service friendly

TECHNICAL DATA

Materials:

- Valve body	Gun metal RG 5 W.No. 2.1086
- Stem	Stainless steel W.No. 1.4436
- O-ring	70 NBR
- Gasket	Reinz-AFM34
Nominal pressure	PN 16
Seating	Double seated
Flow characteristic	Linear
Leakage rate	$\leq 0.5\%$ of Kvs
Regulating capability	Kvs/Kvr > 25
Connection threads	ISO 7-1

Reverse acting (normally closed)
For cooling water and lubricants

PRESSURE/TEMPERATURE DIAGRAM

According to DIN 2401

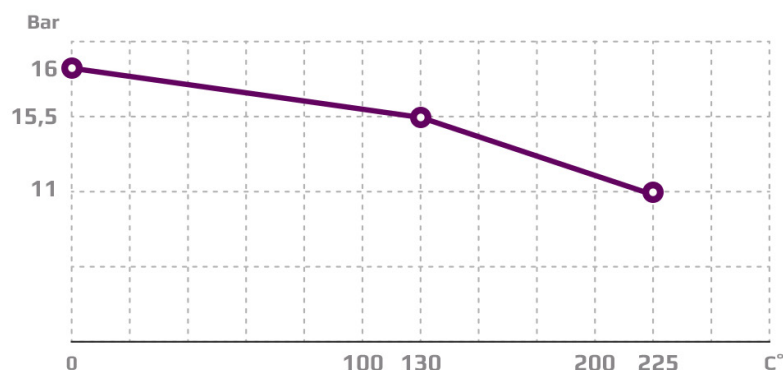

Subject to change without notice.

MOUNTING

The valve can be installed with vertical as well as horizontal spindles. For valve temperatures of max. 170 °C, the thermostat/ actuator can be fitted below or above the valve. For valve mounted with thermostats in media temperatures above 170 °C, a cooling unit has to be applied with connection downwards (please refer to data sheet for thermostat accessories). For electric actuators a high temperature adaptor must be used (please refer to data sheets for the electric actuators).

DIMENSION SKETCH

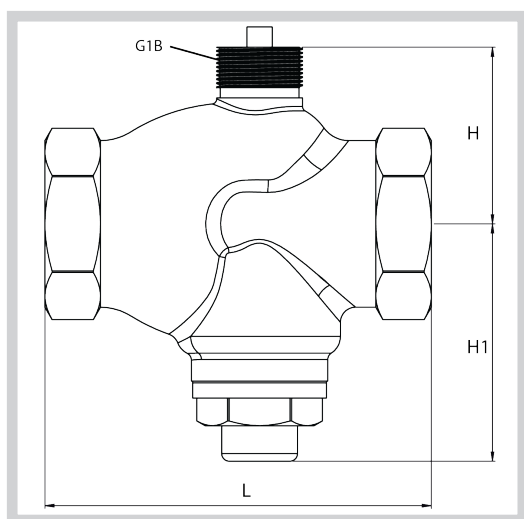

Type	L (mm)	H (mm)	H1 (mm)
40 L2SR	129	65	90
50 L2SR	153	70	94

SPECIFICATIONS

Type	Connection R_p	Opening dia. Mm	k_{vs} -value m^3/h	Rated travel mm	Max. Δp_L bar	Actuator Force N	Corresp. p_{1max} bar	Weight kg
40 L2SR	1½"	40	20.00	8	2.7	400	16.0	3.0
50 L2SR	2"	50	30.00	9	1.8	400	16.0	4.0



3-way Control Valve type L3S

Gun metal, PN 10, DN 15 – 50 mm

0-2.2.07-K

Page 1 of 2

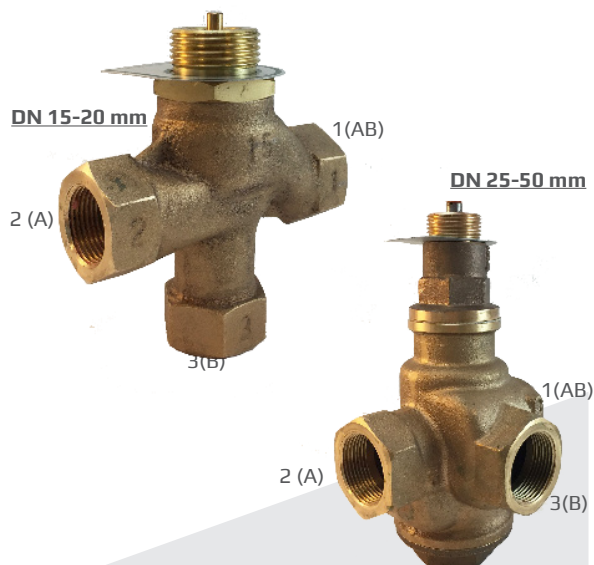

TECHNICAL DATA

Materials:

- Valve body, seats and cone	Gun metal RG 5
- O-ring	90 NBR
- Gasket	Reinz-AFM34
Nominal pressure	PN 10
	(max. 120°C option 200°C)

Seating	Two single seats
	15-20 mm unbalanced
	25-50 mm balanced

Flow characteristic	Almost linear
Leakage rate	≤ 0.5% of Kvs
Regulating capability	Kvs/Kvr > 25
Way of operation	When spindle is actuated:

	Gate 1-2 closes
	Gate 1-3 opens
Internal connection threads	ISO 7/1

APPLICATIONS

Control valves type L3S are designed for regulating fresh water, cold and hot sea-water and lubricating liquids. The valves are used in conjunction with temperature regulators in control systems for cooling and heating of domestic premises, district heating, industrial processes or marine installations.

DESIGN

The valve components - valve body, seats and cone - are made of sea-water resistant gun metal RG 5. The valves are single seated. The leakage rate is less than 0.5% of the full flow (according to VDI/VDE 2174). Note: The design of the sizes DN 15 (½") and DN 20 (¾") is different from the bigger ones.

FUNCTION

Without an actuator being connected, connection 2-1 is fully open and connection 3-1 completely closed by means of a spring. On increasing pressure on the spindle, the opening of the ports changes proportionally to the travel of the spindle, and when the spindle is pressed to the bottom, connection 3-1 is fully open and connection 2-1 completely closed.

FEATURES

- Sea water resistant
- Simple design secures reliable controls and reduces costly downtime

PRESSURE/TEMPERATURE DIAGRAM

According to DIN 2401

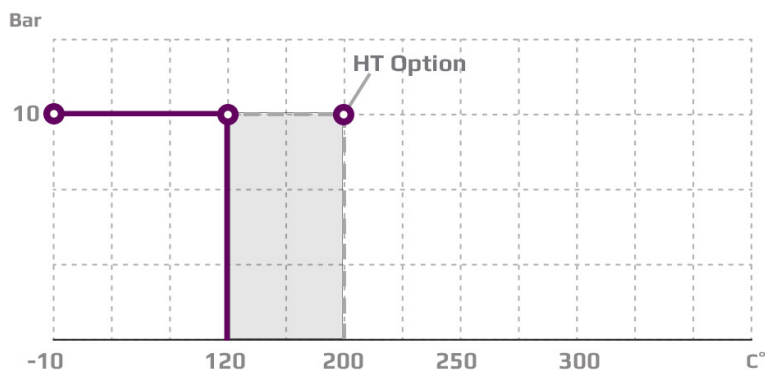

Subject to change without notice.

PORT NUMBERING

The ports of valves type L35 are marked with the figures 1, 2 and 3. The letters in parentheses refer to the corresponding internationally adapted designations.

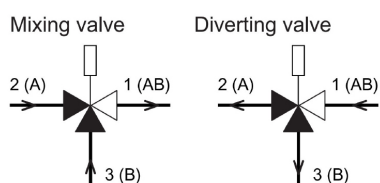

Port 1(AB) common port always open
 Port 2(A) closes at load on spindle
 Port 3(B) opens at load on spindle

MOUNTING

The valves can be installed with vertical as well as horizontal spindles. The thermostat/actuator can be fitted below or above the valve.

DIMENSION SKETCH

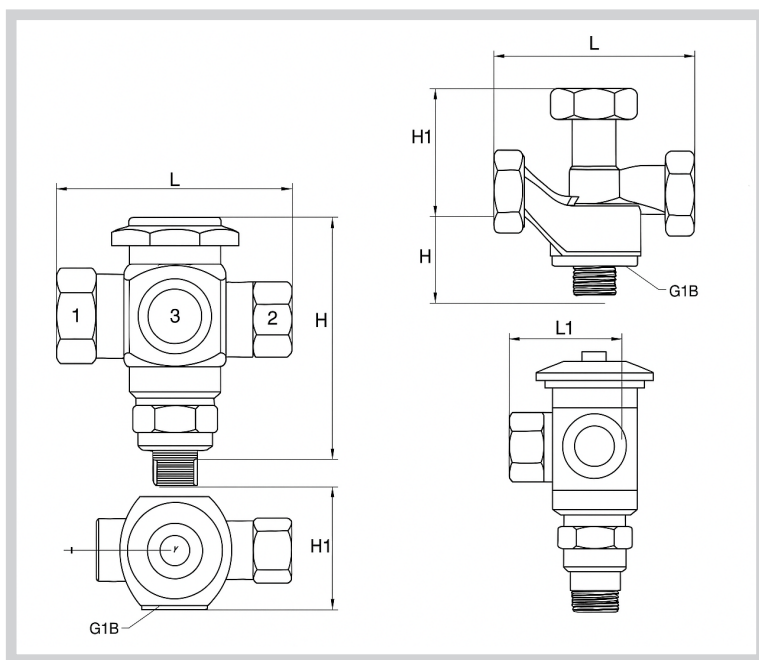

Type	L (mm)	L1 (mm)	H (mm)	H1 (mm)
15 L35	110	-	60	55
20 L35	110	-	60	55
25 L35	140	70	145	80
32 L35	140	70	145	80
40 L35	185	95	150	105
50 L35	185	95	150	105

SPECIFICATIONS

Type	Connection threads	DN mm	Opening mm	k_{vs} -value mixing value m^3/h	k_{vs} -value diverting valve m^3/h	Lifting height mm	Weight kg
15 L35	Rp 1/2	15	15	2.75	2.4	3	1
20 L35	Rp 3/4	20	20	5	4.3	4	1
25 L35	Rp 1	25	25	7.5	6.4	4	4.4
32 L35	Rp 1 1/4	32	32	12.5	10.7	6	4.5
40 L35	Rp 1 1/2	40	40	20	17.2	6	7,7
50 L35	Rp 2	50	50	30	25.8	8	8,3

3-way Control Valve type L3F

Gun metal, PN 10, DN 65 – 150 mm

0-2.2.08-K

Page 1 of 2

APPLICATIONS

Control valves type L3F are designed for regulating hot water - and cold and hot sea water. The valves are used in connection with one of our temperature regulators in control systems for industrial processes or marine installations.

DESIGN

The valve components - valve body, seats, cone and spindle - are made of sea water resistant materials with connection flanges drilled according to DIN 86021. The connection thread for the actuator is G1B.

FUNCTION

Without an actuator being installed, connection 2-1 is fully open and connection 3-1 completely closed, by means of a spring. By increasing pressure on the spindle, the opening of the ports changes proportionally to the travel of the spindle, and when the spindle is pressed to the bottom, connection 3-1 is fully open and connection 2-1 completely closed.

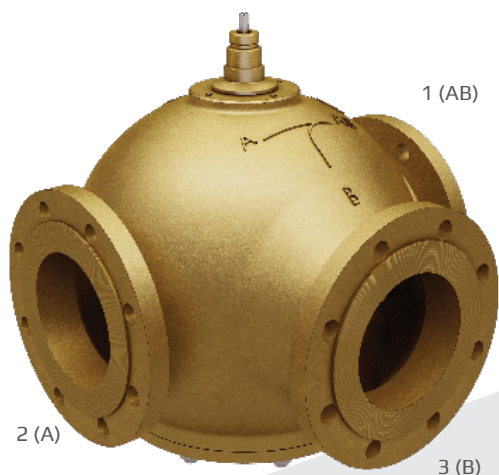

TECHNICAL DATA

Materials:

- Valve body	CuSn10
- Seats, cone, spindle	CuAl10Fe5Ni5
- O-ring	90 NBR
- Gasket	Reinz-AFM34
Nominal pressure	PN 10
Seating	2 balanced seats
Flow characteristic	Almost linear
Leakage rate	$\leq 0.5\%$ of Kvs
Regulating capability	Kvs/Kvr > 25
Flanges drilled according to	DIN 86021

Important note

In case the valves are applied as diverting valves, the pressure drop will increase by 35% and the Kvs-value will decrease by 14% as against mixing valves.

FEATURES

- Sea water resistant
- Simple design secures reliable controls and reduces costly downtime

PRESSURE/TEMPERATURE DIAGRAM

According to DIN 2401

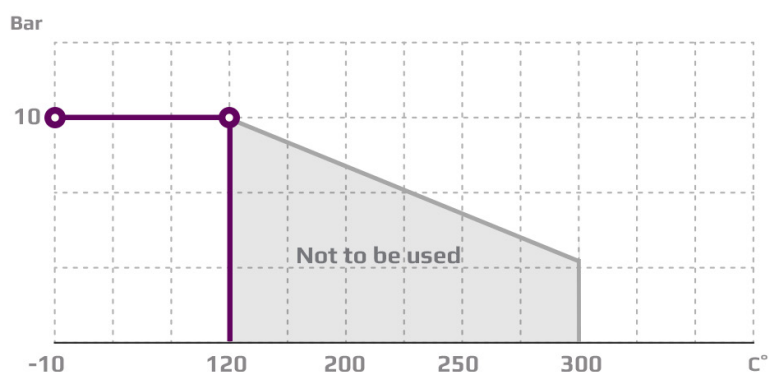

Subject to change without notice.

PORT NUMBERING

The ports of valves type L3F are marked with the letters AB, A and B.

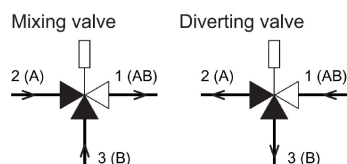

Port 1(AB)
Port 2(A)
Port 3(B)

common port always open
closes at load on spindle
opens at load on spindle



MOUNTING

The valves can be installed with vertical as well as horizontal spindles. The valves must be mounted in a way that the actuator will be exposed to a minimum of moisture and unnecessary vibrations.

DIMENSION SKETCH

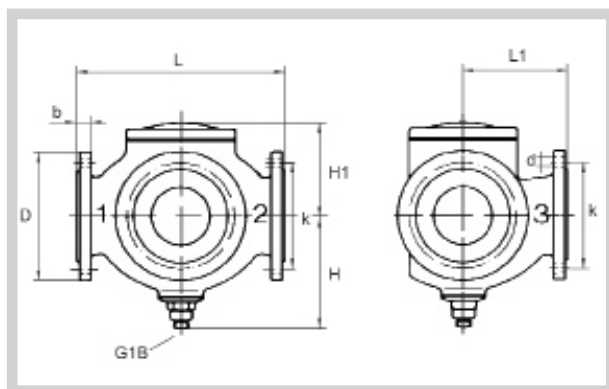

Type	L (mm)	L1 (mm)	H (mm)	H1 (mm)	D (dia.) (mm)	b (mm)	k (dia.) (mm)	d mm dia. (num-)
65 L3F	240	120	175	120	185	20	145	18x(4)
80 L3F	310	155	180	127	200	22	160	18x(8)
100 L3F	350	175	195	145	220	22	180	18x(8)
125 L3F	400	240	245	180	250	24	210	18x(8)
150 L3F	480	270	280	189	285	24	240	22x(8)

SPECIFICATIONS

Type	Flange connection DN in mm	Opening mm	Mixing valve k_{vs} -value m^3/h	Diverting valve k_{vs} -value m^3/h	Lifting height mm	Weight kg
65 L3F	65	65	50	43	10.5	22.5
80 L3F	80	80	80	69	11	40
100 L3F	100	100	125	108	13	55
125 L3F	125	125	215	185	18	91

3-way control valve type L3FA

Gun metal, PN 10, DN 65 – 200 mm / PN 6, DN 300/250 – 300 mm

0-2.2.09.01-B

Page 1 of 2

APPLICATIONS

Control valve type L3FA is designed for regulating of sea water. The valves are used in conjunction with marine installations, e.g. cooling of main and auxiliary engines. Designed for use in conjunction with Clorius valve motor type AVM234 or AVF234.

DESIGN

The valve components (seats, cone and spindle) are made of alu bronze and the valve body is made of CuSn10. The valve flanges are drilled according to DIN 86021.

FUNCTION

The valve cone is firmly connected with the motor spindle. When the valve cone is in the one outer position by draw on the spindle, connection A-AB is kept fully open and connection B-AB is fully closed. In the other outer position connection A-AB is fully closed and connection B-AB is fully open. In the intermediate positions the opening degrees change proportionally.



TECHNICAL DATA

Materials:

- Valve body	CuSn10
- Seat, cone, spindle	CuAL10Fe5Ni5
- O-ring	AFLAS 75H
- Gasket	Reinz-AFM34

Nominal pressure

- 65-200 mm	PN 10 max. 120°C
- 300/250-300 mm	PN 6 max. 120°C

Seats 2 balanced single seats

Flow characteristic Almost linear

Leakage rate ≤ 0.5%

Regulating capability Kvs/Kvr > 25

Temperature range Max. 120 °C

Flanges According to DIN 86021

Note!

Valve type 300/250 L3FA has outer measures and flanges drilled as valve type 300 L3FA

For cooling and heating purposes
Sea water resistant

Important note

In case the valves are applied as diverting valves, the pressure drop will increase by 35% and the kvs-value will decrease by 14% as against mixing

Subject to change without notice.

FEATURE

- Sea water resistant
- Simple design secures reliable controls and reduces costly downtime
- Can be used for both mixing and diverting

PRESSURE/TEMPERATURE DIAGRAM

According to DIN 2401

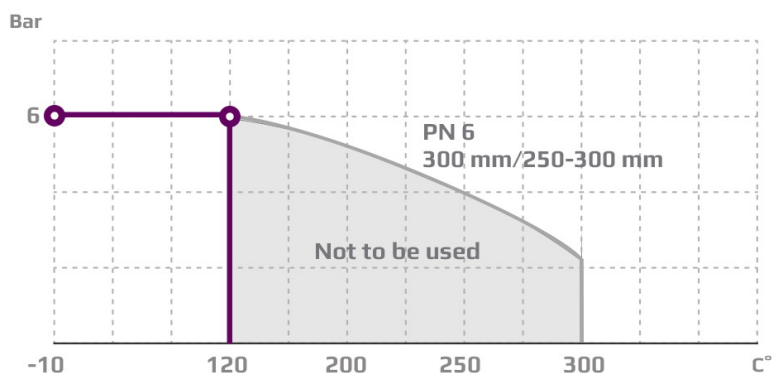
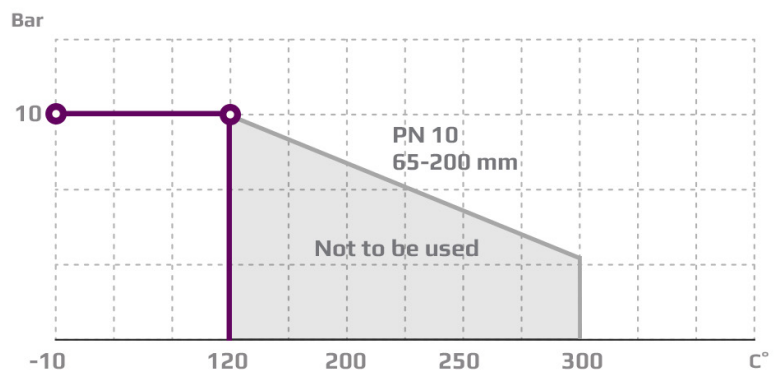

PORT NUMBERING

The ports of valves type L3FA are marked with the letters AB, A and B.

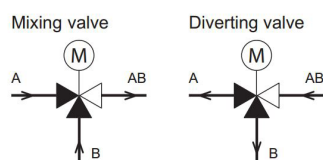

Port AB
Port A
Port B

common port always open
closes at load on spindle
opens at load on spindle

MOUNTING

The valve can be installed vertical as well as horizontal. The valve must be mounted in a way that the valve motor will be exposed to a minimum of moisture and unnecessary vibrations. Free height above / below the valve must be minimum 400 mm for mounting and operation of the AVM234 See drawing.

DIMENSION SKETCH

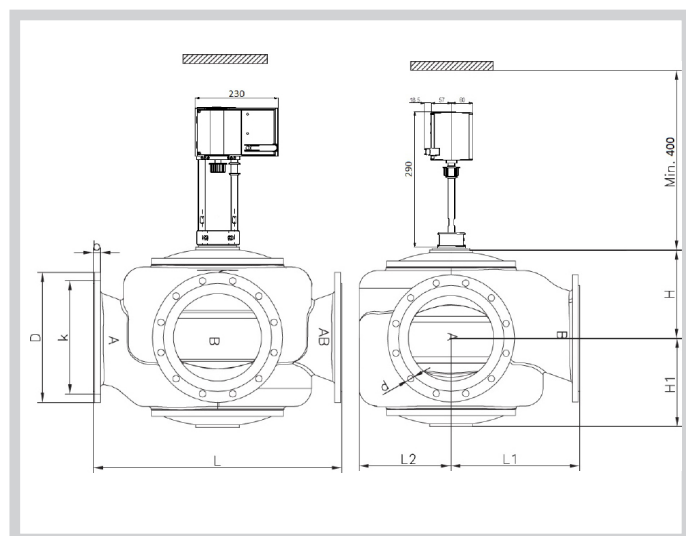

Type	L mm	L1 mm	H mm	H1 mm	b mm	D (dia.)	k (dia.)	d mm dia.
65 L3FA	-	-	-	-	-	-	-	-
80 L3FA	310	155	117	127	19	200	160	18x(8)
100 L3FA	350	175	132	141	19	220	180	18x(8)
125 L3FA	400	240	181	171	19	250	210	18x(8)
150 L3FA	480	270	216	189	19	285	240	22x(8)
200/175 L3FA	600	325	238	238	20	340	295	22x(8)
200 L3FA	600	325	238	238	20	340	295	22x(8)
300/250 L3FA ²⁾	850	450	305	305	25	445	400	22x(12)
300 L3FA	850	450	305	305	25	445	400	22x(12)

Type	Flange connection DN in mm	Opening (mm)	k_{vs} -value ¹⁾ Mixing valve m ³ /h	k_{vs} -value ¹⁾ Diverting valve m ³ /h	Lifting height (mm)	Weight (kg)
65 L3FA	-	-	-	-	-	-
80 L3FA	80	80	80	69	11	40
100 L3FA	100	100	125	108	13	49
125 L3FA	125	125	215	185	18	80
150 L3FA	150	150	310	267	20	126
200/175 L3FA	200	175	425	366	22	195
200 L3FA	200	200	555	477	28	190
300/250 L3FA ¹⁾	300	250	865	744	28	365
300 L3FA	300	300	1250	1075	45	355



3-way Control Valve type L3FM-T

Bronze, PN16, DN65 - 125mm/ PN10, DN150 - 300mm/ PN6, DN350 - 800mm

0-2.2.10-H

Page 1 of 4



APPLICATIONS

Control valve type L3FM-T is a three-way control valve with a slide for quarter turn operation designed for regulating of sea water. The valves are designed for use in conjunction with valve motor type CAR-H with handle for manual operation or for use in conjunction with a pneumatic actuator.

DESIGN

The valve body is made of bronze, while the slide is made of alu. bronze. The valve flanges are drilled according to EN 1092-2.

FUNCTION

The slide is firmly connected with the actuator spindle. When the slide is in the one extreme position by turning the spindle, connection A-AB is kept fully open and connection B-AB is fully closed. In the other extreme position connection A-AB is fully closed and connection B-AB is fully open. In the intermediate positions the opening degrees change proportionally. The valve has a small tolerance between body and slide. To minimize the leakage an O-ring is mounted in a groove on the slide.

TECHNICAL DATA

Materials:

- Valve body	CuSn10
- Slide	CuAL10Fe5Ni5
- O-ring	NBR 70A
- U-ring	PTFE
- Gasket	AF1000

- Nominal pressure	
DN 65-125 L3FM-T	PN 16, max. 100°C (option 120°C)
DN 150-300 L3FM-T	PN 10, max. 100°C (option 120°C)
DN 350-800 L3FM-T	PN 6, max. 100°C (option 120°C)

Flow characteristic	Almost linear
Leakage rate	max 0.5%
Regulating capability	Kvs/Kvr > 25
Flanges	EN 1092-2 PN 6/10 /16

Counter flanges (suggested)	DIN 2631 - PN 6 DIN 2632 - PN 10 DIN 2633 - PN 16
-----------------------------	---------------------------------------------------------

Max. pressure Δp_L , against which the control can close:

- 65-125 L3FM-T	16 bar
- 150-300 L3FM-T	10 bar
- 350-800 L3FM-T	6 bar

Subject to change without notice.

FEATURE

- Sea water resistant
- Simple design secures reliable controls and reduces costly downtime
- Low leakage rate secures energy savings
- Flexible choice of port placements
- Can be used for both mixing and diverting

PRESSURE/TEMPERATURE DIAGRAM

According to DIN 2401

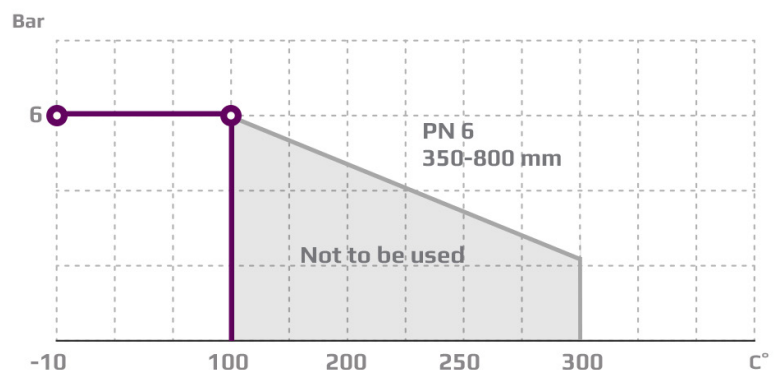

PRESSURE/TEMPERATURE DIAGRAM

According to DIN 2401

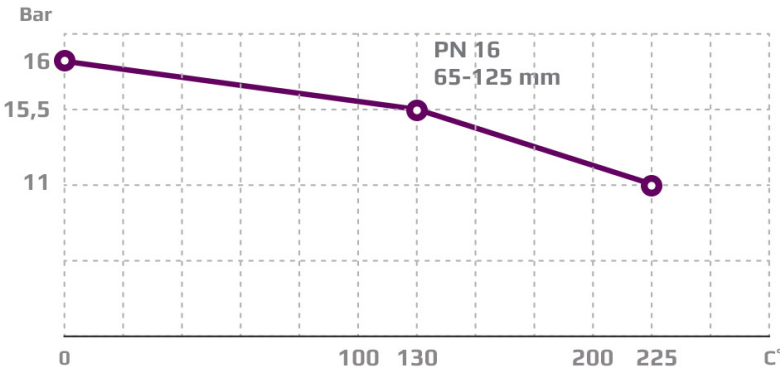
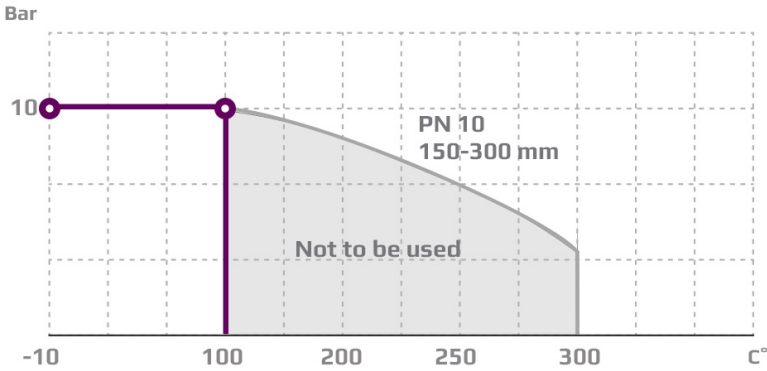

PORT NUMBERING/CONFIGURATION

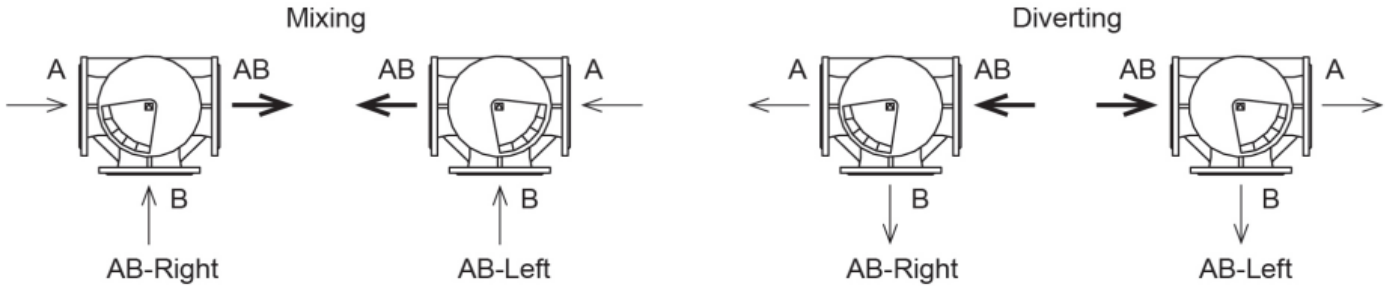

Further specification for ordering (e.g. 400 L3FM-T, AB-Right)

MOUNTING

The valve connections are marked A, B and AB. The slide is operating between A and B. Check slide position before installation in the pipe. The slide position is marked on the top of the shaft. Valve can be supplied in two different configurations, AB-Right and AB-Left. A valve with AB-middle port is available on request. Please note that the supplied configuration is according to installation. The valve can be installed with vertical as well as horizontal spindles. The valve must be mounted in a way that the valve actuator will be exposed to a minimum of moisture and unnecessary vibrations.

3-way Control Valve type L3FM-T

Bronze, PN16, DN65 - 125mm/ PN10, DN150 - 300mm/ PN6, DN350 - 800mm

0-2.2.10-H

Page 3 of 4

DIMENSION SKETCH

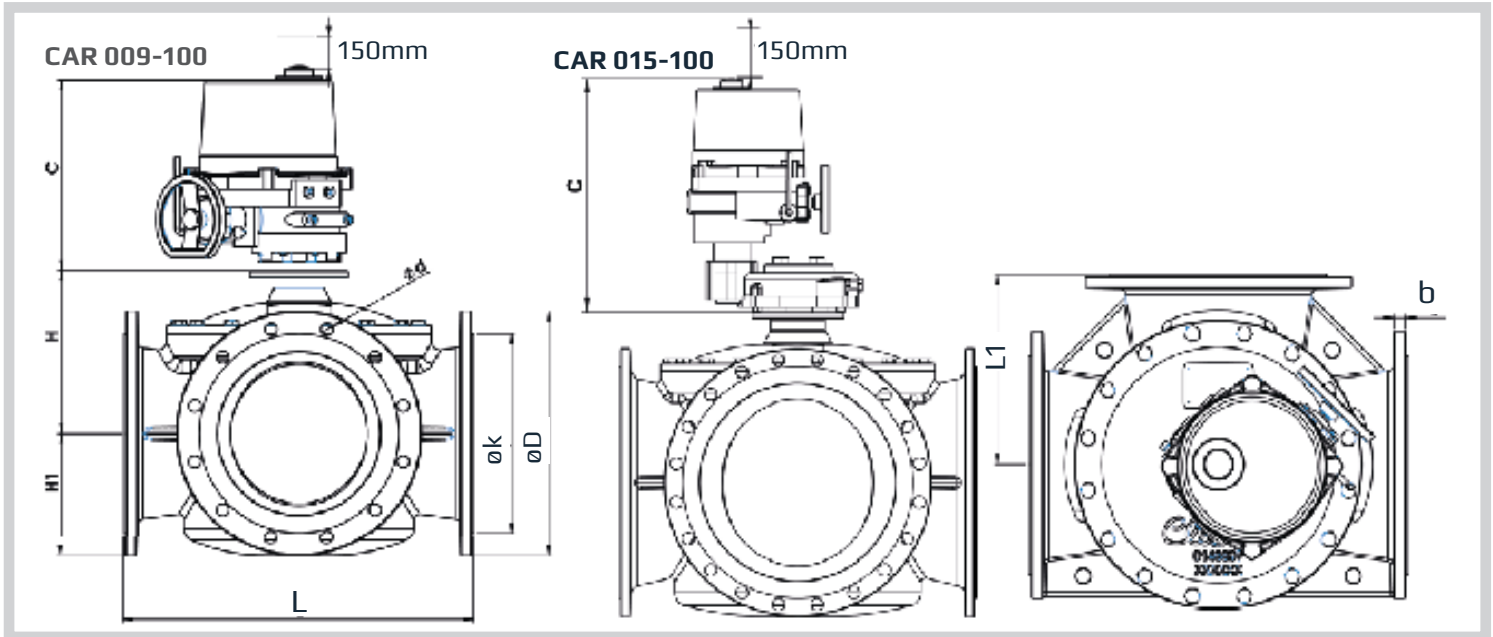

Type	Pressure DN	L mm	L1 mm	H mm	H1 mm	b mm	c mm	EN 1092-2			ANSI Class 150			JIS B 2210 5K			JIS B 2210 10K		
								D (dia.) mm	k (dia.) mm	d mm dia. no.	D (dia.) mm	k (dia.) mm	d mm dia. no.	D (dia.) mm	k (dia.) mm	d mm dia. no.	D (dia.) mm	k (dia.) mm	d mm dia. no.
65 L3FM-TR	16	292	146	135	90	20	273	185	145	19x(4)	180	140	19x(4)	155	130	15x(4)	175	140	19x(4)
80 L3FM-TR	16	292	146	140	94	20	273	200	160	19x(8)	190	152	19x(4)	180	145	19x(4)	185	150	19x(8)
100 L3FM-TR	16	350	175	158	112	17	273	220	180	19x(8)	230	190.5	19x(8)	200	165	19x(8)	210	175	19x(8)
125 L3FM-TR	16	400	200	179	123	17	273	250	210	19x(8)	255	216	22x(8)	235	200	19x(8)	250	210	23x(8)
150 L3FM-TR	16	438	219	196	139	20	276	285	240	23x(8)	280	241	22x(8)	265	230	19x(8)	280	240	23x(8)
200 L3FM-TR	10	530	270	236	175	21	361	340	295	23x(8)	343	298	22x(8)	320	280	23x(8)	330	290	23x(12)
250 L3FM-TR	10	592	300	273	205	23	361	400	350	23x(12)	405	362	25x(12)	385	345	23x(12)	400	355	25x(12)
300 L3FM-TR	10	649	330	305	230	25.5	361	455	400	23x(12)	483	432	25x(12)	430	390	23x(12)	445	400	25x(16)
350 L3FM-TR	6	717	360	337	255	25.5	361	490	445	23x(12)	534	477	29x(12)	480	435	25x(12)	490	445	25x(16)
400 L3FM-TR	6	770	385	375	285	26	361	540	495	23x(16)	597	540	29x(16)	540	495	25x(16)	560	510	27x(16)
450 L3FM-TR	6	820	410	391	310	26.5	556	595	550	23x(16)	635	578	32x(16)	605	555	25x(16)	620	565	27x(20)
500 L3FM-TR	6	900	455	425	340	27.5	556	645	600	23x(20)	699	635	32x(20)	655	605	25x(20)	675	620	27x(20)
550 L3FM-TR	6	900	455	425	373	27.5	556	-	-	-	-	-	-	720	665	27x(20)	745	680	33x(20)
600 L3FM-TR	6	1000	505	470	393	31.0	556	755	705	28x(20)	813	750	35x(20)	770	715	25x(20)	795	730	33x(24)
650 L3FM-TR	6	1050	525	515	423	35	556	-	-	-	-	-	-	825	770	27x(24)	845	780	33x(24)
700 L3FM-TR	6	1106	553	519	462	34.0	556	860	810	28x(24)	-	-	-	875	820	27x(24)	905	840	33x(24)
800 L3FM-TR	6	1200	600	579	507	37	556	975	920	31x(24)	-	-	-	995	930	32x(24)	1020	950	33x(28)

SPECIFICATIONS

Type	Flange connection DN in mm	k_{vs} -value ¹⁾ Mixing valve m ³ /h	k_{vs} -value ¹⁾ Diverting valve m ³ /h	Torque Nm For inlet P*	Weight kg
65 L3FM-T	65	95	120	46	28
80 L3FM-T	80	122	154	55	32
100 L3FM-T	100	175	220	90	47
125 L3FM-T	125	245	330	150	64
150 L3FM-T	150	395	425	160	75
200 L3FM-T	200	800	1100	250	114
250 L3FM-T	250	1500	2100	395	159
300 L3FM-T	300	2000	2650	550	207
350 L3FM-T	350	2530	3380	640	278
400 L3FM-T	400	3050	3950	895	346
450 L3FM-T	450	3680	4480	1050	433
500 L3FM-T	500	4150	5250	1300	563
550 L3FM-T	550	4150	5250	1300	575
600 L3FM-T	600	4800	6050	1850	816
700 L3FM-T	700	5500	7000	TBC	1150
800 L3FM-T	800	6200	8000	2600	2100

1) kvs-value for port A and B 50% open.

*Torque calculated at max inlet P for:

DN 65 - 125 = 16 Bar

DN 150-300 = 10 Bar

DN 350-800 = 5 Bar

3-way Control Valve type L3FMT-SL

Bronze, PN10, DN50 - 400mm

0-2.6.23-A

Page 1 of 6

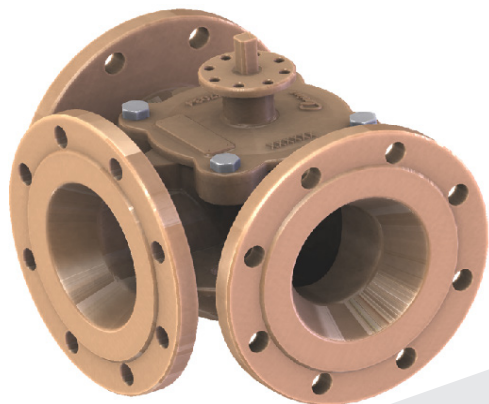

APPLICATIONS

Control valve type L3FMT-SL is a three-way control valve with a slide for quarter turn operation designed for regulating of sea water, lubricating oil and other liquid media. The valves are designed for use in conjunction with industrial processes, district heating and marine installations with large water or lubricating oil volumes:

- Engine Jacket Cooling Water System
- Lubricating Oil Cooling
- Central Cooling Water System, etc.

The valves are designed for use in conjunction with electric actuator type CAR-H with handle for manual operation or for use in conjunction with a pneumatic actuator type VT.

DESIGN

The valve body is made of bronze and the slide is made of alu. bronze. The valve flanges are drilled according to EN 1092-2. Option: JIS B 2210 5K/10K and ANSI class 150.

FUNCTION

The slide is firmly connected with the motor spindle. When the slide is in the one outer position by turning the spindle, connection A-AB is fully open and connection B-AB is fully closed. In the other outer position connection A-AB is fully closed and connection B-AB is fully open. In the intermediate positions the opening degrees change proportionally. The valve has a small tolerance between body and slide.

Connection described for AB-Left valves - reverse connection for AB-Right valves.

This section to be read together with sketches page 2 this data sheet.

TECHNICAL DATA

Materials:	
- Valve body	Bronze
- Slide	Aluminium bronze
- O-ring	NBR
Flow characteristic	Almost linear
Leakage rate	ANSI class I
Flanges	EN 1092-2 PN 10
- Option	JIS B 2210 5K/10K ANSI class 150
Max. pressure Δp, against which the valve can close	5 bar
Nominal pressure	PN 10
Design temperature	120°C

FEATURES

- Simple design secures reliable controls and reduces costly downtime
- Most compact valve on the market
- Full flexibility on port orientation AB right or AB left
- Sea water resistant

Subject to change without notice.

PORT NUMBERING: AB-RIGHT



PORT NUMBERING: AB-LEFT

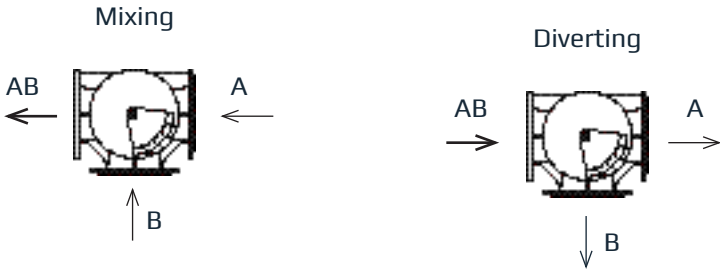

MOUNTING

The valve connections are marked A, B and AB. The slide is operating between A and B. Check slide position before installation in the pipe. The slide position is marked on the top of the shaft. The valves can be installed with vertical as well as horizontal spindles. The valves must be mounted in a way that the valve actuator will be exposed to a minimum of moisture and unnecessary vibrations.

3-way Control Valve type L3FMT-SL

Bronze, PN10, DN50 - 400mm

O-2.6.23-A

Page 3 of 6

DIMENSION SKETCH

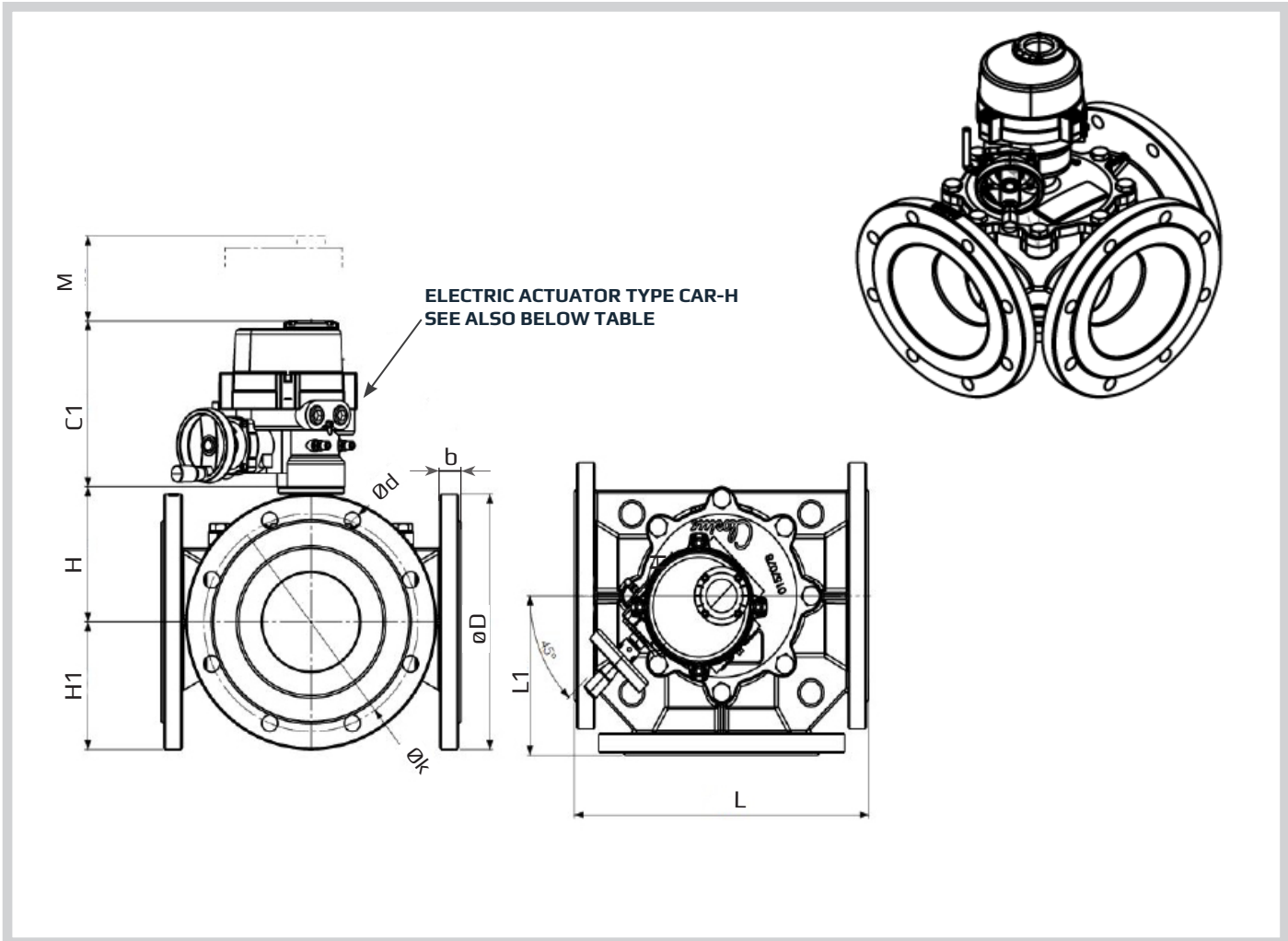

To be read together with table 1 on page 4

SPECIFICATIONS - TABLE 1 (read this together with sketch on page 3)

Type	L (mm)	L1 (mm)	H (mm)	H1 (mm)	b (mm)	C1 (mm)	M (mm)	Electric Actuator Type CAR-H
50 L3FMT-SL (HF)	254	127	114,5	ØD/2	19	223	110	CAR-H 006
65 L3FMT-SL	254	127	114,5	ØD/2	19	223	110	CAR-H 006
65 L3FMT-SL (HF)	254	127	125,5	ØD/2	19	223	110	CAR-H 006
80 L3FMTSL	254	127	125,5	ØD/2	19	223	110	CAR-H 006
80 L3FMT-SL (HF)	254	127	130,5	ØD/2	19	223	110	CAR-H 006
100 L3FMT-SL	296	148	130,5	ØD/2	24	223	110	CAR-H 006
100 L3FMT-SL (HF)	296	148	134,5	ØD/2	24	223	110	CAR-H 006
125 L3FMT-SL	330	165	139,5	ØD/2	24	223	110	CAR-H 006
125 I3FMT-SL JIS5K	320	160	139,5	ØD/2	19	223	110	CAR-H 006
150 L3FMT-SL	356	178	148,5	ØD/2	25,4	223	110	CAR-H 006
200 L3FMT-SL	410	205	181,5	ØD/2	28,4	223	110	CAR-H 010
250 L3FMT-SL	480	240	202	ØD/2	31	223	110	CAR-H 010
300 L3FMT-SL (RF)	580	290	202	ØD/2	32	223	110	CAR-H 010
300 L3FMT-SL	560	280	237	ØD/2	32	261	150	CAR-H 020
350 L3FMT-SL	660	330	256	ØD/2	36	261	--	CAR-H 024
400 L3FMT-SL	720	360	277,5	ØD/2	38	315	180	CAR-H 035
400 L3FMT-SL (HF)	720	360	314	ØD/2	25	315	180	CAR-H 035

RF = Reduced Flow
 HF = High Flow

ØD/2 - Depends on flange type (see also table 2)

3-way Control Valve type L3FMT-SL

Bronze, PN10, DN50 - 400mm

O-2.6.23-A

Page 5 of 6

Flange connections	EN 1092-2			ANSI Class 150			JIS B 2210 5K			JIS B 2210 10K		
	D (dia.) (mm)	k (dia.) (mm)	d mm dia. (number)	D (dia.) (mm)	k (dia.) (mm)	d mm dia. (number)	D (dia.) (mm)	k (dia.) (mm)	d mm dia. (number)	D (dia.) (mm)	k (dia.) (mm)	d mm dia. (number)
DN50	165	125	19x(4)	152	121	19x(4)	130	105	15x(4)	155	120	19x(4)
DN65	185	145	19x(4)	178	140	19x(4)	155	130	15x(4)	175	140	19x(4)
DN80	200	160	19x(8)	190	152	19x(4)	180	145	19x(4)	185	150	19x(8)
DN100	220	180	19x(8)	230	191	19x(8)	200	165	19x(8)	210	175	19x(8)
DN125	250	210	19x(8)	255	216	22x(8)	235	200	19x(8)	250	210	23x(8)
DN150	285	240	23x(8)	280	241	22x(8)	265	230	19x(8)	280	240	23x(8)
DN200	343	295	22x(8)	343	298	22x(8)	320	280	23x(8)	330	290	23x(12)
DN250	405	350	23x(12)	405	362	25x(12)	385	345	23x(12)	400	355	25x(12)
DN300	455	400	23x(12)	483	432	25x(12)	430	390	23x(12)	445	400	25x(16)
DN350	505	460	23x(16)	533	476	29x(12)	480	435	25x(12)	490	445	25x(16)
DN400	565	515	28x(16)	597	540	29x(16)	540	495	25x(16)	560	510	27x(16)

SPECIFICATIONS - TABLE 3

Type	Flange connection	KvS m ³ /h	Torque Nm	Weight kg
DN50 (HF)	50	67	30	19
DN65	65	67	30	22
DN65 (HF)	65	120	35	23
DN80	80	100	35	24
DN80 (HF)	80	180	38	26
DN100	100	180	38	32
DN100 (HF)	100	270	40	34
DN125	125	260	40	41
DN150	150	430	45	50
DN200	200	770	90	80
DN250	250	1.230	115	114
DN300	300	2.030	160	153
DN300 (RF)	300	1.190	115	165
DN350	350	2.850	210	210
DN400	400	3.760	265	258
DN400 (HF)	400	5.200	330	248

*Torque calculated at max ΔP for: DN50 - 400 - 5 Bar

**NOTE: KvS is max. KvS value

RF = Reduced Flow

HF = High Flow

1

3-way Control Valve type L3FMT-ULL (Ultra Low Leakage)

Bronze, PN10, DN50 - 400mm

0-2.6.21-A

Page 1 of 6

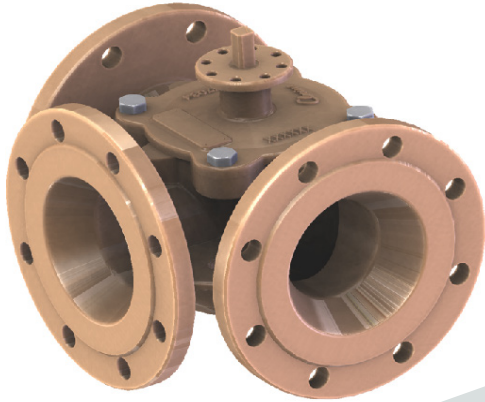

APPLICATIONS

Control valve type L3FMT-ULL is a three-way control valve with a slide for quarter turn operation designed for regulating of sea water, lubricating oil and other liquid media. The valves are designed for use in conjunction with industrial processes, district heating and marine installations with large water or lubricating oil volumes:

- Engine Jacket Cooling Water System
- Lubricating Oil Cooling
- Central Cooling Water System, etc.

The valves are designed for use in conjunction with electric actuator type CAR-H with handle for manual operation or for use in conjunction with a pneumatic actuator type VT.

DESIGN

The valve body is made of bronze and the slide is made of alu. bronze. The valve flanges are drilled according to EN 1092-2. Option: JIS B 2210 5K/10K and ANSI class 150.

FUNCTION

The slide is firmly connected with the motor spindle. When the slide is in the one outer position by turning the spindle, connection A-AB is fully open and connection B-AB is fully closed. In the other outer position connection A-AB is fully closed and connection B-AB is fully open.

TECHNICAL DATA

Materials:	
- Valve body	Bronze
- Slide	Aluminum bronze
- Sealing element and O-ring	Silicone/PTFE
Flow characteristic	Almost linear
Leakage rate	ANSI class IV/EN 1349 < 0.01%
Flanges	EN 1092-2 PN 10
- Option	JIS B 2210 5K/10K ANSI class 150
Max. pressure Δp , against which the valve can close bar	5
Nominal pressure	PN 10
Design temperature	120°C
Optional temperature	150°C

FEATURES

- Simple design secures reliable controls and reduces costly downtime
- Ultra Low Leakage rate secures energy savings - Best in class
- Most compact valve on the market
- Full flexibility on port orientation on AB right or AB left
- Sea water resistant

Subject to change without notice.

PORT NUMBERING: AB-RIGHT

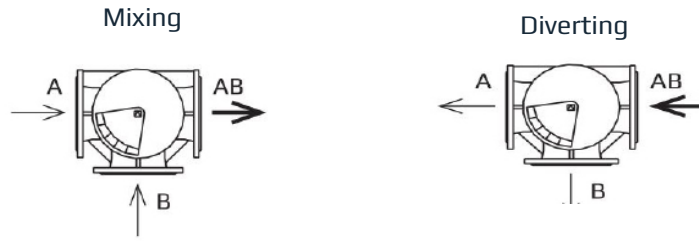

PORT NUMBERING: AB-LEFT

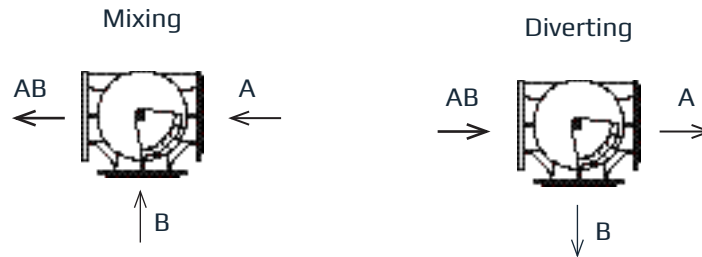

MOUNTING

The valve connections are marked A, B and AB. The slide is operating between A and B. Check slide position before installation in the pipe. The slide position is marked on the top of the shaft. The valves can be installed with vertical as well as horizontal spindles. The valves must be mounted in a way that the valve actuator will be exposed to a minimum of moisture and unnecessary vibrations.



*Torque calculated at max ΔP for: DN100 - DN50 - 5 Bar

3-way Control Valve type L3FMT-ULL (Ultra Low Leakage)

Bronze, PN10, DN50 - 400mm

0-2.6.21-A

Page 3 of 6

DIMENSION SKETCH

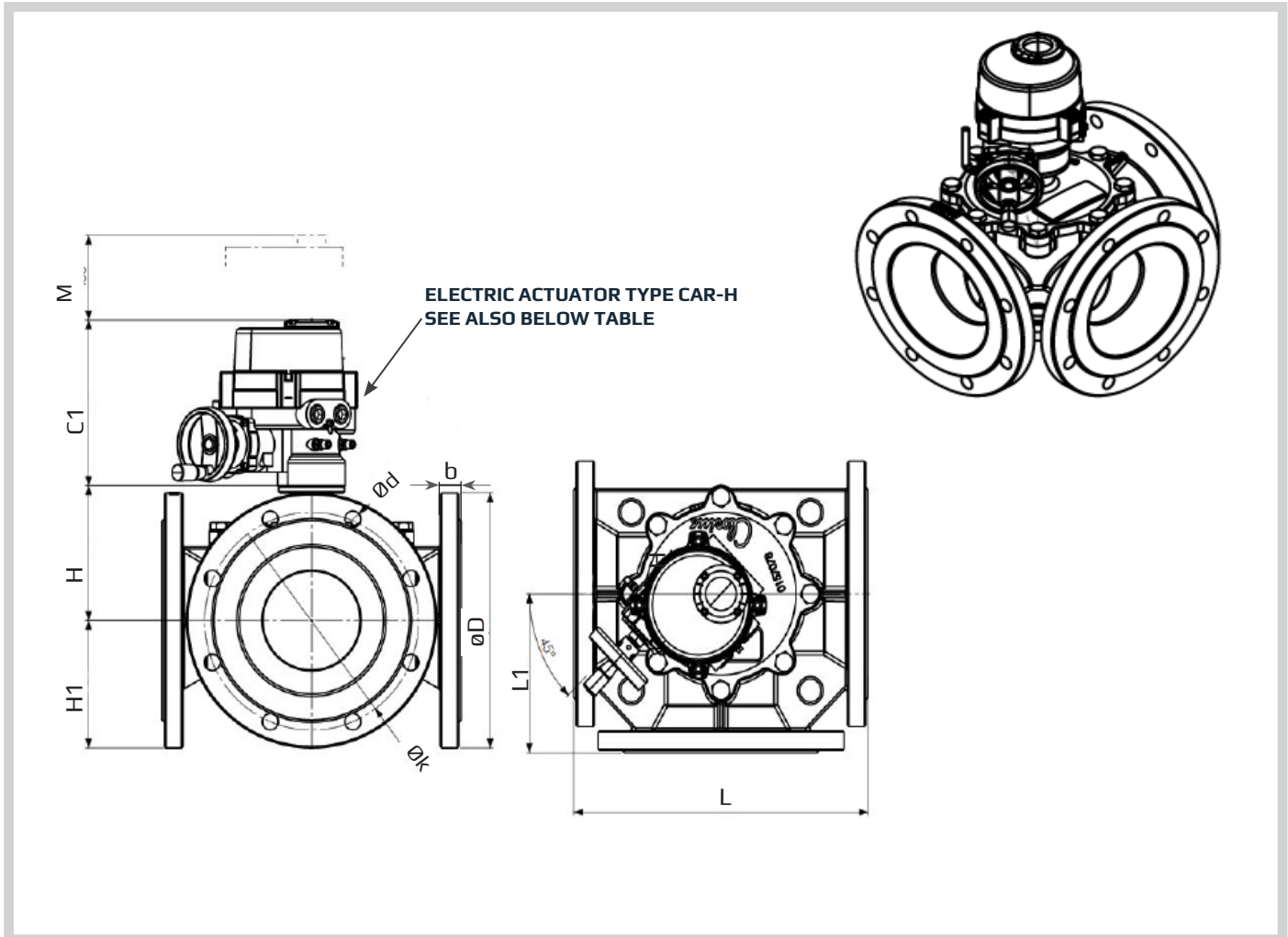

To be read together with table 1 on page 4

SPECIFICATIONS - TABLE 1 (read this together with table on page 4)

Type	L (mm)	L1 (mm)	H (mm)	H1 (mm)	b (mm)	C1 (mm)	M (mm)	Electric Actuator Type CAR-H
50 L3FMT-ULL (HF)	254	127	115	ØD/2	19	223	110	CAR-H 006
65 L3FMT -ULL	254	127	115	ØD/2	19	223	110	CAR-H 006
65 L3FMT -ULL (HF)	254	127	126	ØD/2	19	223	110	CAR-H 006
80 L3FMT-ULL	254	127	126	ØD/2	19	223	110	CAR-H 006
80 L3FMT-ULL (HF)	254	127	131	ØD/2	19	223	110	CAR-H 006
100 L3FMT-ULL	296	148	131	ØD/2	24	223	110	CAR-H 006
100 L3FMT-ULL (HF)	296	148	140	ØD/2	24	223	110	CAR-H 006
125 L3FMT-ULL	330	165	140	ØD/2	24	223	110	CAR-H 006
150 L3FMT-ULL	356	178	149	ØD/2	25,4	223	110	CAR-H 010
200 L3FMT-ULL	410	205	182	ØD/2	28,4	261	150	CAR-H 016
250 L3FMT-ULL	480	240	202	ØD/2	31	261	150	CAR-H -016
300 L3FMT-ULL (RF)	580	290	202	ØD/2	32	261	180	CAR-H -016
300 L3FMT-ULL	560	280	237	ØD/2	32	315	180	CAR-H -035
350 L3FMT-ULL	660	330	256	ØD/2	36	315	180	CAR-H 050
400 L3FMT-ULL	720	360	278	ØD/2	38	315	180	CAR-H 080
400 L3FMT-ULL (HF)	720	360	314	ØD/2	25	352	200	CAR-H 080

RF = Reduced Flow
 HF = High Flow

ØD/2 - Depends on flange type (see also table 2)

3-way Control Valve type L3FMT-ULL (Ultra Low Leakage)

Bronze, PN10, DN50 - 400mm

0-2.6.21-A

Page 5 of 6

SPECIFICATIONS

TABLE 2

Flange connections	EN 1092-2			ANSI Class 150			JIS B 2210 5K			JIS B 2210 10K		
	D (dia.) (mm)	k (dia.) (mm)	d mm dia. (number)	D (dia.) (mm)	k (dia.) (mm)	d mm dia. (number)	D (dia.) (mm)	k (dia.) (mm)	d mm dia. (number)	D (dia.) (mm)	k (dia.) (mm)	d mm dia. (number)
DN50	165	125	19x(4)	152	121	19x(4)	130	105	15x(4)	155	120	19x(4)
DN65	185	145	19x(4)	178	140	19x(4)	155	130	15x(4)	175	140	19x(4)
DN80	200	160	19x(8)	190	152	19x(4)	180	145	19x(4)	185	150	19x(8)
DN100	220	180	19x(8)	230	191	19x(8)	200	165	19x(8)	210	175	19x(8)
DN125	250	210	19x(8)	255	216	22x(8)	235	200	19x(8)	250	210	23x(8)
DN150	285	240	23x(8)	280	241	22x(8)	265	230	19x(8)	280	240	23x(8)
DN200	343	295	22x(8)	343	298	22x(8)	320	280	23x(8)	330	290	23x(12)
DN250	405	350	23x(12)	405	362	25x(12)	385	345	23x(12)	400	355	25x(12)
DN300	455	400	23x(12)	483	432	25x(12)	430	390	23x(12)	445	400	25x(16)
DN350	505	460	23x(16)	533	476	29x(12)	480	435	25x(12)	490	445	25x(16)
DN400	565	515	28x(16)	597	540	29x(16)	540	495	25x(16)	560	510	27x(16)

SPECIFICATIONS - TABLE 3

Type	Flange connection	KvS m ³ /h**	Torque Nm	Weight kg
DN50 (HF)	50	67	30	19
DN65	65	67	30	22
DN65 (HF)	65	120	30	23
DN80	80	100	35	24
DN80 (HF)	80	180	35	26
DN100	100	180	38	32
DN100 (HF)	100	270	38	34
DN125	125	260	40	41
DN150	150	430	90	50
DN200	200	770	120	80
DN250	250	1.230	150	114
DN300	300	2.030	320	153
DN350	350	2.850	418	210
DN400	400	3.760	530	258
DN400 (HF)	400	5.200	650	248

*Torque calculated at max ΔP for: DN50 - DN400 - 5 Bar

**NOTE: KvS is max. KvS value

HF = High Flow

3-way Control Valve type L3FMT-ULLM Ultra Low Leakage (Middle)

Bronze, PN10, DN125 - DN 200 mm

0-2.6.22-A

Page 1 of 4

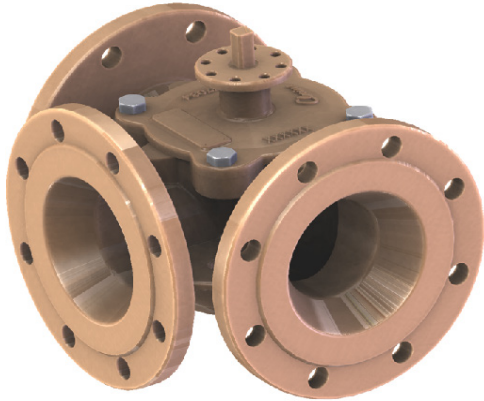

APPLICATIONS

Control valve type L3FMT-ULLM is a three-way control valve with a slide for quarter turn operation designed for regulating of sea water, lubricating oil and other liquid media. The valves are designed for use in conjunction with industrial processes, district heating and marine installations with large water or lubricating oil volumes:

- Engine Jacket Cooling Water System
- Lubricating Oil Cooling
- Central Cooling Water System, etc.+

The valves are designed for use in conjunction with electric actuator type CAR-H with handle for manual operation or for use in conjunction with a pneumatic actuator type VT.

DESIGN

The valve body is made of bronze and the slide is made of alu. bronze. The valve flanges are drilled according to EN 1092-2. Option: JIS B 2210 5K/10K and ANSI class 150.

FUNCTION

The slide is firmly connected with the motor spindle. When the slide is in the one outer position by turning the spindle, connection A-AB is fully open and connection B-AB is fully closed. In the other outer position connection A-AB is fully closed and connection B-AB is fully open.

In the intermediate positions the opening degrees change proportionally. The valve has a small tolerance between body and slide. PTFE sealing element and O-ring are mounted in the slider groove to minimize leakage.

This section to be read together with sketches page 2 this data sheet.

TECHNICAL DATA

Materials:	
- Valve body	Bronze CuSn10Zn2
- Slide	Alu. bronze CuAl10Fe5Ni5
- Sealing element and O-ring	Silicone/PTFE
Flow characteristic	Almost linear
Leakage rate	ANSI class IV/EN 1349 < 0.01%
Flanges	EN 1092-2 PN 10
- Option	JIS B 2210 5K/10K ANSI class 150
Max. pressure Δp , against which the valve can close	5 bar
Nominal pressure	PN 10
Design temperature	120°C
Optional temperature	150°C

FEATURES

- Simple design secures reliable controls and reduces costly downtime
- Ultra Low Leakage rate secures energy savings - Best in class
- Most compact valve on the market
- Full flexibility on port orientation
- Sea water resistant

Subject to change without notice.

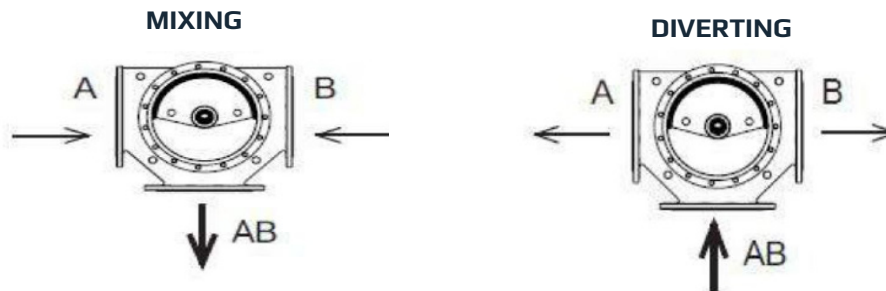
PORT NUMBERING: AB-MIDDLE**MOUNTING**

The valve connections are marked A, B and AB. The slide is operating between A and B. Check slide position before installation in the pipe. The slide position is marked on the top of the shaft. The valves can be installed with vertical as well as horizontal spindles. The valves must be mounted in a way that the valve actuator will be exposed to a minimum of moisture and unnecessary vibrations.

3-way Control Valve type L3FMT- ULLM Ultra Low Leakage (Middle)

Bronze, PN10, DN125 - DN 200 mm

0-2.6.22-A

Page 3 of 4

DIMENSION SKETCH

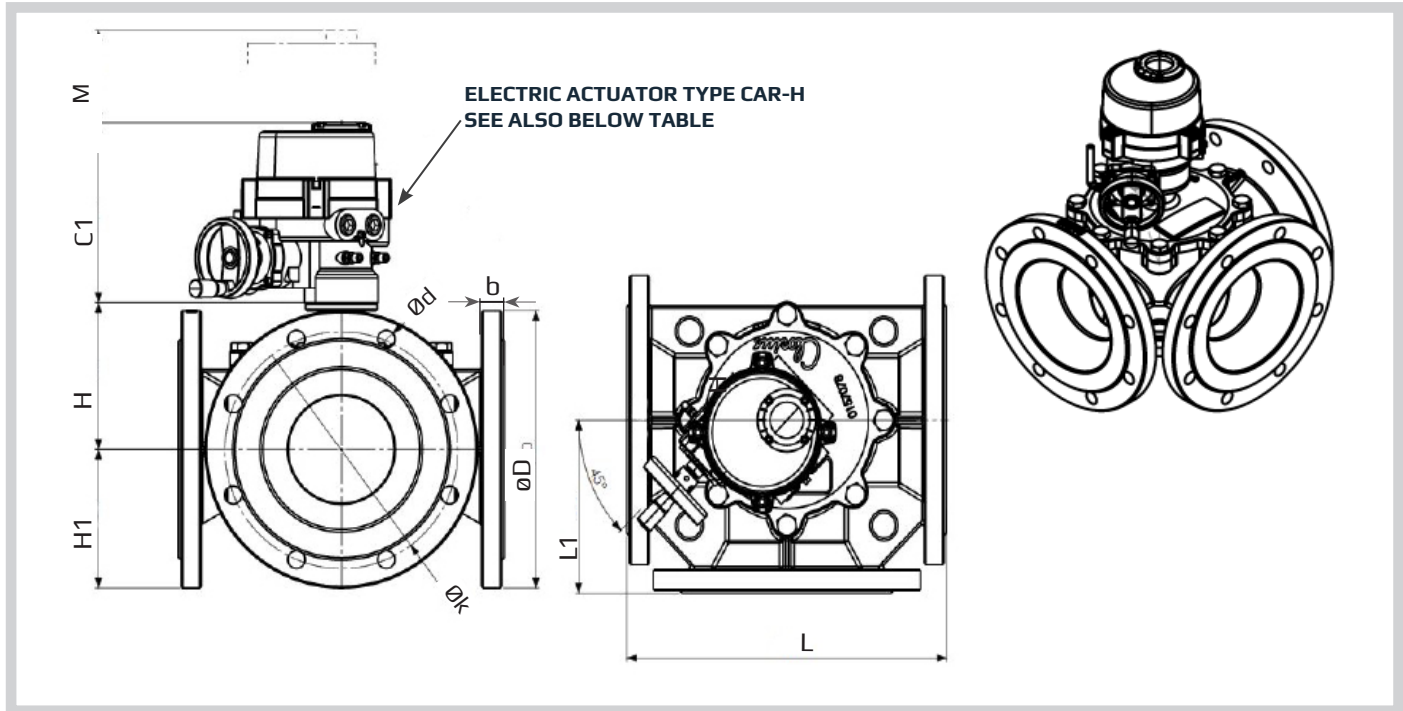

SPECIFICATIONS - TABLE 1 (read this together with table on page 4)

Type	L (mm)	L1 (mm)	H (mm)	H1 (mm)	b (mm)	C1 (mm)	M (mm)	Electric Actuator Type CAR-H
125 L3FMT-ULLM	330	165	140	ØD/2	24	223	110	CAR-H 006/010
125 L3FMT-ULLM JI55K	320	160	140	ØD/2	19	223	110	CAR-H 006/010
200 L3FMT-ULLM	410	205	182	ØD/2	28,4	261	150	CAR-H 016

ØD/2 - Depends on flange type (see also table 2)

SPECIFICATIONS
TABLE 2

Flange connections	EN 1092-2			ANSI Class 150			JIS B 2210 5K			JIS B 2210 10K		
	D (dia.) (mm)	k (dia.) (mm)	d mm dia. (number)	D (dia.) (mm)	k (dia.) (mm)	d mm dia. (number)	D (dia.) (mm)	k (dia.) (mm)	d mm dia. (number)	D (dia.) (mm)	k (dia.) (mm)	d mm dia. (number)
DN125	250	210	19x(8)	255	216	22x(8)	235	200	19x(8)	250	210	23x(8)
DN200	343	295	22x(8)	343	298	22x(8)	320	280	23x(8)	330	290	23x(12)

Torque calculated at max ΔP for: DN100 - 300 - 5 Bar

SPECIFICATIONS - TABLE 3

Type	Flange connection	KvS m ³ /h	Torque Nm	Weight kg
DN125	125	179	40	Pending
DN200	200	550	120	Pending

Torque calculated at max ΔP for: DN125 - 200 - 5 Bar

NOTE: KvS is max. KvS value

3-way Control Valve type L3FMT-SLM (Middle)

Bronze, PN10, DN125 - DN 200 mm - **coming soon**

0-2.6.24-A

Page 1 of 4

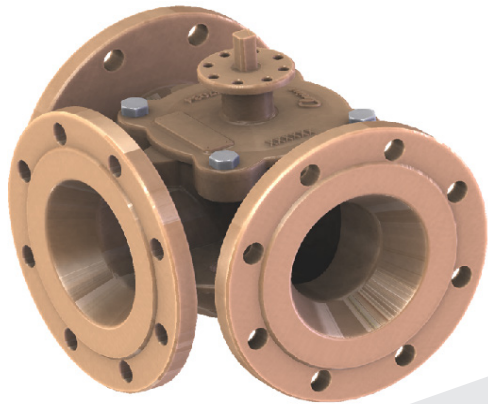

APPLICATIONS

Control valve type L3FMT-SLM is a three-way control valve with a slide for quarter turn operation designed for regulating of sea water, lubricating oil and other liquid media. The valves are designed for use in conjunction with industrial processes, district heating and marine installations with large water or lubricating oil volumes:

- Engine Jacket Cooling Water System
- Lubricating Oil Cooling
- Central Cooling Water System, etc.

The valves are designed for use in conjunction with electric actuator type CAR-H with handle for manual operation or for use in conjunction with a pneumatic actuator type VT.

DESIGN

The valve body is made of bronze and the slide is made of alu. bronze. The valve flanges are drilled according to EN 1092-2. Option: JIS B 2210 5K/10K and ANSI class 150

FUNCTION

The slide is firmly connected with the motor spindle. When the slide is in the one outer position by turning the spindle, connection A-AB is fully open and connection B-AB is fully closed. In the other outer position connection A-AB is fully closed and connection B-AB is fully open. In the intermediate positions the opening degrees change proportionally. The valve has a small tolerance between body and slide.

This section to be read together with sketches page 2 this data sheet.

TECHNICAL DATA

Materials:	
- Valve body	Bronze CuSn10Zn2
- Slide	Alu. bronze CuAl10Fe5Ni5
- O-ring	NBR
Flow characteristic	Almost linear
Leakage rate	ANSI class I
Flanges	EN 1092-2 PN 10
- Option	JIS B 2210 5K/10K ANSI class 150
Max. pressure Δp, against which the valve can close	5 bar
Nominal pressure	PN 10
Design temperature	120°C

FEATURES

- Simple design secures reliable controls and reduces costly downtime
- Most compact valve on the market
- Full flexibility on port orientation
- Sea water resistant

Subject to change without notice.

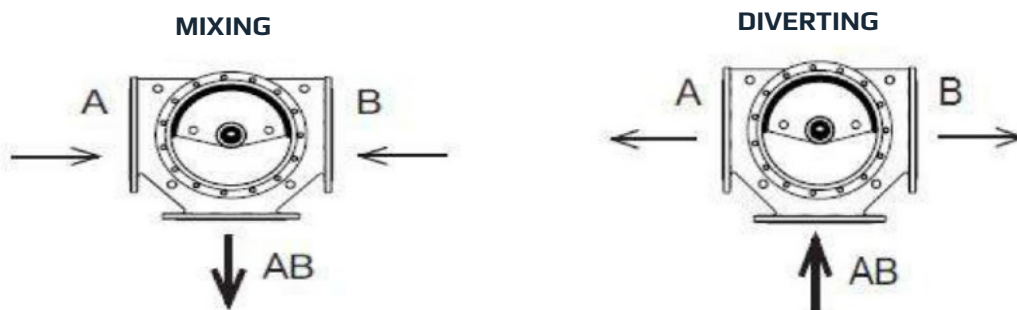
PORT NUMBERING: AB-MIDDLE**MOUNTING**

The valve connections are marked A, B and AB. The slide is operating between A and B. Check slide position before installation in the pipe. The slide position is marked on the top of the shaft. The valves can be installed with vertical as well as horizontal spindles. The valves must be mounted in a way that the valve actuator will be exposed to a minimum of moisture and unnecessary vibrations.

3-way Control Valve type L3FMT-SLM (Middle)

Bronze, PN10, DN125 - DN 200 mm **coming soon**

0-2.6.24-A

Page 3 of 4

DIMENSION SKETCH

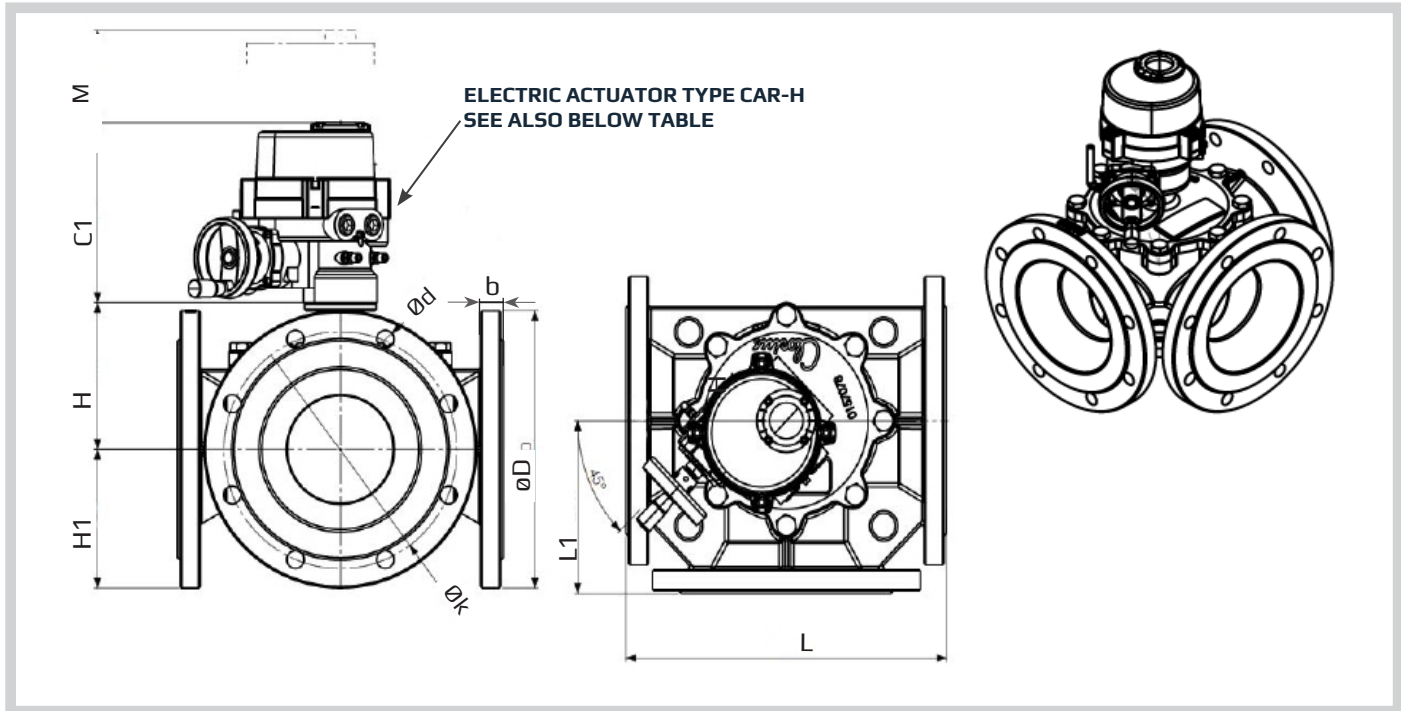

SPECIFICATIONS - TABLE 1 (read this together with table on page 4)

Type	L (mm)	L1 (mm)	H (mm)	H1 (mm)	b (mm)	C1 (mm)	M (mm)	Electric Actuator Type CAR-H
125 L3FMT-SLM	330	165	140	ØD/2	24	223	110	CAR-H 006
125 L3FMT-SLM (JIS5K)	320	160	140	ØD/2	19	223	110	CAR-H 006
200 L3FMT-SLM	410	205	182	ØD/2	28,4	223	110	CAR-H 010

ØD/2 - Depends on flange type (see also table 2)

**SPECIFICATIONS
 TABLE 2**

Flange connections	EN 1092-2			ANSI Class 150			JIS B 2210 5K			JIS B 2210 10K		
	D (dia.) (mm)	k (dia.) (mm)	d mm dia. (number)	D (dia.) (mm)	k (dia.) (mm)	d mm dia. (number)	D (dia.) (mm)	k (dia.) (mm)	d mm dia. (number)	D (dia.) (mm)	k (dia.) (mm)	d mm dia. (number)
DN125	250	210	19x(8)	255	216	22x(8)	235	200	19x(8)	250	210	23x(8)
DN200	343	295	22x(8)	343	298	22x(8)	320	280	23x(8)	330	290	23x(12)

1

SPECIFICATIONS - TABLE 3

Type	Flange connection	KvS m ³ /h	Torque Nm	Weight kg
DN125	125	179	40	Pending
DN200	200	550	90	Pending

Torque calculated at max ΔP for: DN125 - 200 - 5 Bar

****NOTE: KvS is max. KvS value**

2-way Control Valve type M1F

Nodular cast iron, PN 16, DN 15/4 – 50 mm

0-2.3.02-L

Page 1 of 2



TECHNICAL DATA

Materials:

- Valve body	Nodular cast iron EN-GJS-400-15
- Components	Stainless steel
- Bolts, nuts	24 CrMo 4/A4
- Gasket	Graphite
Nominal pressure	PN 16
Seating	Single-seated,
Flow characteristic	Quadratic
Leakage rate	$\leq 0,05\%$ of Kvs
Regulating capability	Kvs/Kvr > 25

Flanged ends
drilled according to EN 1092-2
PN 16

Counter flanges DIN 2633/BS 4504

APPLICATIONS

Control valves type M1F are designed for regulating low, medium and high pressure hot water, steam and lubricating oils. The valves are used in conjunction with our temperature or pressure differential regulators for controlling industrial processes, district or central heating plants or marine installations.

DESIGN

The valve components - spindle, seat and cone - are made of stainless steel. The valve body is made of nodular cast iron EN-GJS-400-15 with flanges drilled according to EN 1092-2. The thread for the actuator connection is G1B ISO 228. The valves are single-seated. The leakage rate is less than 0.05% of the full flow (according to VDI/VDE 2174).

FUNCTION

Without the actuator being connected, the valve is held in open position by means of a spring. With pressure on the spindle the valve will close. In connection with our thermostats, pneumatic or electronic actuators, the valves will close at rising temperatures. For cooling circuits the valve can be used in conjunction with a reverse acting electric actuator. Alternatively a reverse acting valve can be used with our self-acting thermostats. The quadratic characteristic will not cease until the flow has dropped below 4% of the full flow.

FEATURE

- Simple design secures reliable controls
- Location of the pack box in the actuator makes the valve service friendly
- Reliable and secure due to internal parts of stainless steel
- Low leakage rate reduces the risk of overheating

PRESSURE/TEMPERATURE DIAGRAM

According to DIN 2401

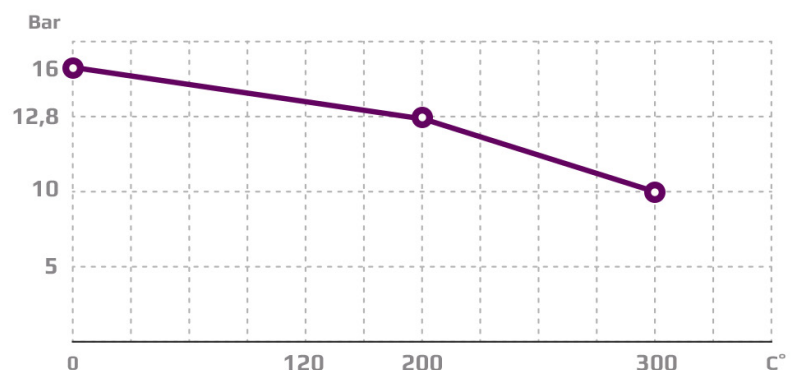

Subject to change without notice.

MOUNTING

The valve can be installed with vertical as well as horizontal spindles. For valve temperatures of max. 170 °C, the thermostat/ actuator can be fitted below or above the valve. For valve mounted with thermostats in media temperatures above 170 °C, a cooling unit has to be applied with connection downwards (please refer to data sheet for thermostat accessories). For electric actuators a high temperature adaptor must be used (please refer to datasheets for the electric actuators).



DIMENSION SKETCH

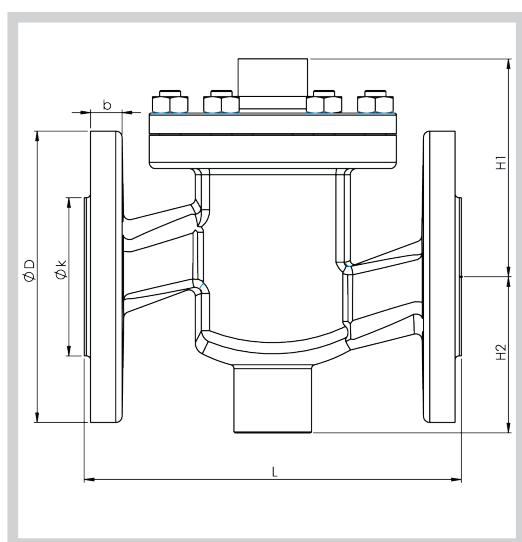

Type	L mm	H1 mm	H2 mm	b mm	D (dia.) mm	k (dia.) mm	d mm dia. (number)
15/4 M1F	130	80	60	14	95	65	14x(4)
15/6 M1F	130	80	60	14	95	65	14x(4)
15/9 M1F	130	80	60	14	95	65	14x(4)
15/12 M1F	130	80	60	14	95	65	14x(4)
15 M1F	130	80	60	14	95	65	14x(4)
20 M1F	150	85	65	16	105	75	14x(4)
25 M1F	160	95	70	16	115	85	14x(4)
32 M1F	180	105	75	18	140	100	14x(4)
40 M1F	200	110	85	18	150	110	14x(4)
50 M1F	230	125	95	20	165	125	14x(4)

SPECIFICATIONS

Type	Flange connection DN in mm	Opening mm	k_{vs} -value m ³ /h	Lifting height mm	Weight kg
15/4 M1F	15	4	0.20	6	3
15/6 M1F	15	6	0.45	6	3
15/9 M1F	15	9	0.95	6	3.1
15/12 M1F	15	12	1.70	6	3.1
15 M1F	15	15	2.75	6	3.1
20 M1F	20	20	5	6.5	4.2
25 M1F	25	25	7.50	7	5.5
32 M1F	32	32	12.50	8	8.1
40 M1F	40	40	20	9	9.7
50 M1F	50	50	30	10	14

Balanced 2-way Control Valve type M1FBN

Nodular cast iron, PN 16, DN 15 – 80 mm

0-2.3.03.01-F

Page 1 of 2



TECHNICAL DATA

Materials:

- Valve body	Nodular cast iron EN-GJS-400-15
- Components	Stainless steel
- Nuts, bolts	24 CrMo 5/A4
- O-ring	A.75H FEPM
- Gasket	Graphite
Nominal pressure	PN 16
Pressure balanced valve	
Seating	Single-seated, balanced
Flow characteristic	Quadratic
Leakage rate	$\leq 0.05\%$ of Kvs
Regulating capability	Kvs/Kvr > 25
Flanges drilled according to	EN 1092-2 or ANSI B16.5 Class 150

APPLICATIONS

Balanced control valves type M1FBN are designed for regulating hot water, steam and hot oil systems. Balanced valves are used in installations where the system pressure necessitates a closing force greater than available in the actuator programme for a standard single seated valve, and where the leakage rate for a double-seated valve is unacceptable. The valves are used in conjunction with our temperature or pressure differential regulators for controlling industrial processes, district or central heating plants or marine installations.

DESIGN

The valve components, spindle, seat and cone - are made of stainless steel. The valve body is made of nodular cast iron EN-GJS-400-15 with flanges drilled according to EN 1092-2 or ANSI B16.5 Class 150. The thread for the actuator connection is G1B ISO 228. The valves are single-seated. The leakage rate is less than 0.05% of the full flow (according to VDI/VDE 2174).

FUNCTION

Without an actuator being connected, the valve is held in open position by means of a spring. With force on the spindle the valve will close. In connection with our thermostats, pneumatic or electric actuators, the valves will close at rising temperatures. For cooling circuits the valve can be used in conjunction with a reverse acting electric actuator. The quadratic characteristic will not cease until the flow has dropped below 4% of the full flow.

FEATURES

- Simple design secures reliable controls
- Location of the pack box in the actuator makes the valve service friendly
- Reliable and secure due to internal parts of stainless steel
- Low leakage rate reduces the risk of overheating

PRESSURE/TEMPERATURE DIAGRAM

According to DIN 2401

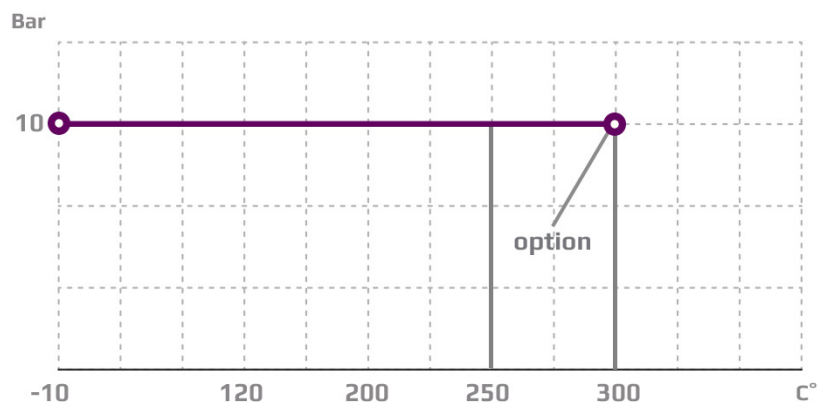

Subject to change without notice.

MOUNTING

The valve can be installed with vertical as well as horizontal spindles. For valve temperatures of max. 170 °C, the thermostat/ actuator can be fitted below or above the valve. For valve mounted with thermostats in media temperatures above 170 °C, a cooling unit has to be applied with connection downwards (please refer to data sheet for thermostat accessories). For electric actuators a high temperature adaptor must be used (please refer to data sheets for the electric actuators).

DIMENSION SKETCH

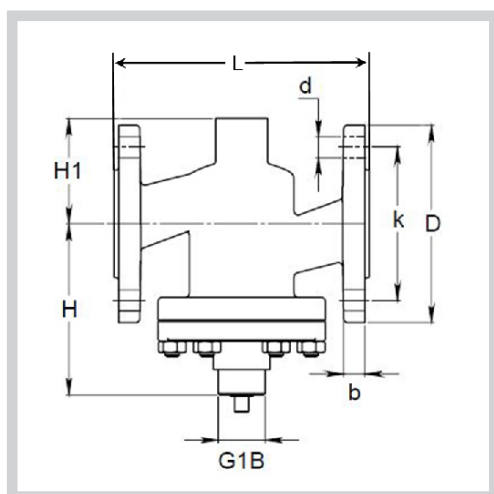

Type	L mm	H mm	H1 mm	D (dia.) mm	b mm	k (dia.) mm	d mm dia. (number)
15 M1FBN	130	101	80	95	14	65	14x(4)
20 M1FBN	150	107	85	105	16	75	14x(4)
25 M1FBN	160	112	70	115	16	85	14x(4)
32 M1FBN	180	122	75	140	18	100	18x(4)
40 M1FBN	200	125	85	150	19	110	18x(4)
50 M1FBN	230	140	95	165	19	125	18x(4)
65 M1FBN	290	154	110	185	19	145	18x(4)
80 M1FBN	310	164	115	200	19	160	19x(8)

SPECIFICATIONS

Type	Flange connection DN in mm	Opening mm	k_{vs} -value m ³ /h	Lifting height mm	Weight kg
15 M1FBN	15	15	4	7.5	4
20 M1FBN	20	20	6.3	7.5	5
25 M1FBN	25	25	10	9	6
32 M1FBN	32	32	16	10	9
40 M1FBN	40	40	25	11	13
50 M1FBN	50	50	35	11.5	16
65 M1FBN	65	65	58	14.5	23
80 M1FBN	80	80	80	16	38

2-way Control Valve type M2F,

Nodular cast iron, PN 16, DN 20 – 80 mm, 2 seats, Flanged ends

0-2.3.04-N

Page 1 of 2



TECHNICAL DATA

Materials:

- Valve body	Nodular cast iron EN-GJS-400-15
- Spring	1.4568
- Cone	1.4408, 1.4305
- Gasket	Stainless steel foil and graphite
- Upper seat	AISI 303
- Lower seat	1.4301, 1.4305, 1.4307
- Bolts, nuts	24 CrMo 4/A4
Nominal pressure	PN 16
Seating	Double-seated
Flow characteristic	Quadratic
Leakage rate	≤ 0,5% of Kvs
Regulating capability	Kvs/Kvr > 25

Flanges drilled

according to	EN 1092-2 PN 16
Counter flanges	DIN 2633/BS 4504
Adjustable seat interspace	

Subject to change without notice.

APPLICATIONS

Control valves type M2F are designed for regulating hot water, steam and lubricating oil systems. The double-seated valves are used in installations where the system pressure necessitates a closing force greater than available in the actuator programme for a single-seated valve. The valves are used in conjunction with our temperature or pressure differential regulators for controlling industrial processes, district or central heating plants or marine installations.

DESIGN

The valve components - spindle, seats and cone - are made of stainless steel. The valve body is made of nodular cast iron EN-GJS-400-15 with flanges drilled according to EN 1092-2. The thread for the actuator connection is G1B ISO 228. The valves are double-seated. The leakage rate is less than 0.5% of the full flow (according to VDI/VDE 2174).

FUNCTION

Without the actuator being connected, the valve is held in open position by means of a spring. With pressure on the spindle the valve will close. In connection with our thermostats or electronic actuators, the valves will close at rising temperatures. For cooling circuits the valve can be used in conjunction with a reverse acting electric actuator. Alternatively a reverse acting valve can be used with our self-acting thermostats. The quadratic characteristic will not cease, until the flow has dropped below 4% of the full flow.

FEATURES

- Simple design secures reliable controls.
- Location of the pack box in the actuator makes the valve service friendly
- Reliable and secure due to internal parts of stainless steel

PRESSURE/TEMPERATURE DIAGRAM

According to DIN 2401

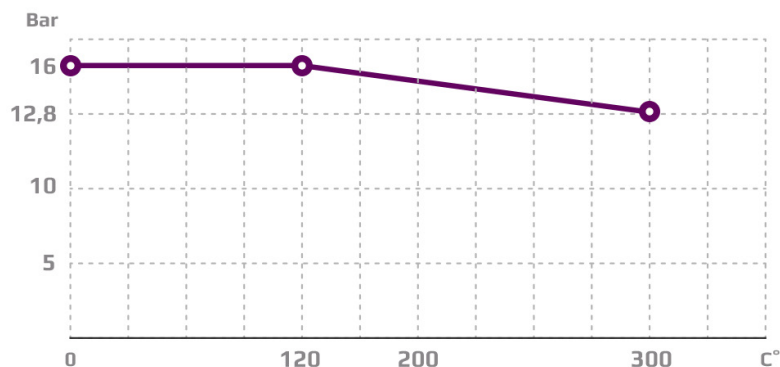

MOUNTING

The valve can be installed with vertical as well as horizontal spindles. For valve temperatures of max. 170 °C, the thermostat/ actuator can be fitted below or above the valve. For valve mounted with thermostats in media temperatures above 170 °C, a cooling unit has to be applied with connection downwards (please refer to data sheet for thermostat accessories). For electric actuators a high temperature adaptor must be used (please refer to data sheets for the electric actuators).

DIMENSION SKETCH

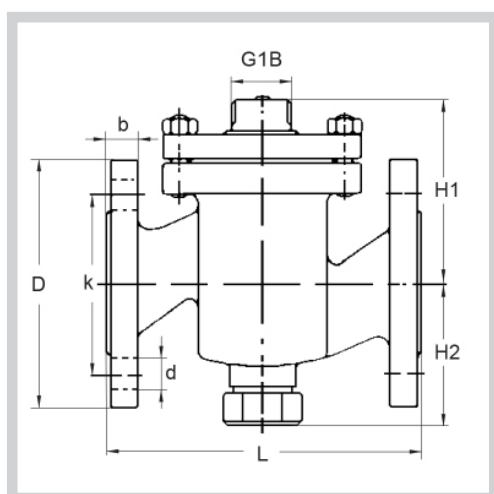

Type	L mm	H1 mm	H2 mm	b mm	D (dia.) mm	k (dia.) mm	d mm dia. (number)
20 M2F	150	85	70	16	105	75	14x(4)
25 M2F	160	95	77	16	115	85	14x(4)
32 M2F	180	105	82	18	140	100	19x(4)
40 M2F	200	110	92	19	150	110	19x(4)
50 M2F	230	125	102	19	165	125	19x(4)
65 M2F	290	135	120	19	185	145	19x(4)
80 M2F	310	145	130	19	200	160	19x(8)

SPECIFICATIONS

Type	Flange connection DN in mm	Opening mm	k_{vs} -value m ³ /h	Lifting height mm	Weight kg
20 M2F	20	20	5	6.5	5
25 M2F	25	25	7.5	7	6.5
32 M2F	32	32	12.5	8	9
40 M2F	40	40	20	9	11
50 M2F	50	50	30	10	16
65 M2F	65	65	50	11	21
80 M2F	80	80	80	13	38

2-way Control Valve type M2F

Nodular cast iron, PN 16, DN 100 – 150 mm

0-2.3.05-H

Page 1 of 2



TECHNICAL DATA

Materials:

- Valve body	Nodular cast iron EN-GJS-400-15
- Components	Stainless steel
- Nuts, bolts	24 CrMo 4/A4
- Gasket	Graphite
Nominal pressure	PN 16
Seating	Double-seated
Flow characteristic	Almost quadratic
Function	Closing with pressure on spindle
Leakage rate	$\leq 0,5\%$ of Kvs
Regulating capability	Kvs/Kvr > 25

Flanges drilled according to	EN 1092-2
Counter flanges	DIN 2633

APPLICATIONS

Control valves type M2F are designed for regulating hot water, steam and hot oil systems. The valves are installed combined with temperature or pressure differential regulators in control systems for heating to domestic premises, district and group heating schemes, industrial processes or marine installations.

DESIGN

The valve components - spindle, seats and cone - are made of stainless steel. The valve body is made of nodular cast iron EN-GJS-400-15 with flanges drilled according to EN 1092-2. The connection thread for the actuator connection is G1B ISO 228. The valves are double-seated. The leakage rate is less than 0.5% of the full flow (according to VDI/VDE 2174).

FUNCTION

Without the actuator being connected, the valve is held in open position by means of a spring. With pressure on the spindle the valve will close. In connection with our thermostats, pneumatic or electric actuators, the valves will close at rising temperatures. For cooling circuits the valve can be used in conjunction with a reverse acting electric actuator. Alternatively a reverse acting valve can be used with our self-acting thermostats. The linear characteristic will not cease, until the flow has dropped below 4% of the full flow.

FEATURES

- Simple design secures reliable controls
- Location of the pack box in the actuator makes the valve service friendly
- Reliable and secure due to internal parts of stainless steel

PRESSURE/TEMPERATURE DIAGRAM

According to DIN 2401

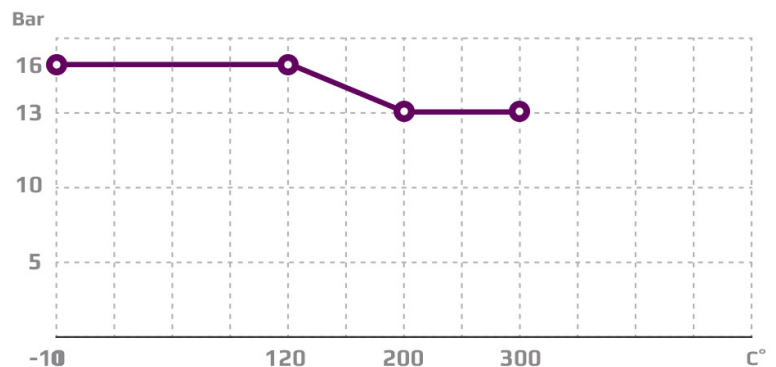

Subject to change without notice.

MOUNTING

The valve can be installed with vertical as well as horizontal spindles. For valve temperatures of max. 170 °C, the thermostat/ actuator can be fitted below or above the valve. For valve mounted with thermostats in media temperatures above 170 °C, a cooling unit has to be applied with connection downwards (please refer to data sheet for thermostat accessories). For electric actuators a high temperature adaptor must be used (please refer to data sheets for the electric actuators).

DIMENSION SKETCH

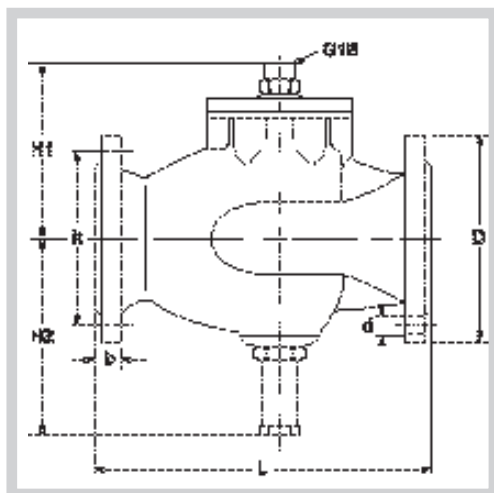

Type	L mm	H1 mm	H2 mm	b mm	D (dia.) mm	k (dia.) mm	d mm dia. (number)
100 M2F	350	185	209	24	220	180	18x(8)
125 M2F	400	205	224	26	250	210	18x(8)
150 M2F	400	240	244	26	285	240	22x(8)

SPECIFICATIONS

Type	Flange connection DN in mm	Opening mm	k_{vs} -value m^3/h	Lifting height mm	Weight kg
100 M2F	100	100	125	20	32
125 M2F	125	125	215	20	50
150 M2F	150	150	310	20	70



2-way Control Valve type M2FA,

Nodular cast Iron, PN 10, DN 200 mm / PN 6, DN 250 – 300 mm

0-2.3.05.01-B

Page 1 of 2



APPLICATIONS

Regulating valve type M2FA is designed for regulating water, lubricating oil and other liquid media. The valves are designed for use in conjunction with large industrial processes, district heating and marine installations, e.g. cooling of main and auxiliary engines. Is designed for use in conjunction with Clorius valve motor type AVM/AVF 234.

DESIGN

The valve components (seats and cone) are made of alu bronze, the spindle of stainless steel. The valve body is made of nodular cast iron and the valve flanges are drilled according to EN 1092-2.

FUNCTION

The valve cone is firmly connected with the motor spindle. The valve will close or open at rising temperatures. Depending on the application a reverse acting actuator can be used. The linear characteristic will not cease, until the flow has dropped below 4% of the full flow.

TECHNICAL DATA

Materials:

- Valve body	Nodular cast iron EN-GJS-400-15
- Trim	Alu Bronze CuAL10Fe5Ni5
- Valve spindle	Stainless steel (W.no. 1.4436)
- O-ring	AFLAS A75H
- Gasket	Reinz-AFM34

Nominal pressure

- 200 M2FA	PN 10 (max. 120°C)
- 250-300 M2FA	PN 6 (max. 120°C)

Seating Double-seated

Flow characteristic Almost linear

Leakage rate $\leq 0.5\%$ of Kvs

Regulating capability Kvs/Kvr > 25

Flanges EN 1092-2 PN 10

Note!

Type 250 M2FA has outer measures and flanges drilled as type 300 M2FA

Counter flanges (suggested)

- 200 M2FA	DIN 2633 – PN 10/16
- 250-300 M2FA	DIN 2632 – PN 10

FEATURES

- Simple design secures reliable controls and reduces costly downtime
- Location of the pack box in the actuator makes the valve service friendly
- Reliable and secure due to internal parts of stainless steel

PRESSURE/TEMPERATURE DIAGRAM

According to DIN 2401

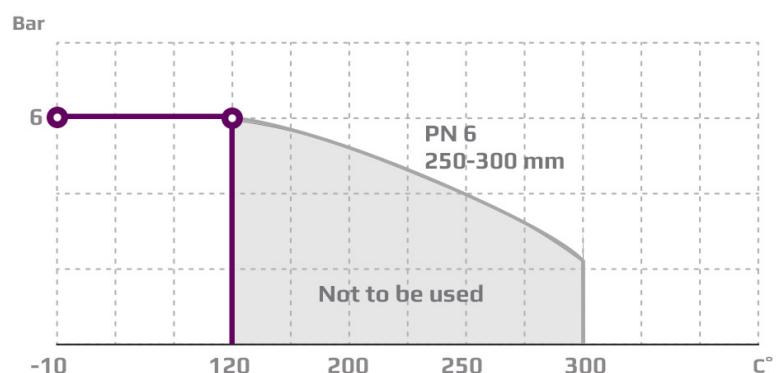
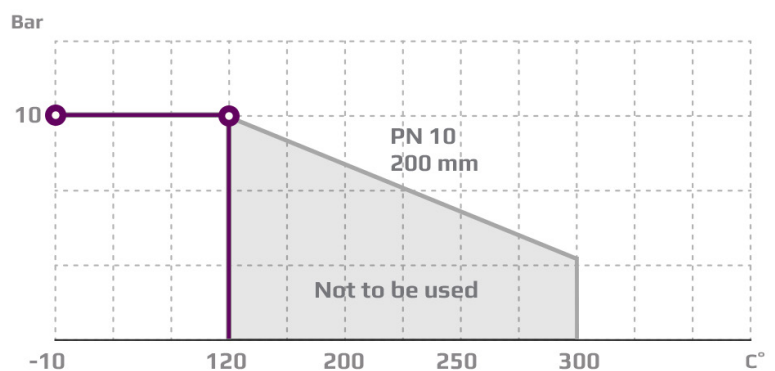

Subject to change without notice.

PORT NUMBERING

The ports of valves type M2FA are marked with the figures 1 and 2. The letters in parentheses refer to the corresponding internationally adapted designations.

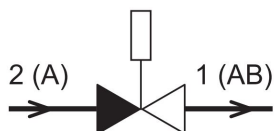

Port 2(A) closes at load on spindle.

MOUNTING

The valves can be installed with vertical as well as horizontal spindles. The valves must be mounted in a way that the valve motor will be exposed to a minimum of moisture and unnecessary vibrations. Free height above / below the valve must be minimum 400 mm for mounting and operation of the AFM 234 or AVF234 motor. See drawing.

DIMENSION SKETCH

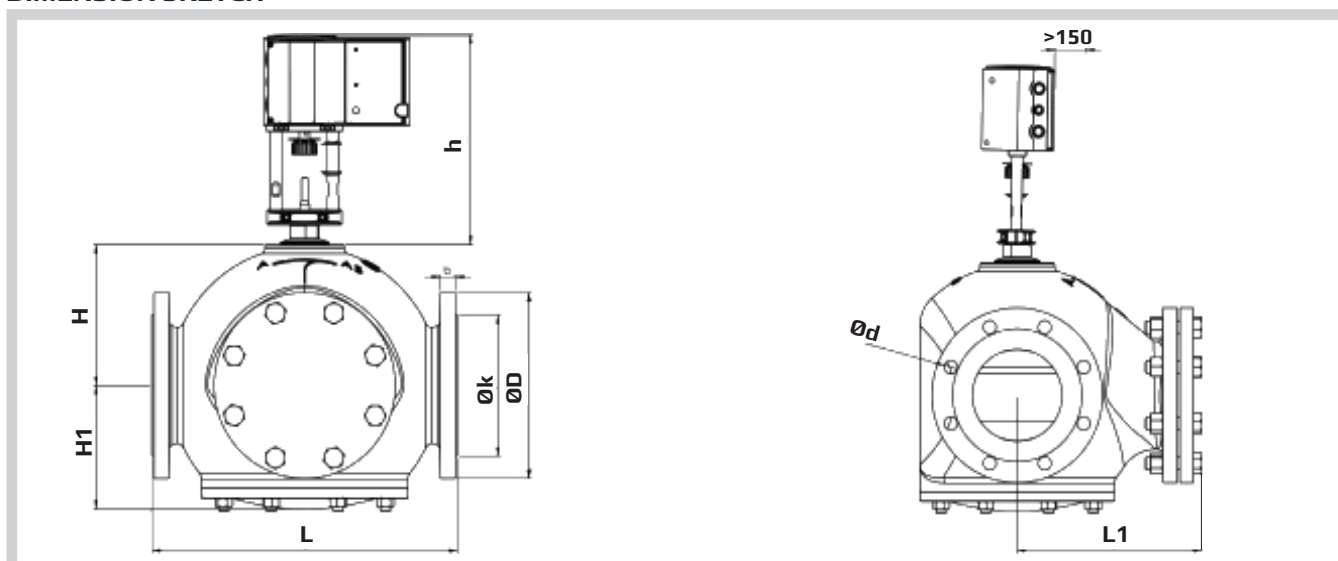

Type	L mm	L1 mm	H mm	H1 mm	b mm	D (dia.) mm	k (dia.) mm	d mm dia. (number)
200 M2FA	600	380	238	238	26	340	295	22x(8)
250 M2FA ¹⁾	850	510	305	305	28	445	400	23x(12)
300 M2FA	850	510	305	305	28	445	400	23x(12)

1) Valve type 250 M2FA has outer measures and flanges drilled as type 300 M2FA.

SPECIFICATIONS

Type	Flange connection mm	Opening DN in mm	k_{vs} -value m^3/h	Lifting height mm	Weight kg
200 M2FA	200	200	555	28	160
250 M2FA ¹⁾	300	300	865	28	306
300 M2FA	300	300	1250	45	290

1) Valve type 250 M2FA has outer measures and flanges drilled as type 300 M2FA.

2-way Control Valve type M2FR

Nodular cast iron, PN 16, DN 20 – 80 mm, 2 seats, Reverse acting

0-2.3.06-N

Page 1 of 2

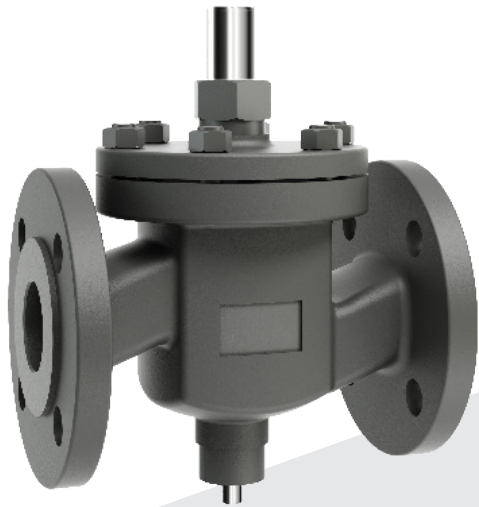

TECHNICAL DATA

Materials:

- Valve body	Nodular cast iron EN-GJS-400-15
- Trim	Stainless steel
- Nuts, bolts	24 CrMo 4/A4
- Gasket	Graphite
Nominal pressure	PN 16
Seating	Double-seated
Flow characteristic	Quadratic
Function	Opens by pressing the spindle
Leakage rate	≤ 0,5% of Kvs
Regulating capability	Kvs/Kvr > 25
Flanges drilled according to	EN 1092-2
Counter flanges	DIN 2633/BS 4504

Reverse acting (normally closed)
For cooling systems or similar
Adjustable seats

Subject to change without notice.

APPLICATIONS

Valves type M2FR are mainly intended for control of cooling systems. The valves are used in conjunction with temperature or pressure differential regulators for controlling industrial processes or cooling systems. As the reverse acting valves are held in closed position by means of a built-in spring, the max. differential pressure, Δp_L , against which a valve can close depends on the spring and when opening the valve, the actuator has to overcome the spring force. The table on the next page shows the max. allowable values of Δp_L as well as the max. allowable inlet pressures for opening the valves, p_{1max} , for various actuator forces.

DESIGN

The valve components - spindle, seats and cone - are made of stainless steel. The valve body is made of nodular cast iron EN-GJS-400-15 with flanges drilled according to EN 1092-2. The thread for the actuator connection is G1B ISO 228. The valves are double-seated. The leakage rate is less than 0.5% of the full flow (according to VDI/VDE 2174).

FUNCTION REVERSE ACTING

Without an actuator being connected, the valve is held in closed position by means of a spring. With pressure on the spindle the valve opens. In connection with our actuators, the valves act as "cooling" valves, i.e. they open at rising temperatures. The quadratic characteristic will not cease until the flow has dropped below 4% of the full flow.

FEATURES

- Simple design secures reliable controls.
- Location of the pack box in the actuator makes the valve service friendly
- Reliable and secure due to internal parts of stainless steel

PRESSURE/TEMPERATURE DIAGRAM

According to DIN 2401

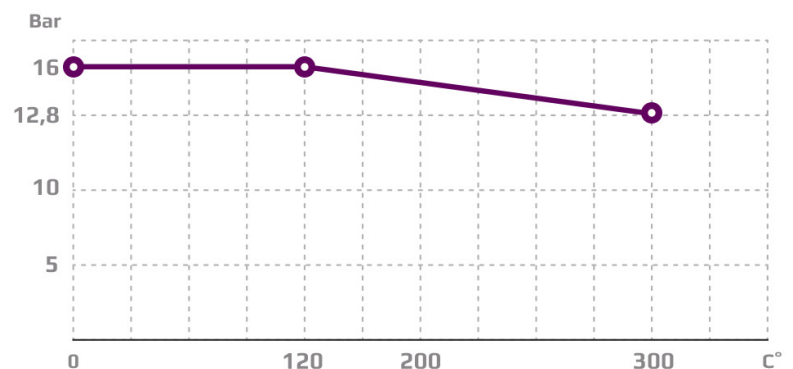

MOUNTING

The valve can be installed with vertical as well as horizontal spindles. For valve temperatures of max. 170 °C, the thermostat/ actuator can be fitted below or above the valve. For valve mounted with thermostats in media temperatures above 170 °C, a cooling unit has to be applied with connection downwards (please refer to data sheet for thermostat accessories). For electric actuators a high temperature adaptor must be used (please refer to data-sheets for the electric actuators).

DIMENSION SKETCH

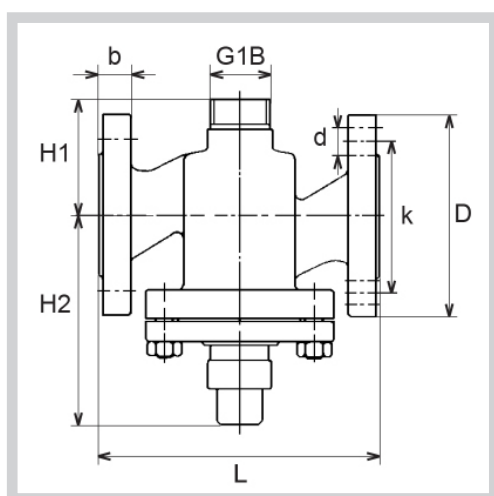

Type	L mm	H1 mm	H2 mm	D (dia.) mm	b mm	k (dia.) mm	d mm dia. (number)
20 M2FR	150	63	112	105	16	75	14x(4)
25 M2FR	160	70	117	115	16	85	14x(4)
32 M2FR	180	75	151	140	18	100	19x(4)
40 M2FR	200	85	155	150	19	110	19x(4)
50 M2FR	230	95	169	165	19	125	19x(4)
65 M2FR	290	110	180	185	19	145	19x(4)
80 M2FR	310	120	180	200	19	160	19x(8)

SPECIFICATIONS

Type	Flange connection Dn in mm	Opening mm	k_{vs} -value m ³ /h	Lifting height mm	Max. Δp_L bar	Actuat. force N	Corresp. p_{1max} bar	Weight kg
20 M2FR	20	20	5	6.5	8.3	200 400	9.4 16	5
25 M2FR	25	25	7.5	7	8	200 400	8.8 16	6.5
32 M2FR	32	32	12.5	8	7	400	16	9
40 M2FR	40	40	20	9	6.6	400	16	11
50 M2FR	50	50	30	10	5.8	400	15	16
65 M2FR	65	65	50	11	10	400 800	10 16	21
80 M2FR	80	80	80	13	6.7	400 800	10 16	38

2-way Control Valve type M2FR

Nodular cast iron, PN 16, DN 100 – 150 mm, Reverse acting

0-2.3.07-I

Page 1 of 2



APPLICATIONS

Valve type M2FR are mainly intended for control of cooling systems. The valves are used in conjunction with temperature or pressure differential regulators. As the reverse acting valves are held in closed position by means of a built-in spring, the max. differential pressure, Δp_L , against which a valve can close depends on the spring and when opening the valve, the actuator has to overcome the spring force. On the next page please find the max. allowable values of Δp_L as well as the max. allowable inlet pressures for opening the valve, $p_{1_{max}}$ for various actuator forces.

DESIGN

The valve components - spindle, seats and cone - are made of stainless steel. The valve body is made of nodular cast iron EN-GJL-250 with flanges drilled according to EN 1092-2. The connection thread for the actuator is G1B ISO 228. The valves are double-seated. The leakage rate is less than 0.5% of the full flow (according to VDI/VDE 2174).

FUNCTION REVERSE ACTING

Without an actuator being connected, the valve is held in closed position by means of a spring. With pressure on the spindle the valve opens. In connection with our thermostats, the valves act as "cooling" valves, i.e. they open at rising temperatures. The linear characteristic will not cease until the flow has dropped below 4% of the full flow.

TECHNICAL DATA

Materials:	
- Valve body	Nodular cast iron EN-GJS-400-15
- Trim	Stainless steel
- Nuts, bolts	24 CrMo 4/A4
- Gasket	Graphite
Nominal pressure	PN 16
Seating	Double-seated
Flow characteristic	Quadratic
Function	Opening with pressure on spindle
Leakage rate	$\leq 0,5\%$ of Kvs
Regulating capability	Kvs/Kvr > 25
Flanges	EN 1092-2 PN 16
Counter flanges	DIN 2633 / DS623

Reverse acting (normally closed)
For cooling water and lubrications

FEATURES

- Simple design secures reliable controls
- Location of the pack box in the actuator makes the valve service friendly
- Reliable and secure due to internal parts of stainless steel

PRESSURE/TEMPERATURE DIAGRAM

According to DIN 2401

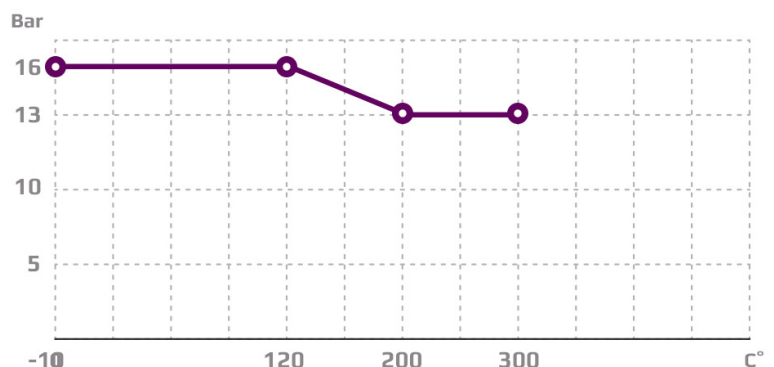

Subject to change without notice.



MOUNTING

The valve can be installed with vertical as well as horizontal spindles. For valve temperatures of max. 170 °C, the thermostat/ actuator can be fitted below or above the valve. For valve mounted with thermostats in media temperatures above 170 °C, a cooling unit has to be applied with connection downwards (please refer to data sheet for thermostat accessories). For electric actuators a high temperature adaptor must be used (please refer to data-sheets for the electric actuators).

DIMENSION SKETCH

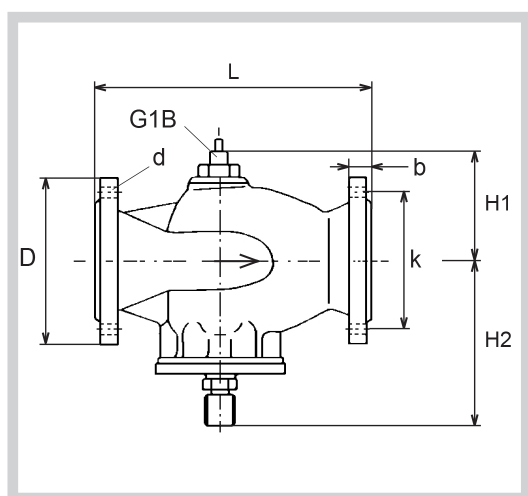

Type	L mm	H1 mm	H2 mm	D (dia.) mm	b mm	k (dia.) mm	d mm dia. (number)
100 M2FR	350	145	240	220	24	180	18x(8)
125 M2FR	400	160	260	250	26	210	18x(8)
150 M2FR	400	180	293	285	26	240	22x(8)

SPECIFICATIONS

Type	Flange connection Dn in mm	Opening mm	k_{vs} -value m ³ /h	Lifting height mm	Max. Δp_L bar	Actuat. force N	Weight kg
100 M2FR	100	100	125	20	12.1	800	39
125 M2FR	125	125	215	20	9	800	53
150 M2FR	150	150	310	20	7.5	800	73

3-way control valve type M3F

Nodular cast iron, PN 16, DN 20 – 65 mm, Flanged ends

0-2.3.08-K

Page 1 of 2

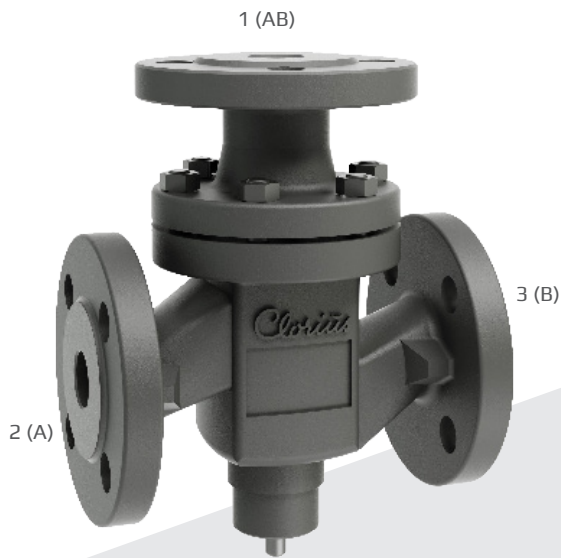

TECHNICAL DATA

Materials:

- Valve body	Nodular cast iron EN-GJS-400-15
- Seats, cone & spindle	Stainless steel
- Bolts, nuts	Stainless steel A4
- Gasket	Graphite
- O-ring	FPM

Nominal pressure	PN 16
Seating	2 balanced single seats
Flow characteristic	Quadratic/linear
Leakage rate	≤ 0,5% of Kvs
Regulating capability	Kvs/Kvr > 25
Flanges - drilled according to	EN 1092-2 PN 16
Counter flanges	DIN 2633

Same Kvs-value as mixing and diverting valve
Ideal for controlling process and central
heating plants

Subject to change without notice.

APPLICATIONS

Control valves type M3F are designed for lubricants, hot water and other liquids and can be installed in pipe systems as mixing or diverting valves. The valves are used in conjunction with our temperature regulators for controlling industrial processes, district or central heating plants or marine installations.

DESIGN

The valve components - seats, cone and spindle are made of stainless steel. The valve body is made of nodular cast iron EN-GJS-400 -15 with flanges drilled according to EN 1092-2 PN 16. The thread for the actuator connection is G1B ISO 228. The valves have two balanced single seats. The leakage rate is less than 0.5 % of the full flow (according to VDI/VDE 2174).

FUNCTION

Without an actuator being installed, connection A-AB is fully open and connection B-AB completely closed by means of a spring.

By increasing pressure on the spindle, the opening of the ports changes proportionally to the travel of the spindle, and when the spindle is pressed to the bottom, connection B-AB is fully open and connection A-AB completely closed.

The valve characteristics are as follows:

Port A-AB and AB-A: quadratic

Port B-AB and AB-B: almost linear

These characteristics ensure constant total flow under almost all pressure conditions and optimum circulation in the individual circuits.

FEATURES

- Can be used for both mixing and diverting
- Simple design secures reliable controls and reduces costly downtime
- Location of the pack box in the actuator makes the valve service friendly

PRESSURE/TEMPERATURE DIAGRAM

According to DIN 2401

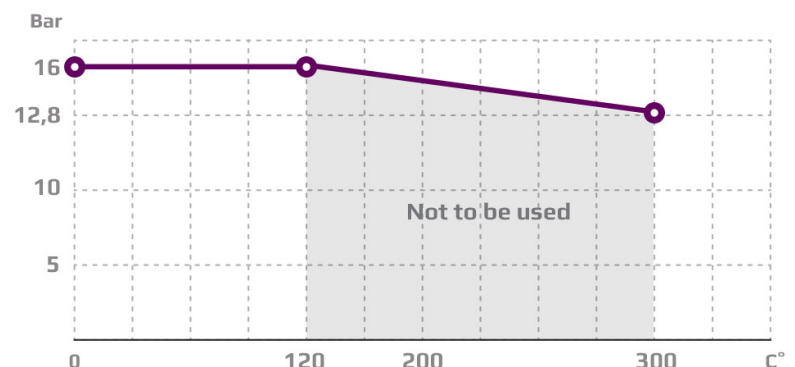

PORT NUMBERING

Valves type M3F are marked with the internationally recognized port designations: A, B, AB

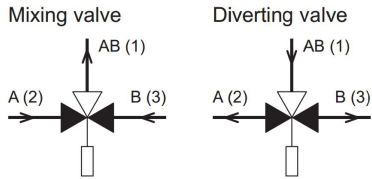

Port AB
Port A
Port B

common port always open
closes by activating the spindle
opens by activating the spindle



MOUNTING

The valves can be installed with vertical as well as horizontal spindles.

DIMENSION SKETCH

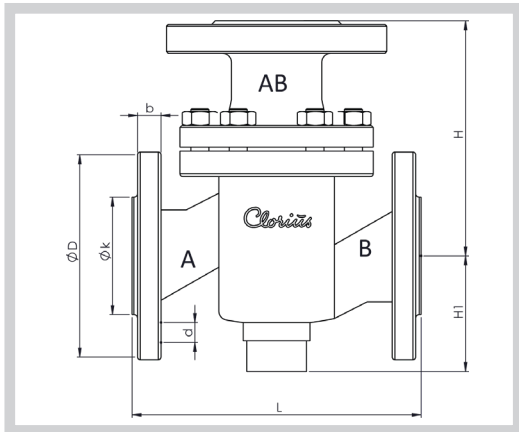

Type	L mm	H mm	H1 mm	D (dia.) mm	b mm	k (dia.) mm	d mm dia. (number)
20 M3F	150	115	63	105	16	75	14x(4)
25 M3F	160	130	70	115	16	85	14x(4)
32 M3F	180	150	75	140	18	100	18x(4)
40 M3F	200	160	85	150	18	110	18x(4)
50 M3F	230	190	95	165	20	125	18x(4)
65 M3F	290	220	110	185	20	145	18x(4)

SPECIFICATIONS

Type	Flange connection DN in mm	Opening mm	k _{vs} -value* m ³ /h	Lifting height mm	Weight kg
20 M3F	20	20	6.3	7.5	6
25 M3F	25	25	10	9	7
32 M3F	32	32	16	10	10
40 M3F	40	40	25	11	14
50 M3F	50	50	38	11.5	18
65 M3F	65	65	63	14.5	26

*Same kvs-values for mixing and diverting valves

3-way Control Valve type M3F

Nodular cast iron, PN 10, DN 80 – 150 mm

0-2.3.09-K

Page 1 of 2

APPLICATIONS

Control valves type M3F are designed for regulating of water, lubricating oil and other liquid media and can be mounted in the pipe system as either mixing or diverting valves. However when mounting as a diverting valve the pressure drop is increased, compared with mounting as a mixing valve. See "Important note" under Technical Data. The valves are used in conjunction with our temperature regulators for controlling industrial processes, district and central heating plants and marine installations.

DESIGN

The valve components - seats and cone are made of alu-bronze, the spindle is made of stainless steel. The valve body is made of nodular cast iron EN-GJS-400-15 with flanges drilled according to EN 1092-2. The connection thread for the actuator is G1B ISO 228. The valves have two balanced single seats. The leakage rate is less than 0.5% of the full flow (according to VDI/VDE 2174). Tight between port 1(AB) og 3(B) is optional.

FUNCTION

Without an actuator being installed, connection A-AB is fully open and connection B-AB completely closed, by means of a spring. By increasing pressure on the spindle, the opening of the ports changes proportionally to the travel of the spindle, and when the spindle is pressed to the bottom, connection B-AB is fully open and connection A-AB completely closed.

FEATURES

- Can be used for both mixing and diverting
- Simple design secures reliable controls and reduces costly downtime
- Location of the pack box in the actuator makes the valve service friendly

PRESSURE/TEMPERATURE DIAGRAM

According to DIN 2401

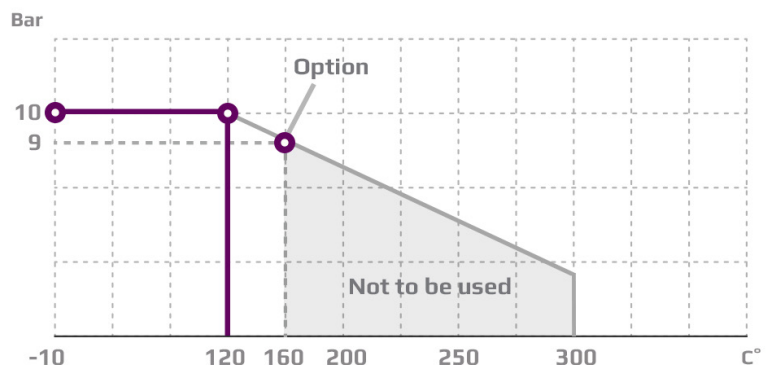

TECHNICAL DATA

Materials:

- Valve body	Nodular cast iron EN-GJS-400-15
- Seats and cone	Alu-Bronze
- Spindle	Stainless steel
- O-ring	NBR
- Gasket	Reinz-AFM34

Seating	Two balanced single seats
---------	------------------------------

Flow characteristic	Almost linear
Leakage rate	≤ 0.5% of Kvs
Regulating capability	Kvs/Kvr > 25

Flanges drilled according to	EN 1092-2 PN 10
Counter flanges	DIN 2632
Nominal pressure	PN 10 (10 bar/max 120°C option 9 bar/max 160 °C)

For regulating of process and central heating plants

Important note

In case the valves are applied as diverting valves, the pressure drop will increase by 35% and the kvs-value will decrease by 14% as against mixing valves.

Subject to change without notice.

PORT NUMBERING

The ports of valves type M3F are marked with the letters AB, A and B.

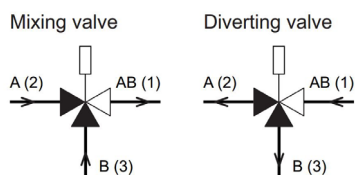

Port AB(1)
Port A(2)
Port B(3)

common port always open
closes at load on spindle
opens at load on spindle

MOUNTING

The valve can be installed with vertical as well as horizontal spindles. The valve must be mounted in a way that the valve actuator will be exposed to a minimum of moisture and unnecessary vibrations.

DIMENSION SKETCH

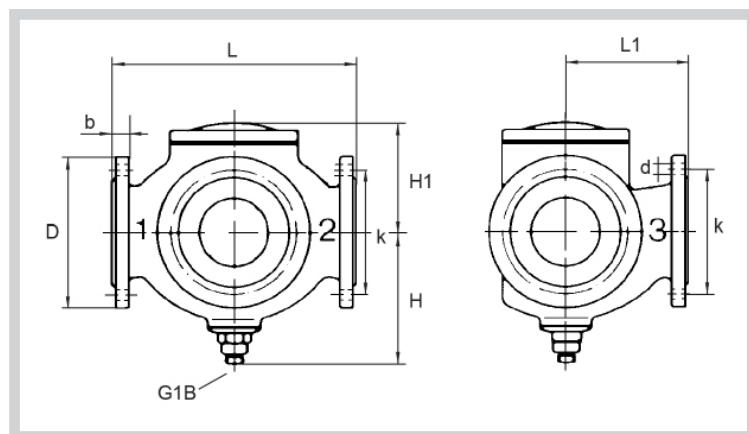

Type	L mm	L1 mm	H mm	H1 mm	D (dia.) mm	b mm	k (dia.) mm	d mm dia. (number)
80 M3F	310	155	180	127	200	20	160	18x(8)
100 M3F	350	175	195	141	220	22	180	18x(8)
125 M3F	400	240	245	171	250	21	210	19x(8)
150 M3F	480	270	280	189	285	22	240	22x(8)

SPECIFICATIONS

Type	Flange connection DN in mm	Opening mm	Mixing valve k_{vs} -value m^3/h	Divertng valve k_{vs} -value m^3/h	Lifting height mm	Weight kg
80 M3F	80	80	80	69	11	35
100 M3F	100	100	125	108	13	44
125 M3F	125	125	215	185	18	72
150 M3F	150	150	310	267	20	111

3-way control valve type M3FA

Nodular cast iron, PN 10, DN 80 – 300 mm, except DN 200/175 and 200 mm - PN 16

0-2.3.10.01-B

Page 1 of 2

APPLICATIONS

Control valves type M3FA are designed for regulating of fresh water, lubricating oil and other liquid media. The valves are designed for use in conjunction with large industrial processes, district heating and marine installations, e.g. cooling of main and auxiliary engines. The valve is designed for use in conjunction with Clorius valve motor type AVM234 or AVF234.

DESIGN

The valve components (seats and cone) are made of alu bronze, the spindle of stainless steel. The valve body is made of cast iron and the valve flanges are drilled according to EN 1092-2. Tight between port 1(AB) og 3(B) is optional.

FUNCTION

The valve cone is firmly connected with the motor spindle. When the valve cone is in the one extreme position by draw on the spindle, connection A-AB is kept fully open and connection B-AB is fully closed. In the other extreme position connection A-AB is fully closed and connection B-AB is fully open. In the intermediate positions the opening degrees change proportionally.



TECHNICAL DATA

Materials:

- Valve body	80 – 300 M3FA	Nodular cast iron EN-GJS-400-15
- Trim		Alu bronze, CuAL10Fe5Ni5
- Valve spindle		Stainless steel (W.no. 1.4436)
- O-ring		AFLAS A75H
- Gasket		Reinz-AFM34
Nominal pressure PN 10		
- 80-150 mm		PN 10 max. 120°C
- 200/175-200 mm		PN 16 max. 120°C
- 300/250-300 mm		PN 10 max. 120°C
Seals		2 balanced single seats
Flow characteristic		Almost linear
Leakage rate		0.5%
Regulating capability		Kvs/Kvr > 25
Temperature range		Max. 120° C
Flanges		EN 1092-2 PN 10/16

Note !

Valve type 200/175 M3FA has outer measures and flanges drilled as valve type 200 M3FA. Valve type 300/250 M3FA has outer measures and flanges drilled as valve type 300 M3FA.

Counter flanges (suggested)

80 – 150 M3FA: DIN 2632 – PN 10
200/175 – 200 M3FA: DIN 2633 – PN 16
300/250 – 300 M3FA: DIN 2632 – PN 10

For cooling and heating purposes

Important note

In case the valves are applied as diverting valves, the pressure drop will increase by 35% and the k_{vs} -value will decrease by 14% as against mixing.

Subject to change without notice.

FEATURES

- Can be used for both mixing and diverting
- Simple design secures reliable controls and reduces costly downtime
- Location of the pack box in the actuator makes the valve service friendly

PRESSURE/TEMPERATURE DIAGRAM

According to DIN 2401

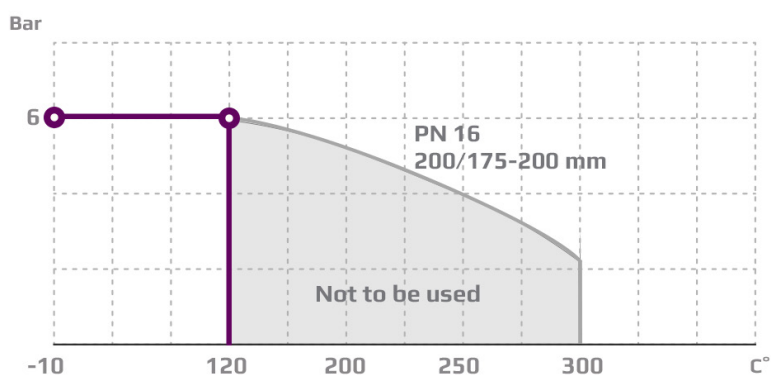
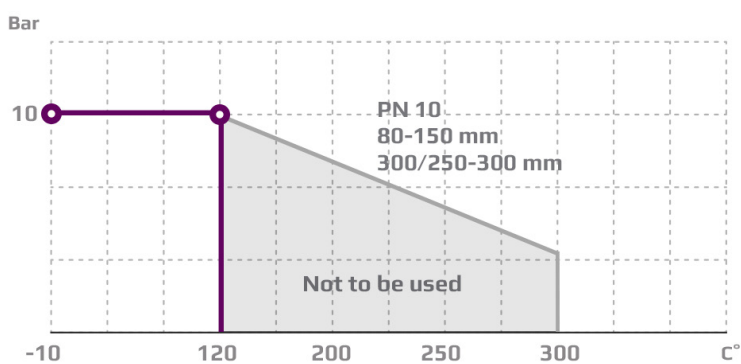

PORT NUMBERING

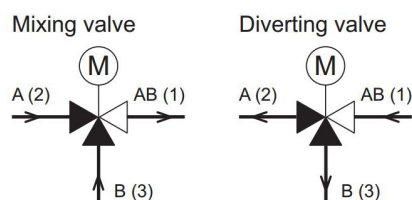

Port AB
Port A
Port B

common port always open
closes at load on spindle
opens at load on spindle

The valves can be installed with vertical as well as horizontal spindles. The valves must be mounted in a way that the valve motor will be exposed to a minimum of moisture and unnecessary vibrations. Free height above / below the valve must be minimum 400 mm for mounting and operation of the AFM 234 or AVF234 motor. See drawing.

DIMENSION SKETCH

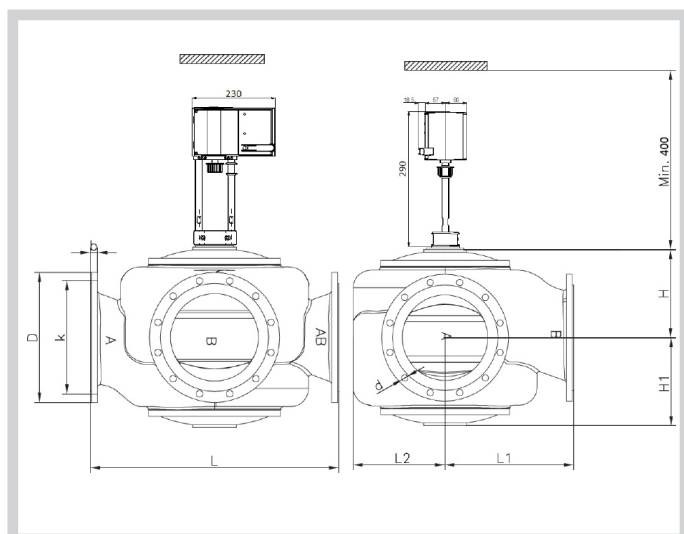

Type	L mm	L1 mm	H mm	H1 mm	b mm	D	k (dia.)	d mm dia.
80 M3FA	310	155	117	127	20	200	160	18x(8)
100 M3FA	350	175	132	141	22	220	180	18x(8)
125 M3FA	400	240	181	171	24	250	210	18x(8)
150 M3FA	480	270	216	189	24	285	240	23x(8)
200/175	600	325	238	238	20	340	295	23x(12)
200 M3FA	600	325	238	238	20	340	295	23x(12)
300/250	850	450	305	305	25	445	400	23x(12)
300 M3FA	850	340	305	305	25	445	400	23x(12)

SPECIFICATIONS

Type	Flange connection DN in mm	Opening mm	k_{vs} -value ¹⁾ mixing m ³ /h	k_{vs} -value ¹⁾ diverting m ³ /h	Lifting height mm	Weight kg
80 M3FA	80	80	80	69	11	35
100 M3FA	100	100	125	108	13	44
125 M3FA	125	125	215	185	18	72
150 M3FA	150	150	310	267	20	111
200/175 M3FA	200	200	425	366	22	165
200 M3FA	200	200	555	477	28	160
300/250 M3FA	300	300	865	744	28	306
300 M3FA	300	300	1250	1075	45	290

¹⁾ The stated k_{vs} values apply for mixing valves. Diverting valves: $0.86 \times (k_{vs}$ -values for mixing valves).



3-way Control Valve type M3F-I

Nodular cast iron, PN 10, DN 150 mm

0-2.3.12-B

Page 1 of 2



TECHNICAL DATA

Materials:	
- Valve body	Nodular cast iron EN-GJS-400-15
- Seats and cone	Alu bronze CuAL10Fe5Ni5
- Spindle	Stainless steel (W.no. 1.4436)
- O-ring	90 NBR
- Gasket	Reinz-AFM34
Nominal pressure	PN 10
Seating	Two balanced single seats
Flow characteristic	Almost linear
Flanges drilled according to	EN 1092-2 PN 10
Counter flanges	DIN 2632
Leakage rate	0,5 %
Regulating capability	Kvs/Kvr > 25

For regulating of process and central heating plants

Important note

In case the valves are applied as diverting valves, the pressure drop will increase by 35% and the k_{vs} -value will decrease by 14% as against mixing valves.

Subject to change without notice.

APPLICATIONS

Control valves type M3F-I are designed for regulating of water, lubricating oil and other liquid media and can be mounted in the pipe system as either mixing or diverting valves. However when mounting as a diverting valve the pressure drop is increased, compared with mounting as a mixing valve. See "Important note" under Technical Data. The valves are used in conjunction with our temperature regulators for controlling industrial processes, district and central heating plants and marine installations.

DESIGN

The valve components - seats and cone are made of alu bronze, the spindle is made of stainless steel. The valve body is made of nodular cast iron EN-GJS-400-15 with flanges drilled according to EN 1092-2. The connection thread for the actuator is G1B ISO 228. The valves have two balanced single seats. The leakage rate is less than 0.5% of the full flow (according to VDI/VDE 2174).

FUNCTION

Without an actuator being installed, connection B-AB is fully open and connection A-AB completely closed, by means of a spring. By increasing pressure on the spindle, the opening of the ports changes proportionally to the travel of the spindle, and when the spindle is pressed to the bottom, connection A-AB is fully open and connection B-AB completely closed.

FEATURES

- Can be used for both mixing and diverting
- Simple design secures reliable controls and reduces costly downtime
- Location of the pack box in the actuator makes the valve service friendly

PRESSURE/TEMPERATURE DIAGRAM

According to DIN 2401

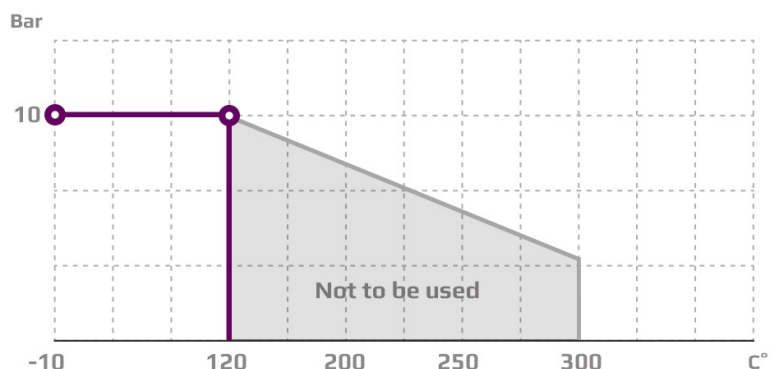

PORT NUMBERING

The ports of valves type M3F-I are marked with the letters AB, A and B.

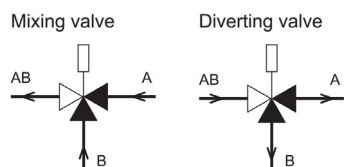

Port AB
Port A
Port B

common port always open
closes at load on spindle
opens at load on spindle



MOUNTING

The valves can be installed with vertical as well as horizontal spindles. The valves must be mounted in a way that the valve actuator will be exposed to a minimum of moisture and unnecessary vibrations.

DIMENSION SKETCH

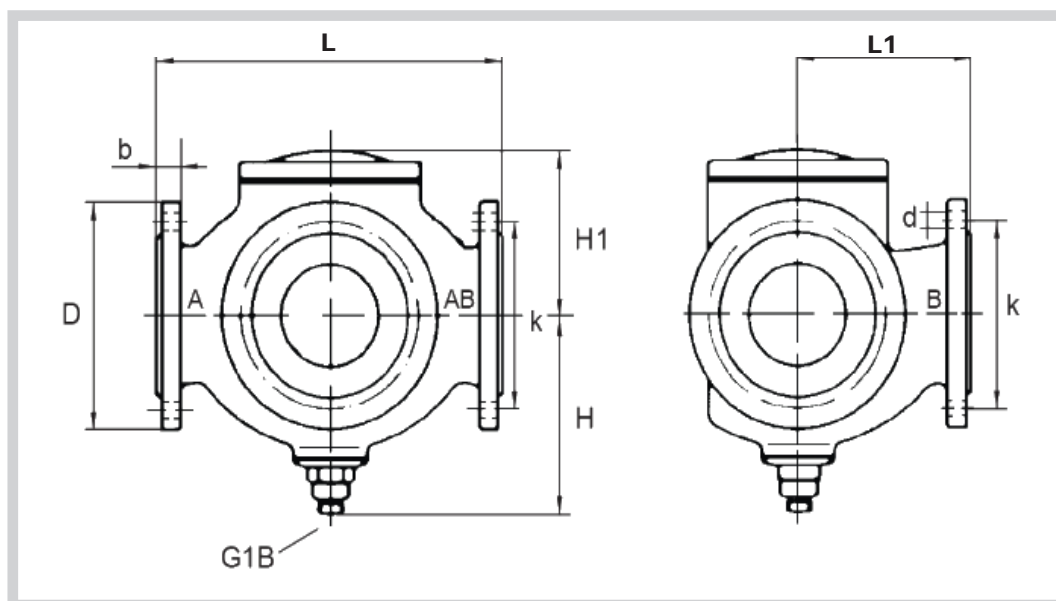

Type	L mm	L1 mm	H mm	H1 mm	D (dia.) mm	b mm	k (dia.) mm	d mm dia. (number)
150 M3F-I	480	270	280	189	285	24	240	22x(8)

SPECIFICATIONS

Type	Flange connection DN in mm	Opening mm	Mixing valve k_{vs} -value m^3/h	Divertng valve k_{vs} -value m^3/h	Lifting height mm	Weight kg
150 M3F-I	150	150	310	267	20	111

3-way Control Valve type M3FA-I (Ports A-AB interchanged)

Nodular cast Iron, PN 10, DN 80 – 300 mm, DN 200/175 and 200 mm/PN 16

0-2.3.12.02-D

Page 1 of 2



APPLICATIONS

Control valves type M3FA-I are designed for regulating of fresh water, lubricating oil and other liquid media. The valves are designed for use in conjunction with large industrial processes, district heating and marine installations, e.g. cooling of main and auxiliary engines. To be used with AVM234 or AVF234 electric actuators.

DESIGN

The valve components (seats and cone) are made of alu bronze, the spindle of stainless steel. The valve body is made of nodular cast iron and the valve flanges are drilled according to EN 1092-2.

FUNCTION

The valve cone is firmly connected with the motor spindle. When the valve cone is in the one extreme position by draw on the spindle, connection B-AB is kept fully open and connection A-AB is fully closed. In the other extreme position connection B-AB is fully closed and connection A-AB is fully open. In the intermediate positions the opening degrees change proportionally.

TECHNICAL DATA

Materials:	
- Valve body	Nodular cast iron EN-GJS-400-15
- Trim	Alu Bronze CuAL10Fe5Ni5
- Valve spindle	Stainless steel (W.no. 1.4436)

Nominal pressure
- DN200/175-200 M3FA-I
 PN 16/232 psi max -20°C/248°F

- DN300/250-300 M3FA-I
 PN 10/145 psi max.120°C/248°F

Seats	2 balanced single seats
Flow characteristic	Almost linear
Leakage rate	0.5%
Regulating capability	Kvs/Kvr > 25
Temperature range	Max. 120° C/248°F

Flanges
 EN 1092-2 PN 10/16
 EN 1092-2 145/232 psi

Note !
 Valve type 200/175 M3FA-I has outer measures and flanges drilled as valve type 200 M3FA-I Valve type 300/250 M3FA-I has outer measures and flanges drilled as valve type 300 M3FA-I

Counter flanges (suggested)
- DN 200/175-200 M3FA-I DIN 2633 – PN 16 -
- DN 300/250-300 M3FA-I DIN 2632 – PN 10

For cooling and heating purposes

Important note

In case the valves are applied as diverting valves, the pressure drop will increase by 35% and the kvs-value will decrease by 14% as against mixing valves.

FEATURES

Can be used for both mixing and diverting
 Simple design secures reliable controls and reduces costly downtime
 Location of the pack box in the actuator makes the valve service friendly

PRESSURE/TEMPERATURE DIAGRAM

According to DIN 2401

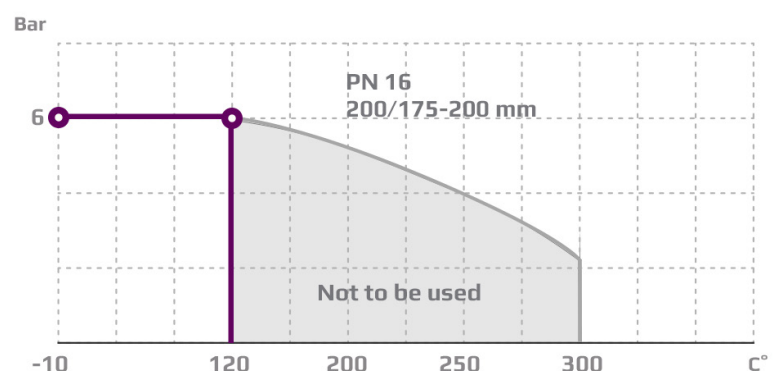
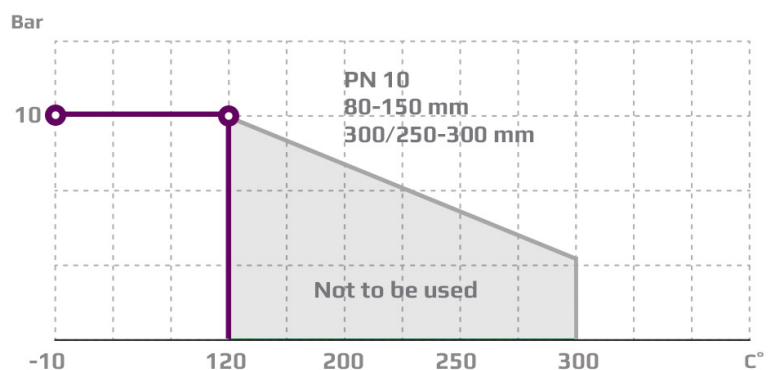

PORT NUMBERING

The ports of valves type M3FA-I are marked with the letters AB, B and A.

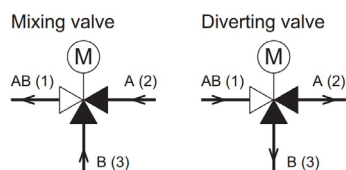

Port AB
Port A
Port B

common port always open
opens at load on spindle
closes at load on spindle



MOUNTING

The valves can be installed with vertical as well as horizontal spindles. The valves must be mounted in a way that the valve motor will be exposed to a minimum of moisture and unnecessary vibrations. Free height above / below the valve must be minimum 400 mm for mounting and operation of the AVM/AVF 234 motor. See drawing.

DIMENSION SKETCH

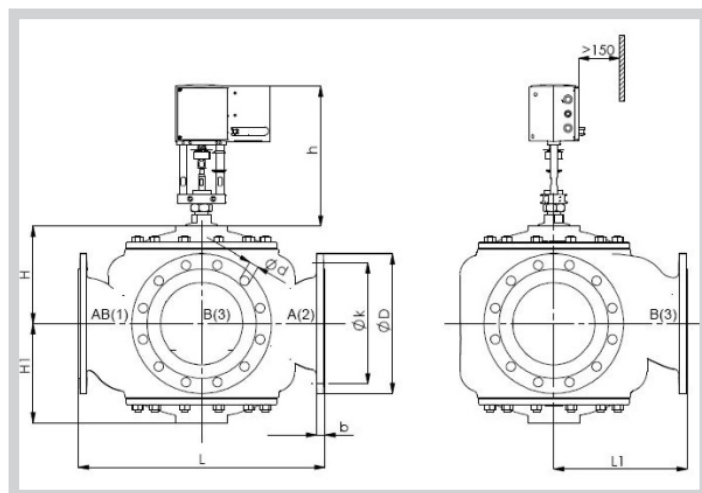

Type	L mm	L1 mm	H mm	H1 mm	b mm	D (dia.) mm	k (dia.) mm	d mm dia. (number)
80 M3FA-I	310	155	117	127	20	200	160	18x(8)
100 M3FA-I	350	175	132	141	22	220	180	18x(8)
125 M3FA-I	400	240	181	171	24	250	210	18x(8)
150 M3FA-I	480	270	216	189	24	285	240	23x(8)
200/175	600	325	238	238	20	340	295	23x(12)
200 M3FA-I	600	325	238	238	20	340	295	23x(12)
250 M3FA-I	850	340	305	305	25	445	400	23x(12)
300 M3FA-I	850	450	305	305	25	445	400	23x(12)

SPECIFICATIONS

Type	Flange connection DN in mm	Opening mm	k_{vs} -value ¹⁾ mixing m ³ /h	k_{vs} -value ¹⁾ diverting m ³ /h	Lifting height mm	Weight kg
80 M3FA-I	80	80	80	69	11	35
100 M3FA-I	100	100	125	108	13	44
125 M3FA-I	125	125	215	185	18	72
150 M3FA-I	150	150	310	267	20	111
200/175 M3FA-I	200	200	425	366	22	165
200 M3FA-I	200	200	555	477	28	160
300/250 M3FA-I	300	300	865	744	28	306
300 M3FA-I	300	300	1250	1075	45	290

¹⁾ The stated k_{vs} values apply for mixing valves. Diverting valves: $0.86 \times (k_{vs}$ -values for mixing valves).

2-way Control Valve type H1F

Cast steel, PN 40, DN 15/4 – 50 mm

0-2.4.02-K

Page 1 of 2

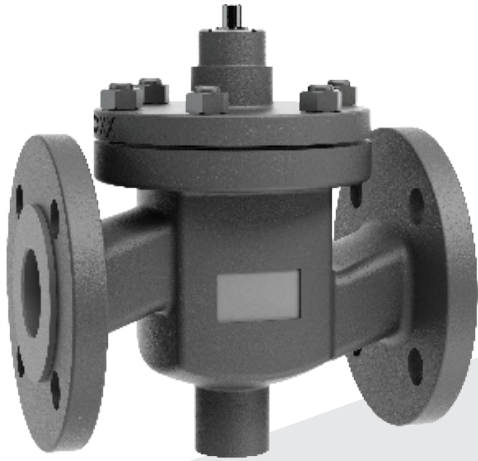

APPLICATIONS

Control valves type H1F are designed for regulating hot water, steam and hot oil systems. The valves are used in conjunction with our temperature or pressure differential regulators for controlling industrial processes, district or central heating plants or marine installations.

DESIGN

The valve components - spindle, seat and cone - are made of stainless steel. The valve body is made of cast steel GP240GH (GS-C25) with flanges drilled according to EN 1092-1 or ANSI B16.5 Class 150. The thread for the actuator connection is G1B ISO 228. The valves are single-seated. The leakage rate is less than 0.05% of the full flow (according to VDI/VDE 2174).

FUNCTION

Without the actuator being connected, the valve is held in open position by means of a spring. With pressure on the spindle the valve will close. In connection with our thermostats, electric or pneumatic actuators, the valves will close at rising temperatures. For cooling circuits the valve can be used in conjunction with a reverse acting electric actuator. Alternatively a reverse acting valve can be used with our self-acting thermostats. The quadratic characteristic will not cease until the flow has dropped below 4% of the full flow.

TECHNICAL DATA

Materials:	
- Valve body	Cast steel GP240GH (GS-C25)
- Trim	Stainless steel
- Bolts, nuts	24 CrMo 4/A4
- Gasket	Graphite and stainless steel foil
Nominal pressure	PN 40
Seating	Single seated, tight closing
Flow characteristic	Quadratic
Leakage rate	$\leq 0.05\%$ of Kvs
Regulating capability	Kvs/Kvr > 25
Flanges drilled according to	EN 1092-1 PN 40 or ANSI B16.5 Class 150
Counter flanges	DIN 2635

FEATURES

- Simple design secures reliable controls
- Location of the pack box in the actuator makes the valve service friendly
- Reliable and secure due to internal parts of stainless steel
- Low leakage rate reduces the risk of overheating

PRESSURE/TEMPERATURE DIAGRAM

According to DIN 2401

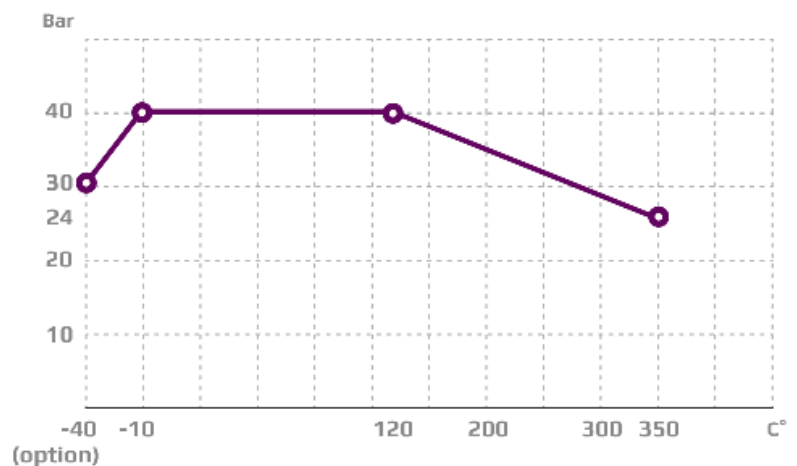

Subject to change without notice.

MOUNTING

The valve can be installed with vertical as well as horizontal spindles. For valve temperatures of max. 170 °C, the thermostat/ actuator can be fitted below or above the valve. For valve mounted with thermostats in media temperatures above 170 °C, a cooling unit has to be applied with connection downwards (please refer to data sheet for thermostat accessories). For electric actuators a high temperature adaptor must be used (please refer to data sheets for the electric actuators).



DIMENSION SKETCH

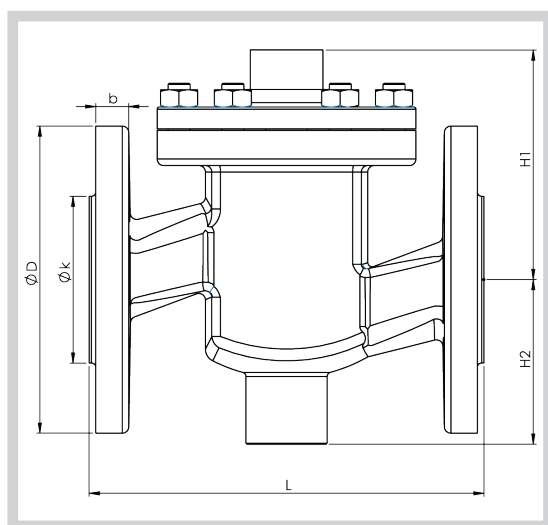

SPECIFICATIONS

Type	Flange connection DN in mm	Opening (mm)	k_{vs} -value m^3/h	Lifting height (mm)	Weight (kg)
15/4 H1F	15	4	0.20	6	3.3
15/6 H1F	15	6	0.45	6	3.3
15/9 H1F	15	9	0.95	6	3.4
15/12 H1F	15	12	1.7	6	3.4
15 H1F	15	15	2.75	6	3.4
20/4 H1F	20	4	0.2	6.5	4.7
20/6 H1F	20	6	0.45	6.5	4.7
20/9 H1F	20	9	0.95	6.5	4.7
20 H1F	20	20	5	6.5	4.9
25 H1F	25	25	7.5	7	6.1
32 H1F	32	32	12.5	8	9.0
40 H1F	40	40	20	9	10.8
50 H1F	50	50	30	10	15.5

Type	L (mm)	H1 (mm)	H2 (mm)	b (mm)	EN 1092-1			ANSI B16.5 Class 150		
					D (dia.) (mm)	k (dia.) (mm)	d mm dia.	D (dia.) (mm)	k (dia.) (mm)	d mm dia.
15/4 H1F	130	80	60	16	95	65	14x(4)	89	61	16x(4)
15/6 H1F	130	80	60	16	95	65	14x(4)	89	61	16x(4)
15/9 H1F	130	80	60	16	95	65	14x(4)	89	61	16x(4)
15/12 H1F	130	80	60	16	95	65	14x(4)	89	61	16x(4)
15 H1F	130	80	60	16	95	65	14x(4)	89	61	16x(4)
20/4 H1F	150	85	65	18	105	75	14x(4)	98	70	16x(4)
20/6 H1F	150	85	65	18	105	75	14x(4)	98	70	16x(4)
20/9 H1F	150	85	65	18	105	75	14x(4)	98	70	16x(4)
20 H1F	150	85	65	18	105	75	14x(4)	98	70	16x(4)
25 H1F	160	95	70	18	115	85	14x(4)	108	79	16x(4)
32 H1F	180	105	75	18	140	100	18x(4)	118	89	16x(4)
40 H1F	200	110	85	18	150	110	18x(4)	127	98	16x(4)

Balanced 2-way Control Valve type H1FB

Cast steel, PN 40, DN 25 – 80 mm

0-2.4.03-I

Page 1 of 2



TECHNICAL DATA

Materials:

- Valve body	Cast steel GP240GH (GS-C25)
- Components	Stainless steel
- Gasket	Copper and graphite Reinz-AFM34
- Bellows	Stainless steel W.1.4541
- Bolts, nuts	24 CrMo 4/A4
Nominal pressure	PN 40
Seating	Single seated, tight closing
Flow characteristic	Quadratic
Leakage rate	$\leq 0.05\%$ of Kvs
Regulating capability	Kvs/Kvr > 25
Flanges	EN 1092-1 PN 40
Pressure balanced	

Subject to change without notice.

APPLICATIONS

The pressure balanced control valves type H1FB are designed for regulating hot water, steam, hot oil etc. and can be used if a single-seated valve is required, but where the system pressure and valve size, out of regard for the pressure force of the actuator, necessitate a pressure balanced valve. The valves are installed combined with one of our temperature regulators in control systems in domestic premises, district heating systems, industrial processes or marine installations.

DESIGN

The valve components - spindle, seat, cone and bellows - are made of stainless steel. The bellows for balancing the pressure is fitted on the valve spindle and it reduces the power necessary for closing the valve, as the upstream pressure of the medium through the hollow valve spindle acts outside and the pressure after the valve acts inside the bellows system. The valve body is made of cast steel GP240GH (GS-C25) with connection flanges drilled according to EN 1092-1. The connection thread for the actuator is G1B ISO 228. The valves are single seated and tight closing. The leakage is less than 0.05% of full flow (see VDI/VDE 2174).

FUNCTION

Without an actuator being connected, the valve is held in open position by means of a spring and the bellows system. With pressure on the spindle the valve will close. In connection with our thermostats, the valves will close at rising temperatures. For cooling circuits the valve can be used in conjunction with a reverse acting electric actuator. Alternatively a reverse acting valve can be used with our self-acting thermostats. The quadratic characteristic will not cease until the flow has dropped below 4% of the full flow.

FEATURES

- Simple design secures reliable controls
- Location of the pack box in the actuator makes the valve service friendly
- Reliable and secure due to internal parts of stainless steel
- Low leakage rate reduces the risk of overheating

PRESSURE/TEMPERATURE DIAGRAM

According to DIN 2401

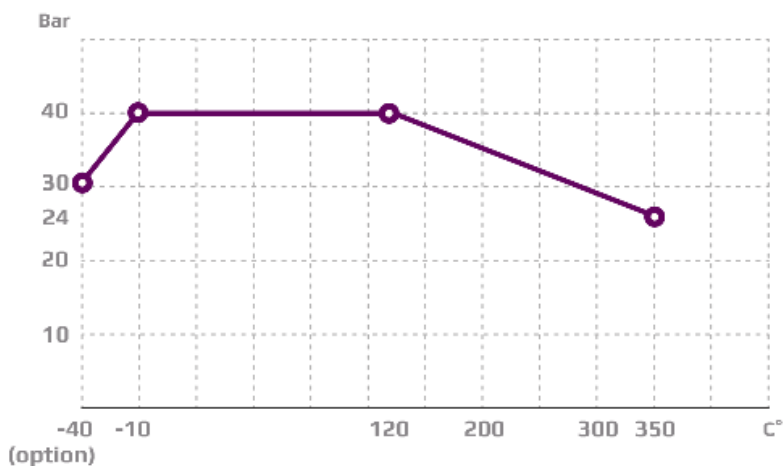



MOUNTING

The valve can be installed with vertical as well as horizontal spindles. For valve temperatures of max. 170 °C, the thermostat/ actuator can be fitted below or above the valve. For valve mounted with thermostats in media temperatures above 170 °C, a cooling unit has to be applied with connection downwards (please refer to data sheet for thermostat accessories). For electric actuators a high temperature adaptor must be used (please refer to data sheets for the electric actuators).

DIMENSION SKETCH

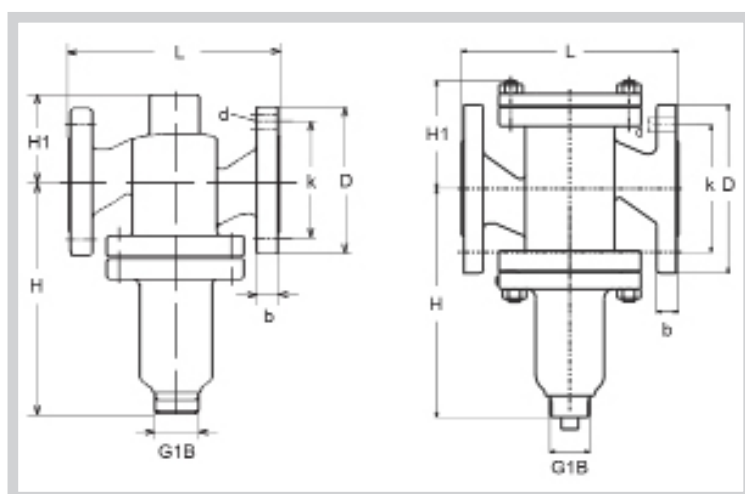

Type	L mm	H mm	H1 mm	b mm	D (dia.) mm	k (dia.) mm	d mm dia. (number)
25 H1FB	160	180	70	18	115	85	14x(4)
32 H1FB	180	195	75	18	140	100	18x(4)
40 H1FB	200	205	85	18	150	110	18x(4)
50 H1FB	230	225	95	20	165	125	18x(4)
65 H1FB	290	260	110	22	185	145	18x(8)
80 H1FB	310	275	115	24	200	160	18x(8)

SPECIFICATIONS

Type	Flange connection DN in mm	Opening (mm)	k_{vs} -value m^3/h	Lifting height (mm)	Weight (kg)
25 H1FB	25	25	7.5	7	6
32 H1FB	32	32	12.5	8	9
40 H1FB	40	40	20	9	13
50 H1FB	50	50	30	10	16
65 H1FB	65	65	50	13	23
80 H1FB	80	80	80	16	38

Balanced 2-way Control Valve type H1FBN

Cast steel, PN 40, DN 15 – 80 mm

0-2.4.03.01-G

Page 1 of 2



TECHNICAL DATA

Materials:

- Valve body	Cast steel GP240GH (GS-C25)
- Components	Stainless steel
- Nuts, bolts	24 CrMo 5/A4
- Gasket	Stainless steel foil
- O-ring	A75H FEPM

Nominal pressure	PN 40
Seating	Single seated, balanced

Flow characteristic	Quadratic
Leakage rate	$\leq 0.05\%$ of Kvs
Regulating capability	Kvs/Kvr > 25

Flanges drilled according to Pressure balanced valve	EN 1092-1 PN 40
------------------------------------------------------------	-----------------

APPLICATIONS

Balanced control valves type H1FBN are designed for regulating hot water, steam and hot oil systems. Balanced valves are used in installations where the system pressure necessitates a closing force greater than available in the actuator programme for a standard single seated valve, and where the leakage rate for a double-seated valve is unacceptable. The valves are used in conjunction with our temperature- or pressure differential regulators for controlling industrial processes, district or central heating plants or marine installations.

DESIGN

The valve components - spindle, seat, cone - are made of stainless steel. The valve body is made of cast steel GP240GH (GS-C25). The thread for the actuator connection is G1B ISO 228. The valves are single-seated. The leakage rate is less than 0.05% of the full flow (according to VDI/VDE 2174).

FUNCTION

Without an actuator being connected, the valve is held in open position by means of a spring. With force on the spindle the valve will close. In connection with our thermostats, pneumatic or electric actuators, the valves will close at rising temperatures. For cooling circuits the valve can be used in conjunction with a reverse acting electric actuator. Alternatively a reverse acting double seated valve can be used with our self-acting thermostats. The quadratic characteristic will not cease until the flow has dropped below 4% of the full flow.

FEATURES

- Simple design secures reliable controls
- Location of the pack box in the actuator makes the valve service friendly
- Reliable and secure due to internal parts of stainless steel
- Low leakage rate reduces the risk of overheating

PRESSURE/TEMPERATURE DIAGRAM

According to DIN 2401

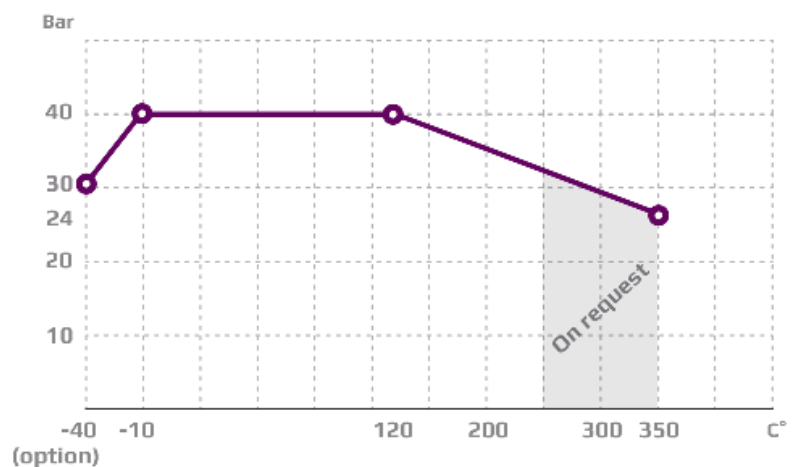

Subject to change without notice.

MOUNTING

The valve can be installed with vertical as well as horizontal spindles. For valve temperatures of max. 170 °C, the thermostat/ actuator can be fitted below or above the valve. For valve mounted with thermostats in media temperatures above 170 °C, a cooling unit has to be applied with connection downwards (please refer to data sheet for thermostat accessories). For electric actuators a high temperature adaptor must be used (please refer to data sheets for the electric actuators).



DIMENSION SKETCH

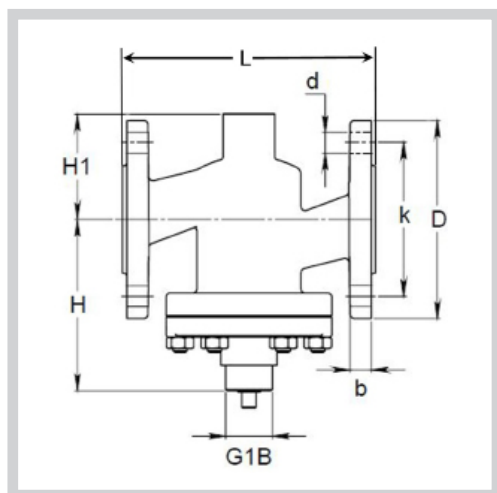

Type	L mm	H mm	H1 mm	b mm	D (dia.) mm	k (dia.) mm	d mm dia. (number)
15 H1FB	130	101	80	14	95	65	14x(4)
20 H1FB	150	107	85	16	105	75	14x(4)
25 H1FB	160	112	70	16	115	85	14x(4)
32 H1FB	180	122	75	18	140	100	18x(4)
40 H1FB	200	125	85	19	150	110	18x(4)
50 H1FB	230	140	95	19	165	125	18x(4)
65 H1FB	290	154	110	19	185	145	18x(8)
80 H1FB	310	164	115	19	200	160	19x(8)

SPECIFICATIONS

Type	Flange connection DN in mm	Opening (mm)	k_{vs} -value m^3/h	Lifting height (mm)	Weight (kg)
15 H1FBN	15	15	4	7.5	4
20 H1FBN	20	20	6.3	7.5	5
25 H1FBN	25	25	10	9	6
32 H1FBN	32	32	16	10	9
40 H1FBN	40	40	25	11	13
50 H1FBN	50	50	35	11.5	16
65 H1FBN	65	65	58	14.5	23
80 H1FBN	80	80	80	16	38

2-Way Control Valve Type H1FBE and H1FBE HV

with SC Pneumatic Actuator and PPL or PS-2 Positioners

Cast Steel, Single Seat Balanced, PN 25, DN 200-300, Flanged Ends

O-2.4.04-A

Page 1 of 4



APPLICATIONS

Control valves type H1FBE and H1FBE HV are designed for regulating steam hot water systems and liquid medias other than water.

The valves are used in conjunction with our temperature or pressure regulators for controlling industrial processes, municipal or domestic heating systems and marine installations.

Control valves type H1FBE HV are equipped with an additional cooling unit located between the valve and pneumatic actuator. This allows the system to be used in high ambient temperature environments. It also protects additional equipment such as positioners, filter regulators etc. from over-heating and prevents damage caused as a result.

DESIGN

The valve components - spindle, seat and cone - are made of stainless steel. The valve body is made of cast steel GP240GH with flanges drilled according to EN 1092-1. The leakage rate is 0.01%.

FUNCTION

Pressure on the spindle causes the valve to close.

The steam valve is based on a "balancing plug" design.

This means that a low and constant actuating force is necessary to operate the valve over all pressure ranges (0 – 25 Bar/0-363 psi)

TECHNICAL DATA

Valve size	DN 200/8" DN 250/10" DN 300/12"
Valve design	Linear
Max working temperature	225°C/437°F
Materials	
Valve body/cover	Cast Steel P240GH
Cone/seat/shaft	Stainless steel
Gasket	TFM and PVMQ
	Graphite metal
Bolts/nuts	Stainless steel A2-70
Color	
Valve	RAL7016
Protection shield	RAL6018
Flange drilled according to:	EN 1092-1 PN 25/363 psi ANSI 150
Counter flanges	JIS 5K, JIS 10K DIN2635
Kvs-value (M³/h)	DN 200/8" 725 M ³ /h DN 250/10" 1,000 M ³ /h DN 300/12" 1,500 M ³ /h
Flow characteristic	Up to 0.01% of Kvs Equal percentage + linear
Regulating capability	kvs/kvr > 50

Accessories

PNEUMATIC POSITIONER PPL (See data sheet O-6.6.01)

PNEUMATIC POSITIONER EPL (See data sheet O-6.6.02)

SMART POSITIONER PS-2 (See data sheet O-6.9.01)

FILTER REGULATOR AW20K (See data sheet O-6.8.01)

Subject to change without notice.

FEATURES

- 2-way steam valve with linear pneumatic actuator type SC
- Manual override operation
- Linear - equal percentage flow characteristic
- For high flow applications
- For control devices such as PPL, EPL and PS-2

FUNCTION continued

Pneumatic actuator SC (Spring Close) means that springs close the valve cone in case of air failure.

The pneumatic actuator contains a manual override function.

The manual override should be operated as follows:

AIR PRESSURE MUST BE DISCONNECTED WHEN USING THE MANUAL OVERRIDE. BEFORE CHANGING FROM MANUAL CONTROL TO AUTOMATIC MODE, THE MANUAL OVERRIDE MUST BE SET TO MINIMUM (CLOSE) POSITION.

OPTIONS

- The protection shield of the pneumatic actuators can be supplied without air ventilation holes. This allows the system to be used in rugged environments.
- Pneumatic 3/2 WAY VALVE – AUTO/MANUAL SWITCH

PRESSURE/TEMPERATURE DIAGRAM

According to DIN 2401

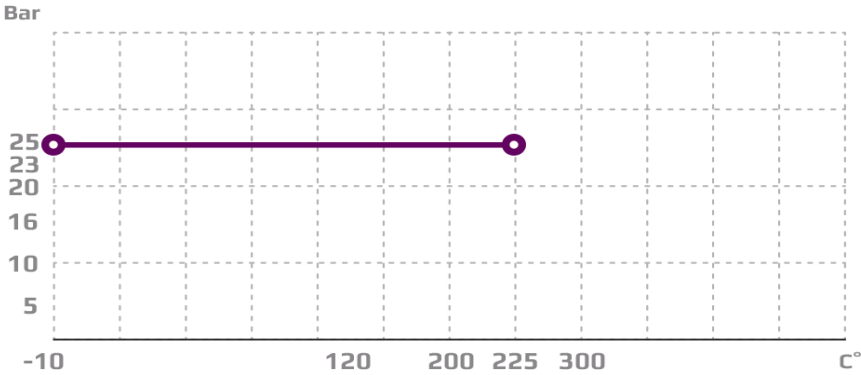

MOUNTING

The valve can be installed both vertically and horizontally.

CHARACTERISTICS

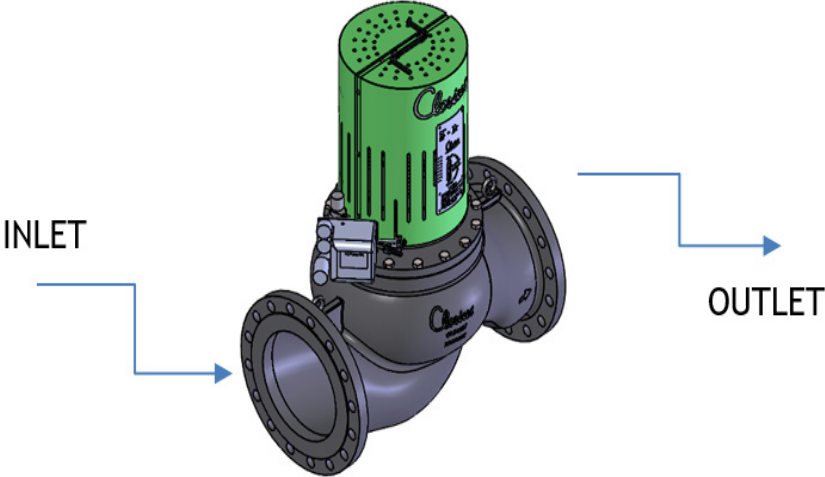
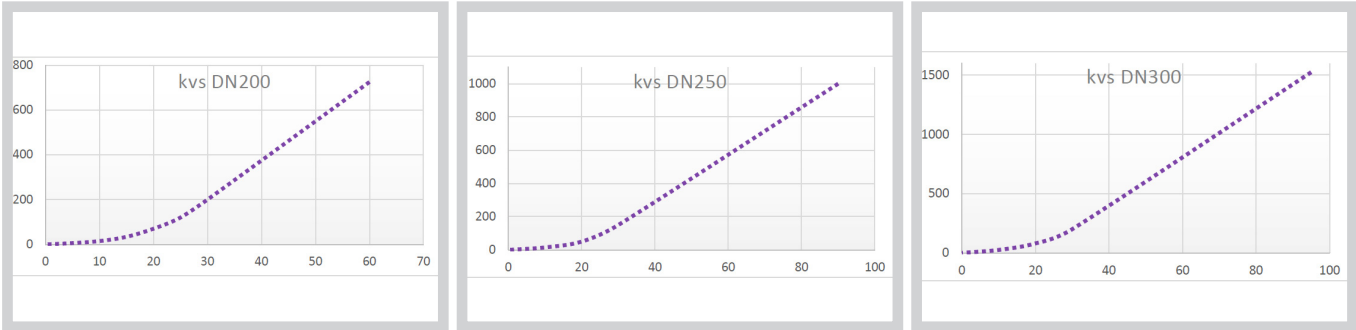

2-Way Control Valve Type H1FBE and H1FBE HV

with SC Pneumatic Actuator and PPL or PS-2 Positioners

Cast Steel, Single Seat Balanced, PN 25, DN 200-250, Flanged Ends

O-2.4.04-A

Page 3 of 4

DIMENSION SKETCH

DIMENSIONS IN MM

Control valve H1FBE with pneumatic actuator and positioner

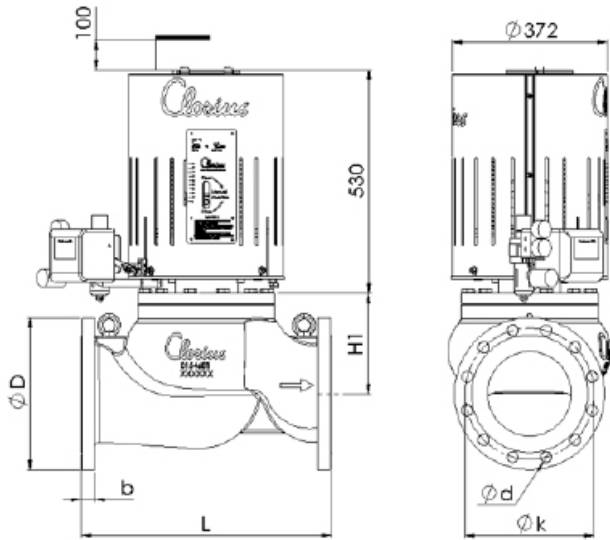

DIMENSIONS IN MM

Control valve H1FBE HV with pneumatic actuator, positioner and cooling unit

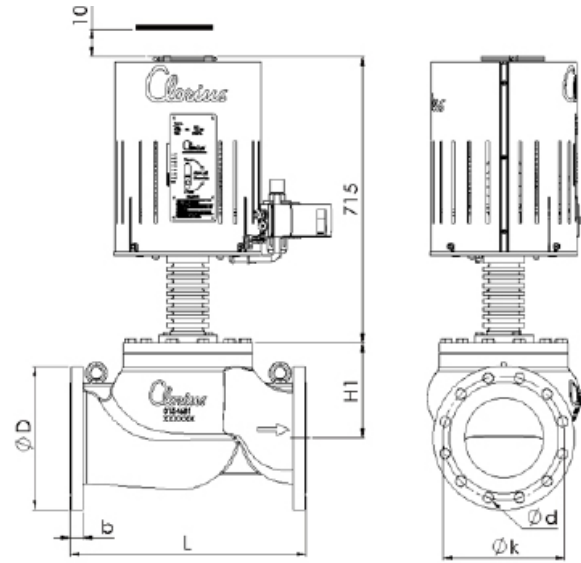

Size	Norm	L (mm)	L (inch)	H1 (mm)	H1 (inch)	D (dia.) (mm)	D (dia.) (inch)	b (mm)	b (inch)	k 1,3" (dia.) (mm)	k 1,3" (dia.) (inch)	d (mm/inch) dia.
DN 200	EN1092-1	600	24	238	9.3	360	14	30	1	310	12	12 x Ø26/1
	ANSI150	600	24	238	9.3	343	13.5	30	1	298	12	8 x Ø22/0.8
	JIS 5K	600	24	238	9.3	320	12.5	30	1	280	11	8 x Ø23/0.9
	JIS 10K	600	24	238	9.3	320	12.5	30	1	290	11	12 x Ø23/0.9
DN 250	EN1092-1	730	29	227	8.9	425	17	32	1.3	370	14.5	12 x Ø30/1
	ANSI150	730	29	227	8.9	406	16	32	1.3	362	14	12 x Ø25/0.9
	JIS 5K	730	29	227	8.9	385	15	32	1.3	345	13.5	12 x Ø23/0.9
	JIS 10K	730	29	227	8.9	400	16	32	1.3	355	14	12 x Ø25/0.9
DN 300	EN1092-1	850	33	301	11.8	485	19	32	1.3	430	17	16 x Ø30/1
	ANSI150	850	33	301	11.8	483	19	32	1.3	432	17	12 x Ø25/0.9
	JIS 5K	850	33	301	11.8	430	17	32	1.3	390	15	12 x Ø23/0.9
	JIS 10K	850	33	301	11.8	445	17.5	32	1.3	400	16	16 x Ø25/0.9

SPECIFICATION

Type	Opening mm/inch	k _{vs} rating m ³ /h	Lifting height mm/inch	Weight kg/lbs
DN 200 H1FBE	200/8	725	75/3	220/485 lbs
DN 200 H1FBE HV	200/8	725	75/3	225/496 lbs
DN 250 H1FBE	250/10	1,000	90/3.5	258/568 lbs
DN 250 H1FBE HV	250/10	1,000	90/3.5	263/579 lbs
DN 300 H1FBE	300/12	1,500	95/3.7	320/705 lbs
DN 300 H1FBE HV	300/12	1,500	95/3.7	320/705 lbs

ITEM NUMBERS

for standard Clorius Controls kits

Item no.	Description	Material	Pressure
1-7511750	VALVE DN 200 H1FBE PN 25 with SC pneumatic actuator and positioner	GP240GH	PN 25/363 psi
1-7511752	VALVE DN 200 H1FBE PN 25 with SC pneumatic actuator and positioner	GP240GH	PN 25/363 psi
1-7511754	VALVE DN 200 H1FBE HV PN 25 with SC pneumatic actuator and posi-	GP240GH	PN 25/363 psi
1-7511756	VALVE DN 200 H1FBE HV PN 25 with SC pneumatic actuator and position-	GP240GH	PN 25/363 psi
1-7511760	VALVE DN 250 H1FBE PN 25 with SC pneumatic actuator and positioner	GP240GH	PN 25/363 psi
1-7511762	VALVE DN 250 H1FBE PN 25 with SC pneumatic actuator and positioner	GP240GH	PN 25/363 psi
1-7511764	VALVE DN 250 H1FBE HV PN 25 with SC pneumatic actuator and posi-	GP240GH	PN 25/363 psi
1-7511766	VALVE DN 250 H1FBE HV PN 25 with SC pneumatic actuator and position-	GP240GH	PN 25/363 psi
1-7511770	VALVE DN 300 H1FBE PN 25 with SC pneumatic actuator and positioner	GP240GH	PN 25/363 psi
1-7511772	VALVE DN 300 H1FBE PN 25 with SC pneumatic actuator and positioner	GP240GH	PN 25/363 psi
1-7511774	VALVE DN 300 H1FBE HV PN 25 with SC pneumatic actuator and posi-	GP240GH	PN 25/363 psi
1-7511776	VALVE DN 300 H1FBE HV PN 25 with SC pneumatic actuator and position-	GP240GH	PN 25/363 psi

2-way Control Valve type H2F

Cast Steel, PN 40, DN 20 – 80 mm

0-2.4.05-L

Page 1 of 2



TECHNICAL DATA

Materials:

- Valve body	Cast steel GP240GH (GS-C25)
- Spring	1.4568
- Cone	1.4408, 1.4305
- Gasket	Stainless steel foil and graphite
- Upper seat	AISI 303
- Lower seat	1.4301, 1.4305, 1.4307
- Bolts, nuts	24 CrMo 4/A4
Nominal pressure	PN 40
Seating	Double-seated
Flow characteristic	Quadratic
Function	Closes by pressing the spindle
Leakage rate	$\leq 0.5\%$ of Kvs
Regulating capability	Kvs/Kvr > 25

Flanges drilled according to	EN 1092-1 PN 40
Counter flanges	DIN 2635
Adjustable seat interspace	

Subject to change without notice.

APPLICATIONS

Control valves type H2F are designed for regulating hot water, steam and hot oil systems. The double-seated valves are used in installations where the system pressure necessitates a closing force greater than available in the actuator programme for a single-seated valve. The valves are used in conjunction with our temperature or pressure differential regulators for controlling industrial processes, district or central heating plants or marine installations.

DESIGN

The valve components - spindle, seats and cone - are made of stainless steel. The valve body is made of cast steel GP240GH (GS-C25) with flanges drilled according to EN 1092-1. The connection thread for the actuator is G1B ISO 228. The valves are double-seated. The leakage rate is less than 0.5% of the full flow (according to VDI/VDE 2174).

FUNCTION

Without the actuator being connected, the valve is held in open position by means of a spring. With pressure on the spindle the valve will close. In connection with thermostats, pneumatic or electric actuators, the valves will close at rising temperatures. For cooling circuits the valve can be used in conjunction with a reverse acting electric actuator. Alternatively a reverse acting valve can be used with our self-acting thermostats. The quadratic characteristic will not cease, until the flow has dropped below 4% of the full flow.

FEATURES

- Simple design secures reliable controls
- Location of the pack box in the actuator makes the valve service friendly
- Reliable and secure due to internal parts of stainless steel

PRESSURE/TEMPERATURE DIAGRAM

According to DIN 2401

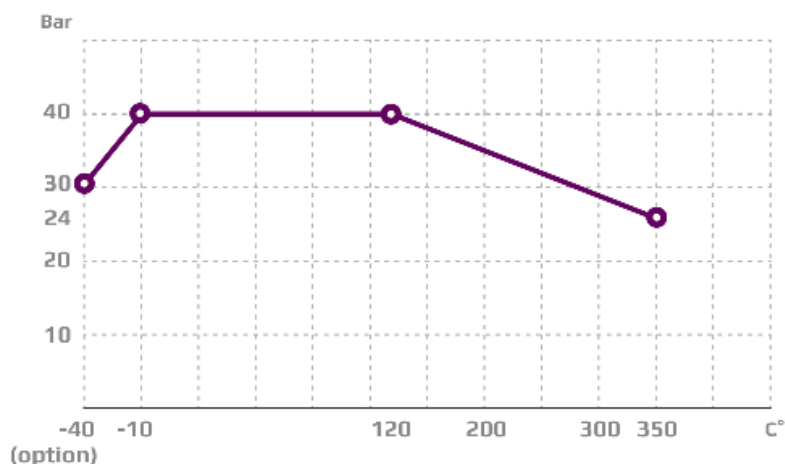



MOUNTING

The valve can be installed with vertical as well as horizontal spindles. For valve temperatures of max. 170 °C, the thermostat/ actuator can be fitted below or above the valve. For valve mounted with thermostats in media temperatures above 170 °C, a cooling unit has to be applied with connection downwards (please refer to data sheet for thermostat accessories). For electric actuators a high temperature adaptor must be used (please refer to data sheets for the electric actuators).

DIMENSION SKETCH

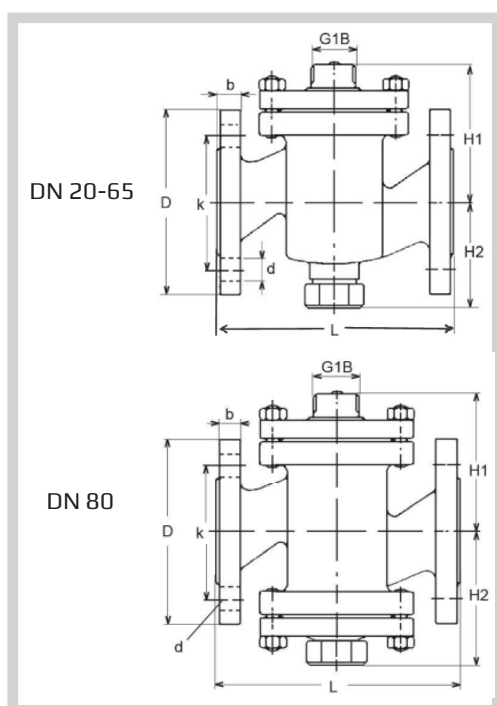

Type	L mm	H1 mm	H2 mm	b mm	D (dia.) mm	k (dia.) mm	d mm dia. (number)
20 H2F	150	85	70	18	105	75	14x(4)
25 H2F	160	95	77	18	115	85	14x(4)
32 H2F	180	105	82	18	140	100	18x(4)
40 H2F	200	110	92	18	150	110	18x(4)
50 H2F	230	125	102	20	165	125	18x(4)
65 H2F	290	135	120	22	185	145	18x(8)
80 H2F	310	145	165	24	200	160	18x(8)

SPECIFICATIONS

Type	Flange connection DN in mm	Opening (mm)	k_{vs} -value m ³ /h	Lifting height (mm)	Weight (kg)
20 H2F	20	20	5	6.5	5
25 H2F	25	25	7.5	7	6.5
32 H2F	32	32	12.5	8	9
40 H2F	40	40	20	9	11
50 H2F	50	50	30	10	16
65 H2F	65	65	50	11	21
80 H2F	80	80	80	13	38

2-way Control Valve type H2F

Cast Steel, PN 25, DN 100 – 150 mm / PN 16, DN 150 - 200 mm

0-2.4.06-M

Page 1 of 2



TECHNICAL DATA

Materials:	
- Valve body	Cast steel GP240GH (GS-C25)
- Components	Stainless steel
- Bolts, nuts	24 CrMo 4/A4
- Gaskets	Stainless steel foil and copper
Nominal pressure	PN 25
Seating	Double seated
Flow characteristic	Almost quadratic
Function	Closing with pressure on spindle
Leakage rate	$\leq 0.5\%$ of Kvs
Regulating capability	Kvs/Kvr > 25

Flanges drilled according to	EN1092-1 PN 25 - PN16 - DN 200
Counter flanges	N 2635

Note

All Clorius valves are approved in accordance to the Pressure Equipment Directive (PED). Valve type 150 H2F is only approved for nominal pressure PN 16, but for applications not effected by the PED, valve type 150 H2F can be delivered for nominal pressure PN 25

Subject to change without notice.

APPLICATIONS

Control valves type H2F are designed for use in regulating high pressure hot water, steam and heat transfer oil. The valves are used in conjunction with temperature or pressure differential regulators for controlling district or central heating plants, industrial processes or marine installations.

DESIGN

The valve components – spindle, seats and cone – are made of stainless steel. The valve body is made of cast steel GP240GH (GS-C25) with flanges drilled according to EN 1092-1. The connection thread for the actuator is G1B ISO 228. The valves are double-seated. The leakage rate is less than 0.5% of the full flow (according to VDI/VDE 2174).

FUNCTION

Without the actuator being connected, the valve is held in open position by means of a spring. With pressure on the spindle the valve will close. In connection with our thermostats, pneumatic or electric actuators, the valves will close at rising temperatures. For cooling circuits the valve can be used in conjunction with a reverse acting electric actuator. Alternatively a reverse acting valve can be used with our self-acting thermostats. The linear characteristic will not cease, until the flow has dropped below 4% of the full flow.

FEATURES

- Simple design secures reliable controls
- Location of the pack box in the actuator makes the valve service friendly
- Reliable and secure due to internal parts of stainless steel

PRESSURE/TEMPERATURE DIAGRAM

According to DIN 2401

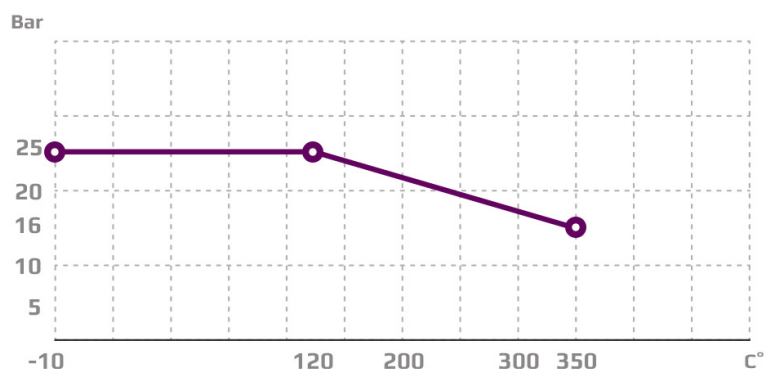



MOUNTING

The valve can be installed with vertical as well as horizontal spindles. For valve temperatures of max. 170 °C, the thermostat/ actuator can be fitted below or above the valve. For valve mounted with thermostats in media temperatures above 170 °C, a cooling unit has to be applied with connection downwards (please refer to data sheet for thermostat accessories). For electric actuators a high temperature adaptor must be used (please refer to data sheets for the electric actuators).

DIMENSION SKETCH

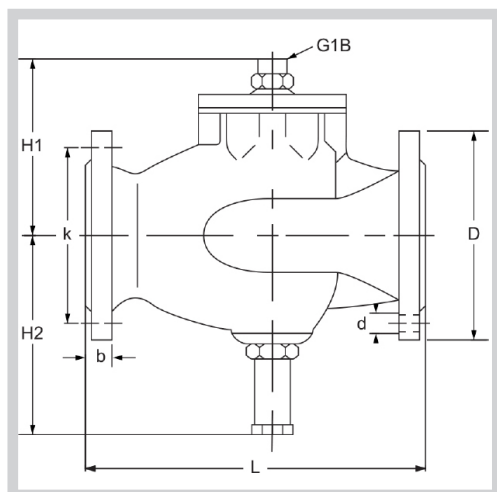

Type	L mm	H1 mm	H2 mm	D (dia.) mm	b mm	k (dia.) mm	d mm dia. (number)
100 H2F	350	185	209	235	24	190	23x(8)
125 H2F	400	240	230	270	26	220	27x(8)
150 H2F	400	240	230	300	28	250	27x(8)
*200 H2F	600	276	273	340	26	295	23x(12)

*EN1092-1 - PN16

SPECIFICATIONS

Type	Flange connection DN in mm	Opening (mm)	k_{vs} -value m^3/h	Lifting height (mm)	Weight (kg)
100 H2F	100	100	125	20	38
125 H2F	125	125	215	20	73
150 H2F	150	150	310	20	76
200 H2F	200	200	500	22	120

3-way Control Valve type H3F

Cast steel, PN 40, DN 20 – 65 mm, Flanged ends

0-2.4.07-L

Page 1 of 2

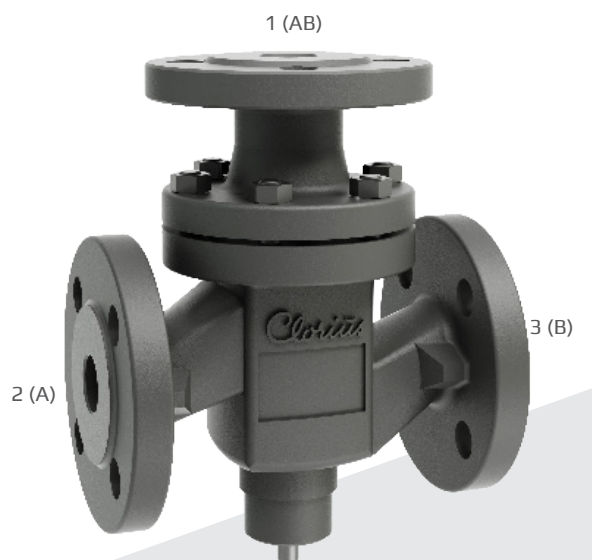

TECHNICAL DATA

Materials:

- Valve body	Cast steel GP240GH (GS-C25) (W. No. 1.0619)
- Trim	Stainless steel (W. No. 1.4305)
- Bolts, nuts	Steel (24 CrMo 4/A4)
- Gasket	Stainless steel foil and graphite
- O-Ring	70 EPM
Nominal pressure	PN 40
Seating	2 balanced single seats
Flow characteristic	Quadratic/linear
Leakage rate	$\leq 0.5\%$ of Kvs
Regulating capability	Kvs/Kvr > 25

Flanges drilled according to	EN 1092-1 PN 40
Counter flanges	DIN 2635
Same Kvs-value as mixing and diverting valve	

Subject to change without notice.

APPLICATIONS

Control valves type H3F are designed for control of hot oil, water and other liquids and can be installed in pipe systems as mixing or diverting valves. The valves are used in conjunction with our temperature regulators for controlling industrial processes, district or central heating plants or marine installations.

DESIGN

The valve components - spindle, seats and cone - are made of stainless steel. The valve body is made of cast steel GP240GH (GS-C25) with flanges drilled according to EN 1092-1. The thread for the actuator connection is G1B ISO 228. The valves have two balanced single seats. The leakage rate is less than 0.5% of the full flow (according to VDI/VDE 2174).

FUNCTION

Without an actuator being installed, connection A-AB is fully open and connection B-AB completely closed, by means of a spring.

By increasing pressure on the spindle, the opening of the ports changes proportionally to the travel of the spindle, and when the spindle is pressed to the bottom, connection B-AB is fully open and connection A-AB completely closed.

The valve characteristics are as follows:

Port A-AB and AB-A: quadratic

Port B-AB and AB-B: almost linear

These characteristics ensure constant total flow under almost all pressure conditions and optimum circulation in the individual circuits.

FEATURES

- Can be used for both mixing and diverting
- Simple design secures reliable controls and reduces costly downtime
- Location of the pack box in the actuator makes the valve service friendly

PRESSURE/TEMPERATURE DIAGRAM

According to DIN 2401

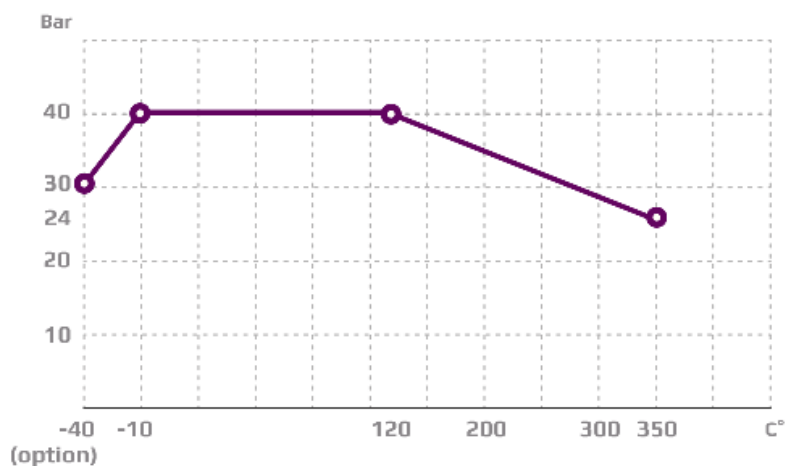

PORT NUMBERING

Valves type H3F are marked with the internationally recognized port designations: A, B, AB.

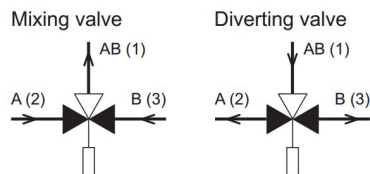

Port AB
Port A
Port B

common port always open
closes by activating the spindle
opens by activating the spindle

MOUNTING

The valve can be installed with vertical as well as horizontal spindles. For valve temperatures of max. 170 °C, the thermostat/ actuator can be fitted below or above the valve. For valve mounted with thermostats in media temperatures above 170 °C, a cooling unit has to be applied with connection downwards (please refer to data sheet for thermostat accessories). For electric actuators a high temperature adaptor must be used (please refer to data sheets for the electric actuators).

DIMENSION SKETCH

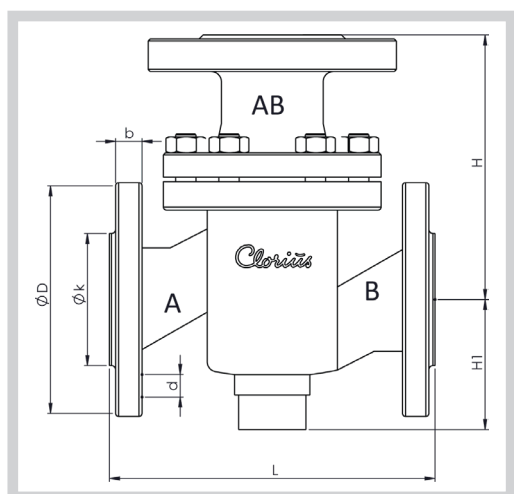

Type	L mm	H mm	H1 mm	D (dia.) mm	b mm	k (dia.) mm	d mm dia. (number)
20 H3F	150	115	63	105	16	75	14x(4)
25 H3F	160	130	70	115	18	85	14x(4)
32 H3F	180	150	75	140	18	100	18x(4)
40 H3F	200	160	85	150	18	110	18x(4)
50 H3F	230	190	95	165	20	125	18x(4)
60 H3F	290	220	110	185	20	145	18x(8)

SPECIFICATIONS

Type	Flange connection DN in mm	Opening (mm)	k_{vs} -value* m^3/h	Lifting height (mm)	Weight (kg)
20 H3F	20	20	6.3	7.5	6
25 H3F	25	25	10	9	7
32 H3F	32	32	16	10	10
40 H3F	40	40	25	11	14
50 H3F	50	50	38	11.5	18
65 H3F	65	65	63	14.5	26

* Same k_{vs} -values for mixing and diverting valves



3-way Control Valve type H3F

Cast steel, PN 16, DN 80 – 150 mm

0-2.4.08-B

Page 1 of 2



TECHNICAL DATA

Materials:	
- Valve body	Cast steel GP240GH (GS-C25)
- Seats and cone	Alu Bronze CuAL10Fe5Ni5
- Spindle	Stainless steel (W.no. 1.4436)
- Gasket	Reinz-AFM34
- O-ring	90 NBR
Nominal pressure	PN 16
Seating	2 balanced single seats
Flow characteristic	Almost linear
Temperature range	Max. 120 °C (160°C option)
Leakage rate	≤ 0.5% of Kvs
Regulating capability	Kvs/Kvr > 25
Flanges drilled according to	EN 1092-2 PN 16 or ANSI B16.5 Class 150
Counter flanges	DIN 2633

For regulating of process- and central heating plants

Important note

In case the valves are applied as diverting valves, the pressure drop will increase by 35% and the kvs-value will decrease by 14% as against mixing valves.

Subject to change without notice.

APPLICATIONS

Control valves type H3F are designed for regulating of hot water, lubricating oil and other liquid media and can be mounted in the pipe system as either mixing or diverting valves. However when mounting as a diverting valve the pressure drop is increased, compared with mounting as a mixing valve. See "Important note" under technical data. The valves are used in conjunction with our temperature regulators for controlling industrial processes, district and central heating plants and marine installations.

DESIGN

The valve components - seats and cone - are made of alu bronze, the spindle is made of stainless steel. The valve body is made of cast steel GP240GH (GS-C25) with flanges drilled according to EN 1092-2 or ANSI B16.5 Class 150. The connection thread for the actuator is G1B ISO 228. The valves have two balanced single seats. The leakage rate is less than 0.5% of the full flow (according to VDI/VDE 2174). Tight between port 1(AB) og 3(B) is optional.

FUNCTION

Without an actuator being installed, connection 2-1 is fully open and connection 3-1 completely closed, by means of a spring. By increasing pressure on the spindle, the opening of the ports changes proportionally to the travel of the spindle, and when the spindle is pressed to the bottom, connection 3-1 is fully open and connection 2-1 completely closed.

FEATURES

- Can be used for both mixing and diverting
- Simple design secures reliable controls and reduces costly downtime
- Location of the pack box in the actuator makes the valve service friendly

PRESSURE/TEMPERATURE DIAGRAM

According to DIN 2401

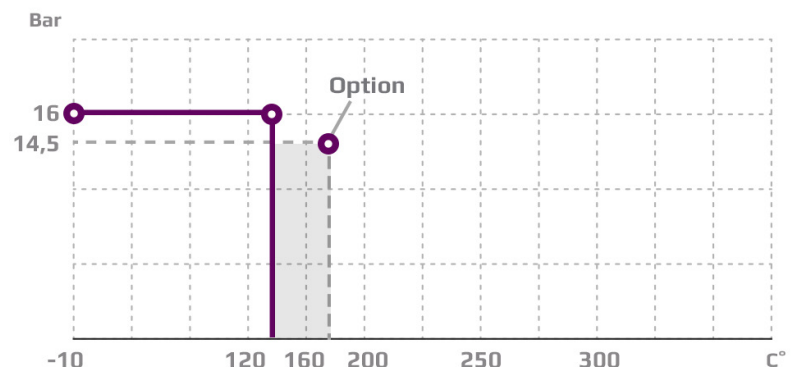

PORT NUMBERING

The ports of valves type H3F are marked with the figures 1, 2 and 3. The letters in parentheses refer to the corresponding internationally adapted designations.

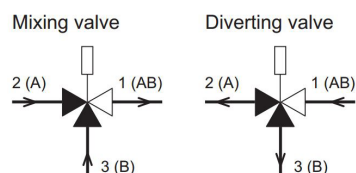

Port 1(AB)
Port 2(A)
Port 3(B)

common port always open
closes at load on spindle
opens at load on spindle



MOUNTING

The valve must always be mounted with vertical spindle, preferable with the motorconnection over the valve. Besides, the valve should be mounted so that the valve motor is exposed to a minimum of moisture and unnecessary vibrations. Free height above/below the valve must be minimum 400 mm for mounting and operating of the AVM/AVF 234 motor, otherwise minimum 745 mm for pneumatic actuators.

DIMENSION SKETCH

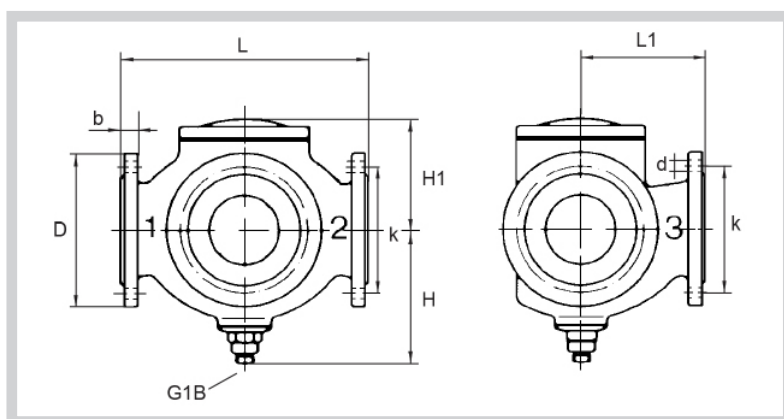

Type	L mm	L1 mm	H mm	H1 mm	D (dia.) mm	b mm	k (dia.) mm	d mm dia. (number)
80 H3F	310	155	180	127	200	19	160	19x(8)
100 H3F	350	175	195	141	220	19	180	19x(8)
125 H3F	400	240	245	171	250	21	210	19x(8)
150 H3F	480	270	280	189	285	22	240	23x(8)

SPECIFICATIONS

Type	Flange connection	Opening mm	Mixing value k_{vs} -value	Diverting value k_{vs} -value	Lifting height (mm)	Weight (kg)
80 H3F	80	80	80	69	11	35
100 H3F	100	100	125	108	13	44
125 H3F	125	125	215	185	18	72
150H3F	150	150	310	267	20	111

3-way Control Valve type H3FA

Cast steel, PN16, DN 80 – 150 mm

0-2.4.20-A

Page 1 of 2



APPLICATIONS

Control valves type H3FA are designed for regulating of fresh water, lubricating oil and other liquid media. The valves are designed for use in conjunction with large industrial processes, district heating and marine installations, e.g. cooling of main and auxiliary engines. Is used in conjunction with Clorius valve motor type AVM/AVF 234 or Clorius pneumatic actuators.

DESIGN

The valve components (seats and cone) are made of alubronze, the spindle of stainless steel. The valve body is made of nodular cast iron and the valve flanges are drilled according to EN 1092-2 (JIS B 2210 option). Tight between port 1(AB) og 3(B) is optional.

FUNCTION

The valve cone is firmly connected with the motor spindle. When the valve cone is in the one extreme position by draw on the spindle, connection A-AB is kept fully open and connection B-AB is fully closed. In the other extreme position connection A-AB is fully closed and connection B-AB is fully open. In the intermediate positions the opening degrees change proportionally.

TECHNICAL DATA

Materials:	
- Valve body	Cast steel GP240GH
- Seats and cone	Alu Bronze
- Spindle	Stainless steel
- O-ring	A75H
- Gasket	Reinz-AFM34
Nominal pressure	PN 16
Seats	2 balanced single seats
Flow characteristic	Almost linear
Leakage rate	≤ 0.5%
Regulating capability	Kvs/Kvr > 25
Flanges According to	EN 1092-2, PN 16
- Option:	According to JIS B 2210 10K
Counter flanges	(suggested for EN 1092-2) DIN 2633 – PN 16

For cooling and heating purposes Important note

In case the valves are applied as diverting valves, the pressure drop will increase by 35% and the kvs-value will decrease by 14% as against mixing valves.

Subject to change without notice.

FEATURES

- Can be used for both mixing and diverting
- Simple design secures reliable controls and reduces costly downtime
- Location of the pack box in the actuator makes the valve service friendly

PRESSURE/TEMPERATURE DIAGRAM

According to DIN 2401

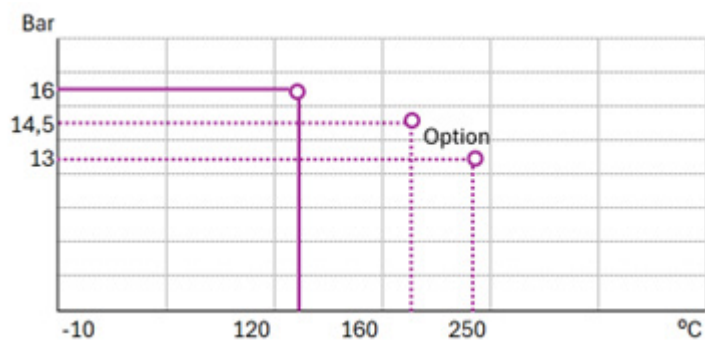

PORT NUMBERING

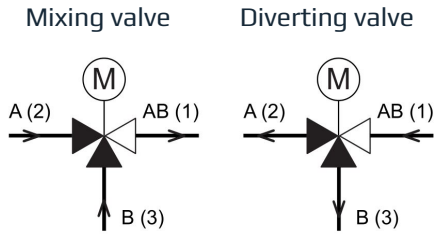

Port AB (1)
Port A (2)
Port B (3)

common port always open
closes at load on spindle
opens at load on spindle



MOUNTING

The valves can be installed vertical as well as horizontal. The valves must be mounted in a way that the valve motor will be exposed to a minimum of moisture and unnecessary vibrations. Free height above / below the valve must be minimum 400 mm for mounting and operation of the AVM/AVF 234 motor, otherwise minimum 745 mm for pneumatic actuators.

DIMENSION SKETCH

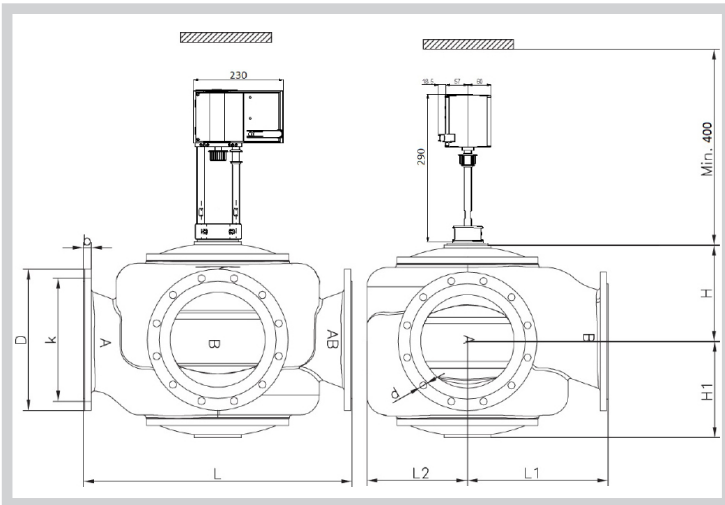

SPECIFICATIONS

Type	Flange connection DN in mm	Opening mm	k_{vs} -value ¹⁾ m ³ /h	Lifting height mm	Weight kg
80 H3FA	80	80	80	11	35
100 H3FA	100	100	125	13	44
125 H3FA	125	125	215	18	72
150 H3FA	150	150	310	20	111

1) The stated kvs values apply for mixing valves.
Diverting valves: 0.86 x (kvs-values for mixing valves).

Type							EN 1092-2			JIS B 2210 10K		
	L mm	L1 mm	L2 mm	H mm	H1 mm	b mm	D (dia.) mm	k (dia.) mm	d mm dia. (num-)	D (dia.) mm	k (dia.) mm	d mm dia. (number)
80 H3FA	310	155	102	117	127	19	200	160	19x(8)	185	150	19x(8)
100 H3FA	350	175	112	132	141	19	220	180	19x(8)	210	175	19x(8)
125 H3FA	400	240	138	181	171	19	250	210	19x(8)	250	210	23x(8)
150 H3FA	480	270	165	216	189	24	285	240	23x(8)	280	240	23x(8)

2-way Control Valve type H2FR

Cast Steel, PN 40, DN 20 – 80 mm, 2 Seats, Reverse acting

0-2.4.09-I

Page 1 of 2



TECHNICAL DATA

Materials:

- Valve body	Cast steel GP240GH (GS-C25)
- Trim	Stainless steel
- Nuts, bolts	24 CrMo 4/A4
- Gasket	Graphite with stainless steel foil and copper
Nominal pressure	PN 40
Seating	Double seated
Flow characteristic	Quadratic
Leakage rate	$\leq 0.5\%$ of Kvs
Regulating capability	Kvs/Kvr > 25

Function	Opens by pressing the spindle
Flanges drilled according to	EN 1092-1 PN 40
Counter flanges	DIN 2635/BS 4504

Reverse acting (normally closed)
For cooling systems or similar
Adjustable seat interspace

APPLICATIONS

Valves type H2FR are mainly intended for control of cooling systems. The valves are used in conjunction with temperature or pressure differential regulators for controlling industrial processes or cooling systems. As the reverse acting valves are held in closed position by means of a built-in spring, the max. differential pressure, Δp_L , against which a valve can close depends on the spring. When opening the valve, the actuator has to overcome the spring force. The table on the next page shows max. allowable values of Δp_L as well as the max. allowable inlet pressures for opening the valves, p_{1max} , for various actuator forces.

DESIGN

The valve components – spindle, seat and cone – are made of stainless steel. The valve body is made of cast steel GP240GH (GS-C25) with flanges drilled according to EN 1092-1. The thread for the actuator connection is G1B ISO 228. The valves are double-seated. The leakage rate is less than 0.5% of the full flow (according to VDI/VDE 2174).

FUNCTION REVERSE ACTING

Without an actuator being connected, the valve is held in closed position by means of a spring. With pressure on the spindle the valve opens. In connection with our actuators, the valves act as “cooling” valves, i.e. they open at rising temperatures. The quadratic characteristic will not cease until the flow has dropped below 4% of the full flow.

FEATURES

- Simple design secures reliable controls
- Location of the pack box in the actuator makes the valve service friendly
- Reliable and secure due to internal parts of stainless steel

PRESSURE/TEMPERATURE DIAGRAM

According to DIN 2401

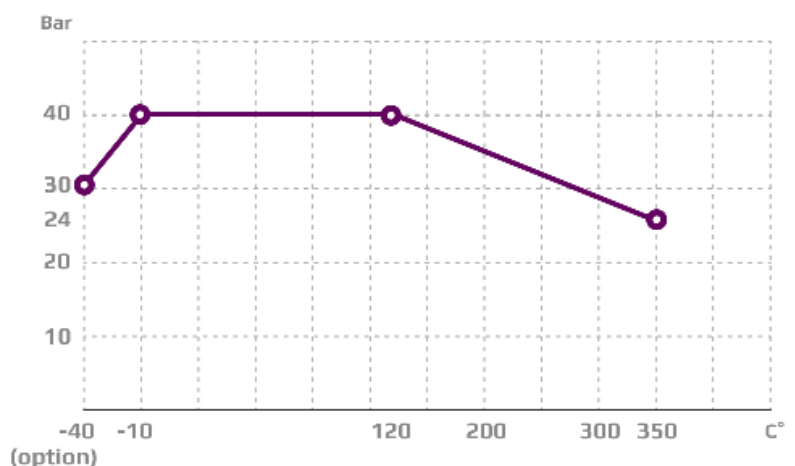

Subject to change without notice.



MOUNTING

The valve can be installed with vertical as well as horizontal spindles. For valve temperatures of max. 170 °C, the thermostat/ actuator can be fitted below or above the valve. For valve mounted with thermostats in media temperatures above 170 °C, a cooling unit has to be applied with connection downwards (please refer to data sheet for thermostat accessories). For electric actuators a high temperature adaptor must be used (please refer to data sheets for the electric actuators).

DIMENSION SKETCH

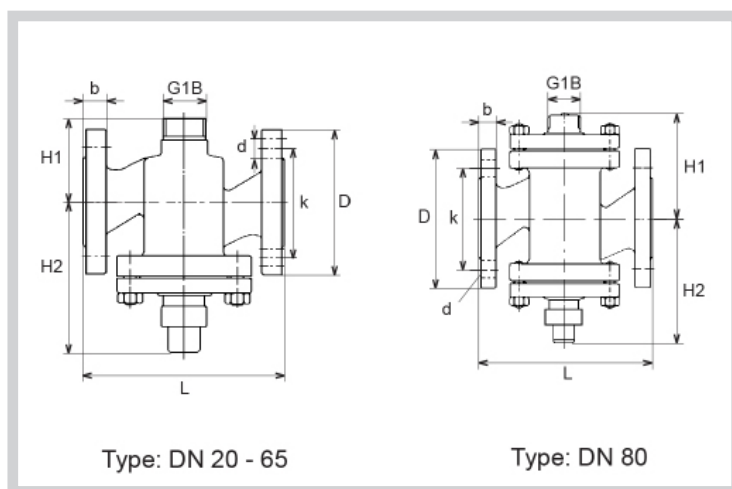

Type	L mm	H1 mm	H2 mm	D (dia.) mm	b mm	k (dia.) mm	d mm dia. (number)
20 H2FR	150	63	112	105	18	75	14x(4)
25 H2FR	160	70	117	115	18	85	14x(4)
32 H2FR	180	75	151	140	18	100	18x(4)
40 H2FR	200	85	155	150	18	110	18x(4)
50 H2FR	230	95	169	165	20	125	18x(4)
65 H2FR	290	110	180	185	22	145	18x(8)
80 H2FR	310	155	195	200	24	160	18x(8)

SPECIFICATIONS

Type	Flange connection Dn in mm	Opening mm	k_{vs} -value m ³ /h	Lifting height mm	Max. Δp_L bar	Actuat. force N	Corresp. p_{1max} bar	Weight kg
20 H2FR	20	20	5	6.5	8.3	200	9.4	5
25 H2FR	25	25	7.5	7	8	200	8.8	6.5
32 H2FR	32	32	12.5	8	7	400	16	9
40 H2FR	40	40	20	9	6.6	400	16	11
50 H2FR	50	50	30	10	5.8	400	15	16
65 H2FR	65	65	50	11	10	400	10	21
80 H2FR	80	80	80	13	6.7	400	10	38

2-way control valve type H2FR

Cast steel, PN 25, DN 100 – 125 mm / PN 16, DN 150 mm, Reverse acting

0-2.4.10-G

Page 1 of 2



APPLICATIONS

Valves type H2FR are mainly intended for control of cooling systems. The valves are used in conjunction with temperature- or pressure differential regulators. As the reverse acting valves are held in closed position by means of a built-in spring, the max. differential pressure, Δp_L , against which a valve can close depends on the spring and when opening the valve, the actuator has to overcome the spring force. On the next page please find the max. allowable values of Δp_L as well as the max. allowable inlet pressures for opening the valves, p_{1max} for various actuator forces.

DESIGN

The valve components - spindle, seats and cone - are made of stainless steel. The valve body is made of cast steel GP240GH (GS-C25) with flanges drilled according to EN 1092-1. The connection thread for the actuator is G1B ISO 228. The valves are double-seated. The leakage rate is less than 0.5% of the full flow (according to VDI/VDE 2174).

FUNCTION

REVERSE ACTING

Without an actuator being connected, the valve is held in closed position by means of a spring. With pressure on the spindle the valve opens. In connection with our actuators, the valves act as "cooling" valves, i.e. they open at rising temperatures. The linear characteristic will not cease until the flow has dropped below 4% of the full flow.

FEATURES

Simple design secures reliable controls

Location of the pack box in the actuator makes the valve service friendly

Reliable and secure due to internal parts of stainless steel

PRESSURE/TEMPERATURE DIAGRAM

According to DIN 2401

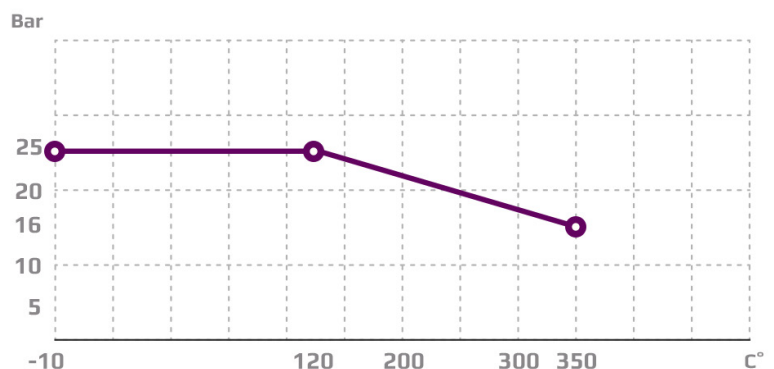

TECHNICAL DATA

Materials:

- Valve body	Cast steel GP240GH (GS-C25)
- Trim	Stainless steel CuSn5Zn5Pb5-C
- Bolts, nuts	24 CrMo 4/A4
- Gasket	Stainless steel foil Copper

Nominal pressure	PN 25
Seating	Double seated
Flow characteristic	Almost quadratic
Function	Opens by pressing the spindle
Leakage rate	$\leq 0.5\%$ of Kvs
Regulating capability	Kvs/Kvr > 25
Flanges	EN 1092-1 PN 25
Counter flanges	DIN 2635/DS625
Reverse acting (normally closed)	
For cooling water and lubrications	

Important note

All Clorius valves are approved in accordance to the Pressure Equipment Directive (PED). Valve type 150 H2FR is only approved for nominal pressure PN 16, but for applications not effected by the PED, valve type 150 H2FR can be delivered for nominal pressure PN 25.

Subject to change without notice.

MOUNTING

The valve can be installed with vertical as well as horizontal spindles. For valve temperatures of max. 170 °C, the thermostat/ actuator can be fitted below or above the valve. For valve mounted with thermostats in media temperatures above 170 °C, a cooling unit has to be applied with connection downwards (please refer to data sheet for thermostat accessories). For electric actuators a high temperature adaptor must be used (please refer to data sheets for the electric actuators).



DIMENSION SKETCH

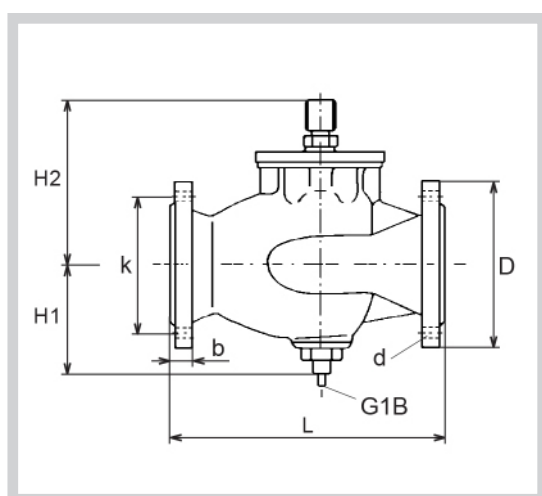

Type	L mm	H1 mm	H2 mm	D (dia.) mm	b mm	k (dia.) mm	d mm dia. (number)
100 M2FR	350	145	240	220	24	190	23x(8)
125 M2FR	400	180	290	250	26	220	27x(8)
150 M2FR	400	180	290	285	28	250	27x(8)

SPECIFICATIONS

Type	Flange connection Dn in mm	Opening mm	k_{vs} -value m ³ /h	Lifting height mm	Max. Δp_L bar	Actuat. force N	Weight kg
100 H2FR	100	100	125	20	12.1	800	39
125 H2FR	125	125	215	20	9	800	73
150 H2FR	150	150	310	20	7.5	800	76

2-way Control Valve type G1F

Nodular cast iron, PN 25, DN 15/4 – 50 mm

0-2.5.02-I

Page 1 of 2

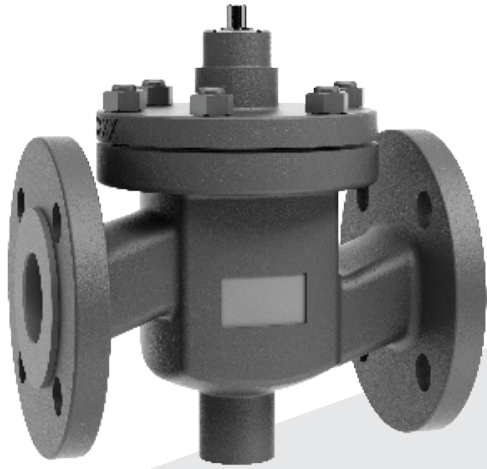

TECHNICAL DATA

Materials:

- Valve body	Nodular cast iron EN-GJS-400-15
- Components	Stainless steel
- Nuts, bolts	24 CrMo 4/A4
- Gasket	Stainless steel foil

Nominal pressure	PN 25
Seating	Single seated
Flow characteristic	Quadratic
Leakage rate	$\leq 0.5\%$ of Kvs
Regulating capability	Kvs/Kvr > 25

Flanges drilled according to	EN 1092-2 or ANSI B16.5 Class 150
Counter flanges	DIN2634

Subject to change without notice.

APPLICATIONS

Control valves type G1F are designed for regulating hot water, steam and hot oil systems. The valves are used in conjunction with our temperature or pressure differential regulators for controlling industrial processes, district or central heating plants or marine installations.

DESIGN

The valve components - spindle, seat and cone - are made of stainless steel. The valve body is made of nodular cast iron EN-GJS-400-15 with flanges drilled according to EN 1092-2 or ANSI B16.5 Class 150. The thread for the actuator connection is G1B ISO 228. The valves are single-seated. The leakage rate is less than 0.05% of the full flow (according to VDI/VDE 2174).

FUNCTION

Without the actuator being connected, the valve is held in open position by means of a spring. With pressure on the spindle the valve will close. In connection with our thermostats, pneumatic or electric actuators, the valves will close at rising temperatures. For cooling circuits the valve can be used in conjunction with a reverse acting electric actuator. Alternatively a reverse acting valve can be used with our self-acting thermostats. The quadratic characteristic will not cease until the flow has dropped below 4% of the full flow.

FEATURES

- Simple design secures reliable controls
- Location of the pack box in the actuator makes the valve service friendly
- Reliable and secure due to internal parts of stainless steel
- Low leakage rate reduces the risk of overheating

PRESSURE/TEMPERATURE DIAGRAM

According to DIN 2401

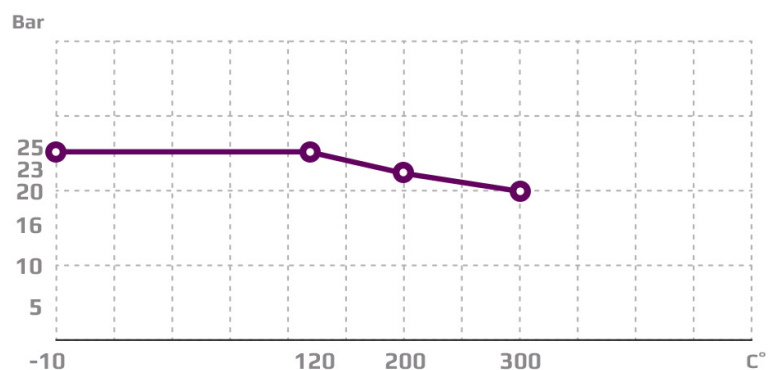

MOUNTING

The valve can be installed with vertical as well as horizontal spindles. For valve temperatures of max. 170 °C, the thermostat/ actuator can be fitted below or above the valve. For valve mounted with thermostats in media temperatures above 170 °C, a cooling unit has to be applied with connection downwards (please refer to data sheet for thermostat accessories). For electric actuators a high temperature adaptor must be used (please refer to data sheets for the electric actuators).



DIMENSION SKETCH

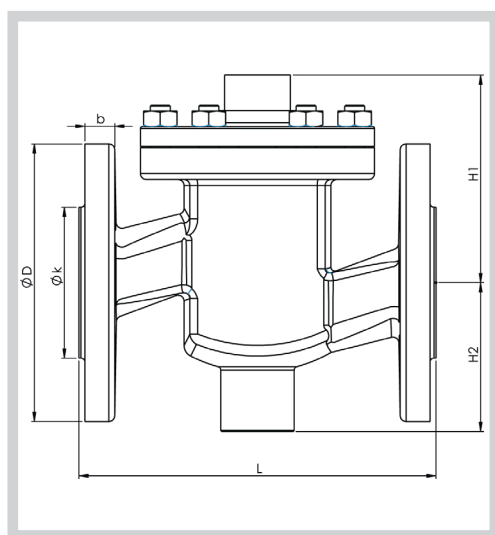

SPECIFICATIONS

Type	Flange connection DN in mm	Opening mm	k_{vs} -value m ³ /h	Lifting height mm	Weight kg
15/4 G1F	15	4	0.20	6	3.0
15/6 G1F	15	6	0.45	6	3.0
15/9 G1F	15	9	0.95	6	3.1
15/12 G1F	15	12	1.7	6	3.1
15 G1F	15	15	2.75	6	3.1
20 G1F	20	20	5	6.5	4.2
25 G1F	25	25	7.5	7	5.5
32 G1F	32	32	12.5	8	8.1
40 G1F	40	40	20	9	9.7
50 G1F	50	50	30	10	14.0

Type	L (mm)	H1 (mm)	H2 (mm)	b (mm)	EN 1092-2			ANSI B16.5 Class 150		
					D (dia.) (mm)	k (dia.) (mm)	d mm dia. (number)	D (dia.) (mm)	k (dia.) (mm)	d mm dia. (number)
15/4 G1F	130	80	60	14	95	65	14x(4)	89	61	16x(4)
15/6 G1F	130	80	60	14	95	65	14x(4)	89	61	16x(4)
15/9 G1F	130	80	60	14	95	65	14x(4)	89	61	16x(4)
15/12 G1F	130	80	60	14	95	65	14x(4)	89	61	16x(4)
15 G1F	130	80	60	14	95	65	14x(4)	89	61	16x(4)
20 G1F	150	85	65	16	105	75	14x(4)	98	70	16x(4)
25 G1F	160	95	70	16	115	85	14x(4)	108	79	16x(4)
32 G1F	180	105	75	18	140	100	18x(4)	118	89	16x(4)
40 G1F	200	110	85	18	150	110	18x(4)	127	98	16x(4)
50 G1F	230	125	95	20	165	125	18x(4)	153	121	19x(4)

Balanced 2-way Control Valve type G1FB

Nodular cast iron, PN 25, DN 25 – 65 mm

0-2.5.03-E

Page 1 of 2



TECHNICAL DATA

Materials:

- Valve body	Nodular cast iron EN-GJS-400-15
- Components	Stainless steel
- Nuts, bolts	24 CrMo 5/A4
- Gasket	Reinz-AFM34 Metal - Copper
- Bellow	Stainless steel W.1.1541

Nominal pressure	PN 25
Seating	Single-seated, tight closing

Flow characteristic Quadratic

Leakage rate $\leq 0.05\%$ of Kvs

Regulating capability Kvs/Kvr > 25

Flanges	EN 1092-2 PN 25
---------	--------------------

Pressure balanced valve

APPLICATIONS

The pressure balanced control valves type G1FB are designed for regulating hot water, steam and hot oil systems. Balanced valves are used in installations where the system pressure necessitates a closing force greater than available in the actuator programme for a standard single seated valve, and where the leakage rate for a double-seated valve is unacceptable.

The valves are used in conjunction with our temperature- or pressure differential regulators for controlling industrial processes, district or central heating plants or marine installations.

DESIGN

The valve components - spindle, seat, cone and bellow - are made of stainless steel. The bellows for balancing the pressure are fitted on the valve spindle which reduces the force necessary for closing the valve, as the upstream pressure of the medium through the hollow valve spindle acts outside and the pressure after the valve acts inside the bellow system. The valve body is made of nodular cast iron EN-GJS-400-15 with flanges drilled according to EN 1092-2. The thread for the actuator connection is G1B ISO 228. The valves are single-seated. The leakage rate is less than 0.05% of the full flow (according to VDI/VDE 2174).

FUNCTION

Without an actuator being connected, the valve is held in open position by means of a spring and the bellow system. With pressure on the spindle the valve will close. In connection with our thermostats, pneumatic or electric actuators, the valves will close at rising temperatures. For cooling circuits the valve can be used in conjunction with a reverse acting electric actuator. Alternatively a reverse acting double seated valve can be used with our self-acting thermostats. The quadratic characteristic will not cease until the flow has dropped below 4% of the full flow.

FEATURES

- Simple design secures reliable controls
- Location of the pack box in the actuator makes the valve service friendly
- Reliable and secure due to internal parts of stainless steel
- Low leakage rate reduces the risk of overheating

PRESSURE/TEMPERATURE DIAGRAM

According to DIN 2401

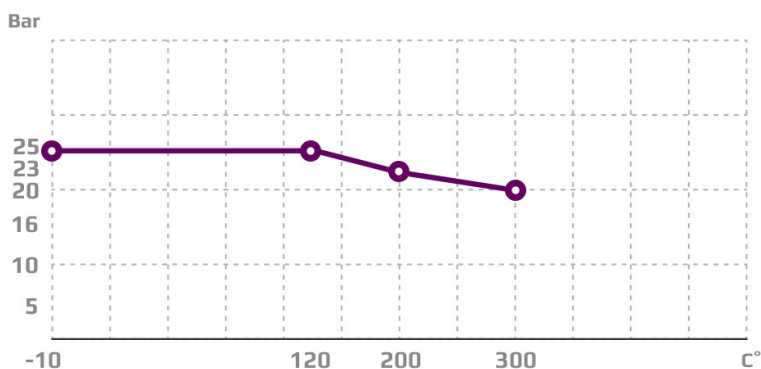

Subject to change without notice.

MOUNTING

The valve can be installed with vertical as well as horizontal spindles. For valve temperatures of max. 170 °C, the thermostat/ actuator can be fitted below or above the valve. For valve mounted with thermostats in media temperatures above 170 °C, a cooling unit has to be applied with connection downwards (please refer to data sheet for thermostat accessories). For electric actuators a high temperature adaptor must be used (please refer to data sheets for the electric actuators).

DIMENSION SKETCH

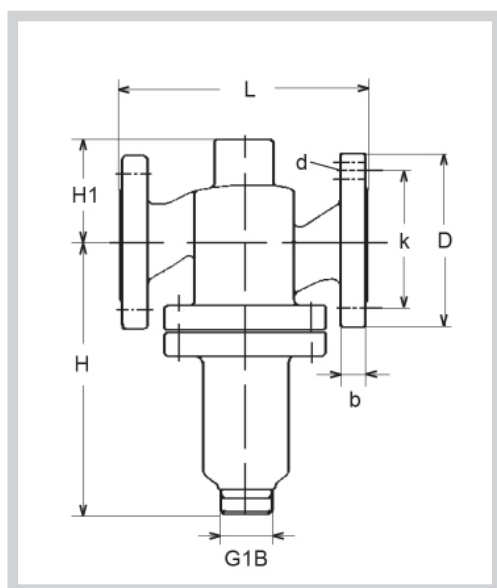

Type	L mm	H mm	H1 mm	D (dia.) mm	b mm	k (dia.) mm	d mm dia. (number)
25 H1FB	160	180	70	115	16	85	14x(4)
32 H1FB	180	195	75	140	18	100	18x(4)
40 H1FB	200	205	85	150	19	110	18x(4)
50 H1FB	230	225	95	165	19	125	18x(4)
65 H1FB	290	260	110	185	19	145	18x(8)

SPECIFICATIONS

Type	Flange connection	Opening (mm)	k_{vs} -value m^3/h	Lifting height (mm)	Weight (kg)
25 G1FB	25	25	7.5	7	6
32 G1FB	32	32	12.5	8	9
40 G1FB	40	40	20	9	13
50 G1FB	50	50	30	10	16
65 G1FB	65	65	50	13	23

Balanced 2-way Control Valve type G1FBN

Nodular cast iron, PN 25, DN 15 – 80 mm

0-2.5.03.01-H

Page 1 of 2



TECHNICAL DATA

Materials:

- Valve body	Nodular cast iron EN-GJS-400-15
- Components	Stainless steel
- Nuts, bolts	24 CrMo 5/A4
- Gasket	Stainless steel foil
- O-ring	A75H FEPM 75 CO

Nominal pressure	PN 25
Seating	Single-seated, balanced

Flow characteristic	Quadratic
Leakage rate	$\leq 0,05\%$ of Kvs
Regulating capability	Kvs/Kvr > 25

Flanges drilled according to	EN 1092-2 PN 25 or ANSI B16.5 Class 150
------------------------------	-----------------------------------------------

Pressure balanced valve

APPLICATIONS

Balanced control valves type G1FBN are designed for regulating hot water, steam and hot oil systems. Balanced valves are used in installations where the system pressure necessitates a closing force greater than available in the actuator programme for a standard single seated valve, and where the leakage rate for a double-seated valve is unacceptable. The valves are used in conjunction with our temperature or pressure differential regulators for controlling industrial processes, district or central heating plants or marine installations.

DESIGN

The valve components - spindle, seat, cone - are made of stainless steel. The valve body is made of nodular cast iron EN-GJS-400-15 with flanges drilled according to EN 1092-2 or ANSI B16.5 Class 150. The thread for the actuator connection is G1B ISO 228. The valves are single-seated. The leakage rate is less than 0.05% of the full flow (according to VDI/VDE 2174).

FUNCTION

Without an actuator being connected, the valve is held in open position by means of a spring. With force on the spindle the valve will close. In connection with our thermostats, pneumatic or electric actuators, the valves will close at rising temperatures. For cooling circuits the valve can be used in conjunction with a reverse acting electric actuator. Alternatively a reverse acting double seated valve can be used with our self-acting thermostats. The quadratic characteristic will not cease until the flow has dropped below 4% of the full flow.

FEATURE

- Simple design secures reliable controls
- Location of the pack box in the actuator makes the valve service friendly
- Reliable and secure due to internal parts of stainless steel
- Low leakage rate reduces the risk of overheating

PRESSURE/TEMPERATURE DIAGRAM

According to DIN 2401

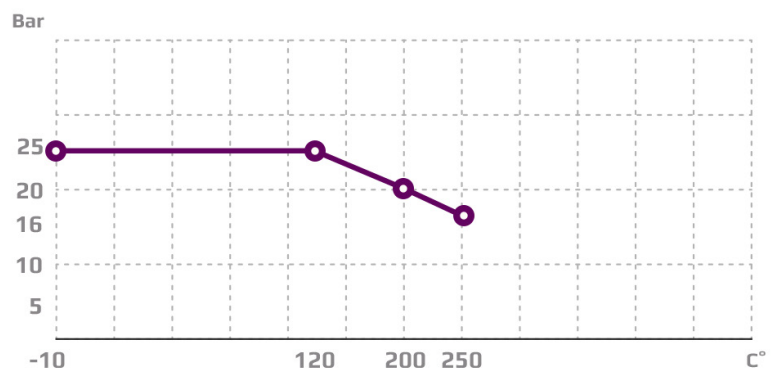

Subject to change without notice.

MOUNTING

The valve can be installed with vertical as well as horizontal spindles. For valve temperatures of max. 170 °C, the thermostat/ actuator can be fitted below or above the valve. For valve mounted with thermostats in media temperatures above 170 °C, a cooling unit has to be applied with connection downwards (please refer to data sheet for thermostat accessories). For electric actuators a high temperature adaptor must be used (please refer to data sheets for the electric actuators).



DIMENSION SKETCH

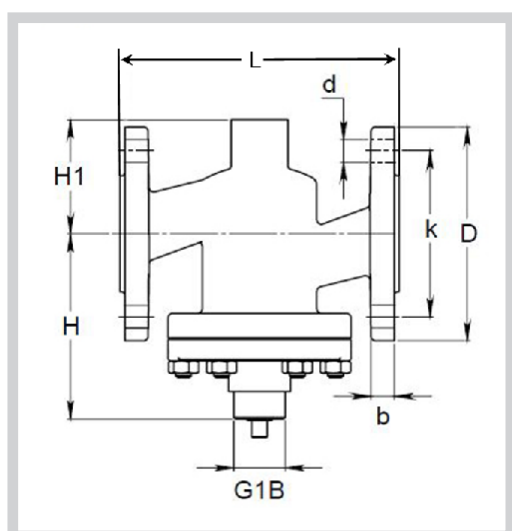

Type	L mm	H mm	H1 mm	D (dia.) mm	b mm	k (dia.) mm	d mm dia. (number)
15 G1FBN	130	101	80	95	14	65	14x(4)
20 G1FBN	150	107	85	105	16	75	14x(4)
25 G1FBN	160	112	70	115	16	85	14x(4)
32 G1FBN	180	122	75	140	18	100	18x(4)
40 G1FBN	200	125	85	150	19	110	18x(4)
50 G1FBN	230	140	95	165	19	125	18x(4)
65 G1FBN	290	154	110	185	19	145	18x(4)
80 G1FBN	310	164	115	200	19	160	19x(8)

SPECIFICATIONS

Type	Flange connection DN in mm	Opening mm	k_{vs} -value m^3/h	Lifting height mm	Weight kg
15 G1FBN	15	15	4	7.5	4
20 G1FBN	20	20	6.3	7.5	5
25 G1FBN	25	25	10	9	6
32 G1FBN	32	32	16	10	9
40 G1FBN	40	40	25	11	13
50 G1FBN	50	50	35	11.5	16
65 G1FBN	65	65	58	14.5	23
80 G1FBN	80	80	80	16	38

2-way Control Valve type H1FBE

Nodular cast iron, Single seat balanced, PN 25, DN 200 - 250 mm, Flanged ends

0-2.5.03.02-B

Page 1 of 2



TECHNICAL DATA

Materials:

- Valve body	Nodular cast iron
	EN-GJS-400-15
- Spring	1.4568
- Cone	1.4408, 1.4305
- Gasket	TFM and PVMQ
- Bolts, Nuts	4 CrMo 4/A4
Nominal pressure	PN 25
Seating	Single seated balanced
Flow characteristic	Equal percentage
Leakage rate	≤ 0.01% of Kvs Class IV
Regulating capability	Kvs/Kvr > 25

Flanges drilled according to

EN 1092-2 PN 25
(ANSI)
(JIS)

Counter flanges

DIN2634

Adjustable seat interspace

APPLICATIONS

Control valves type H1FBE are designed for regulating steam and hot water systems. The valves are used in conjunction with our temperature or pressure regulators for controlling industrial processes, district or central heating plants or marine installations.

DESIGN

The valve components - spindle, seat and cone - are made of stainless steel. The valve body is made of nodular cast iron EN-GJS-400-15 with flanges drilled according to EN 1092-2. The leakage rate is 0.01% Class IV of the full flow (according to VDI/VDE 2174)

FUNCTION

With pressure on the spindle the valve will close. Because of the balanced plug, the closing force is pressure independent. In connection with our pneumatic or electric actuators, the valves will close at rising temperatures. For cooling circuits the valve can be used in conjunction with a reverse acting electric actuator or positioner. The equal percentage characteristic will not cease, until the flow has dropped below 4% of the full flow.

FEATURES

- Simple design secures reliable controls
- Location of the pack box in the actuator makes the valve service friendly
- Easy maintenance
- Hand wheel for manual override

PRESSURE/TEMPERATURE DIAGRAM

According to DIN 2401

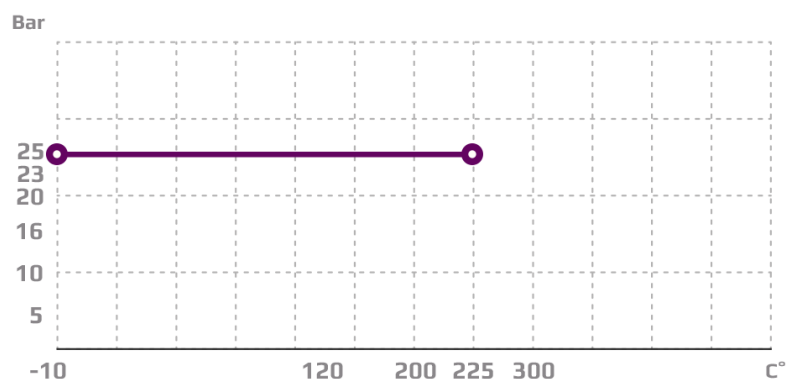

Subject to change without notice.

MOUNTING

The valve can be installed with vertical as well as horizontal spindles.

CHARACTERISTICS

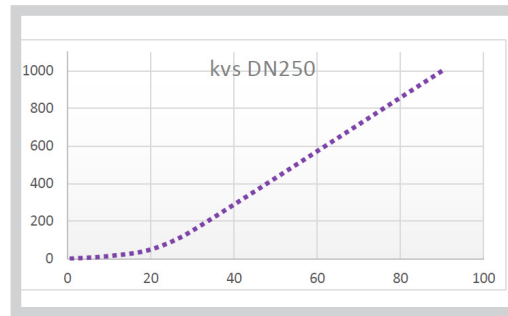
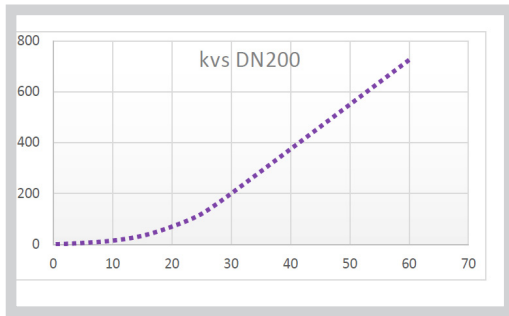

DIMENSION SKETCH

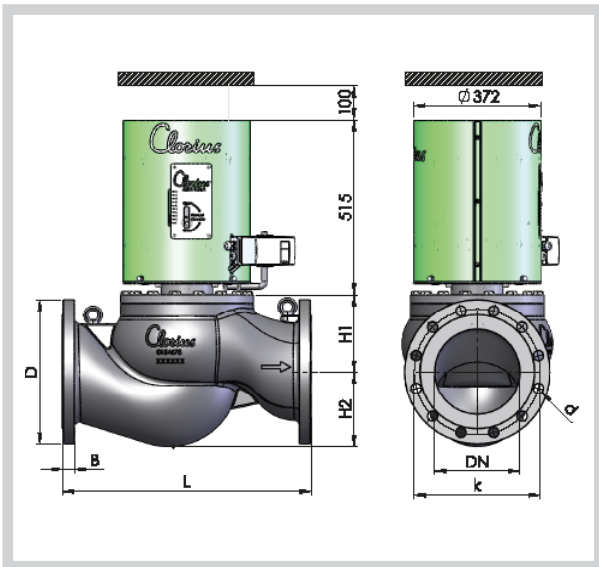

Type	L (mm)	H1 (mm)	H2 (mm)	D (dia.) (mm)	b (mm)	k (dia.) (mm)	d mm dia. (number)
200 G1F	600	238	180	360	32	310	12xØ26
250 G1F	730	227	220	425	35	370	12xØ30

SPECIFICATIONS

Type	Flange connection DN in mm	Opening mm	k _{vs} -value m ³ /h	Lifting height mm	Weight kg
200 G1F	DIN1092 PN25	200	725	80	220*
250 G1F	DIN1092 PN25	250	1000	95	258*

*including actuator

2-way Control Valve type G1FBE

Nodular cast iron, Single seat balanced, PN 25, DN 200 - 300 mm, Flanged ends

0-2.5.04.02-A

Page 1 of 2



TECHNICAL DATA

Materials:

- Valve body	Nodular cast iron
	EN-GJS-400-15
- Spring	1.4568
- Cone	1.4408, 1.4305
- Gasket	TFM and PVMQ
- Bolts, Nuts	4 CrMo 4/A4
Nominal pressure	PN 25
Seating	Single seated balanced
Flow characteristic	Equal percentage
Leakage rate	$\leq 0.01\%$ of Kvs Class IV
Regulating capability	Kvs/Kvr > 25

Flanges drilled according to

EN 1092-2 PN 25
(ANSI)
(JIS)

Counter flanges

DIN2634

Adjustable seat interspace

APPLICATIONS

Control valves type G1FBE are designed for regulating steam and hot water systems. The valves are used in conjunction with our temperature or pressure regulators for controlling industrial processes, district or central heating plants or marine installations.

DESIGN

The valve components - spindle, seat and cone - are made of stainless steel. The valve body is made of nodular cast iron EN-GJS-400-15 with flanges drilled according to EN 1092-2. The leakage rate is 0.01% Class IV of the full flow (according to VDI/VDE 2174)

FUNCTION

With pressure on the spindle the valve will close. Because of the balanced plug, the closing force is pressure independent. In connection with our pneumatic or electric actuators, the valves will close at rising temperatures. For cooling circuits the valve can be used in conjunction with a reverse acting electric actuator or positioner. The equal percentage characteristic will not cease, until the flow has dropped below 4% of the full flow.

FEATURE

- Simple design secures reliable controls
- Location of the pack box in the actuator makes the valve service friendly
- Easy maintenance
- Hand wheel for manual override

PRESSURE/TEMPERATURE DIAGRAM

According to DIN 2401

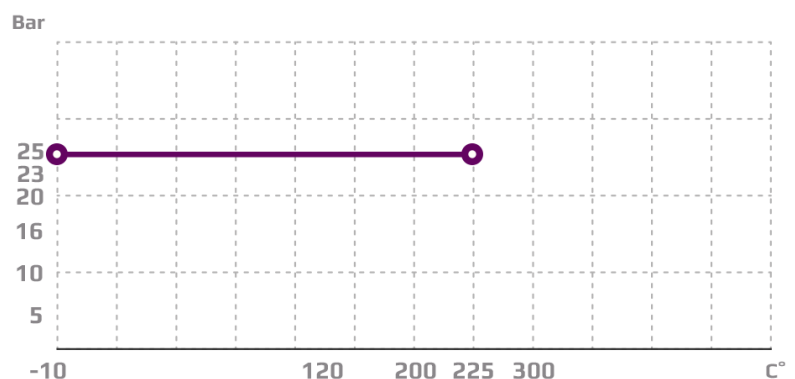

Subject to change without notice.

MOUNTING

The valve can be installed with vertical as well as horizontal spindles.

CHARACTERISTICS

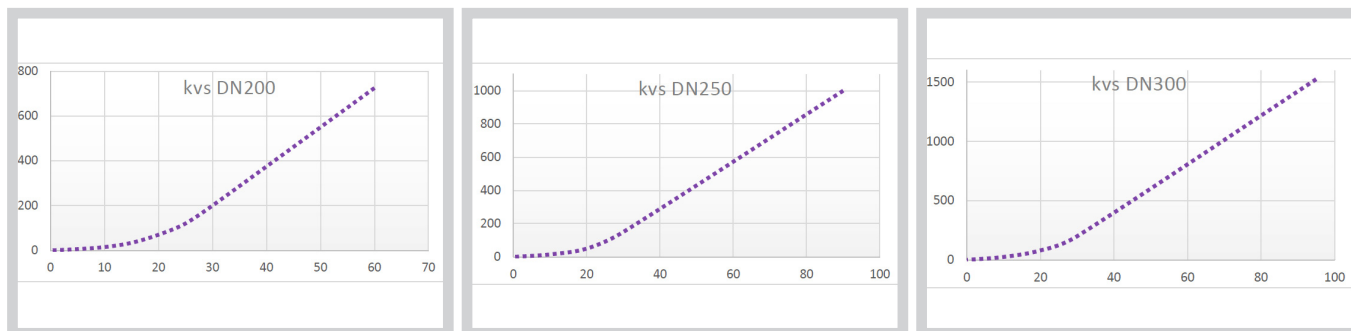

DIMENSION SKETCH

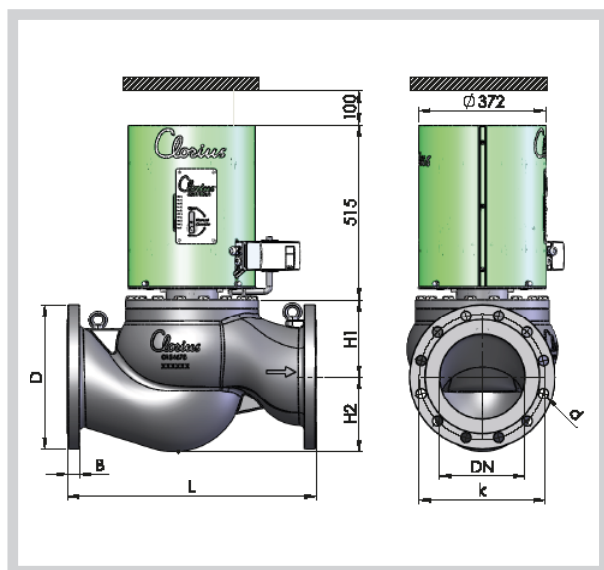

Type	L (mm)	H1 (mm)	H2 (mm)	D (dia.) (mm)	b (mm)	k (dia.) (mm)	d mm dia. (number)
200 G1F	600	238	180	360	32	310	12xø26
250 G1F	730	227	220	425	35	370	12xø30
300 G1F	850	301	250	485	38	430	16xø30

SPECIFICATIONS

Type	Flange connection DN in mm	Opening mm	k_{vs} -value m ³ /h	Lifting height mm	Weight kg
200 G1F	DIN1092 PN25	200	725	80	220*
250 G1F	DIN1092 PN25	250	1000	95	258*
300 G1F	DIN1092 PN25	300	1500	95	370*

*including actuator

2-way Control Valve type G2F

Nodular cast iron, 2 seats, PN 25, DN 20 – 80 mm, Flanged ends

0-2.5.04-F

Page 1 of 2



TECHNICAL DATA

Materials:

- Valve body	Nodular cast iron EN-GJS-400-15
- Spring	1.4568
- Cone	1.4408, 1.4305
- Gasket	Stainless steel foil and graphite
- Upper seat	AISI 303
- Lower seat	1.4301, 1.4305, 1.4307
- Bolts, nuts	24 CrMo 4/A4
Nominal pressure	PN 25
Seating	Double seated
Flow characteristic	Quadratic
Leakage rate	$\leq 0.5\%$ of Kvs
Regulating capability	Kvs/Kvr > 25

Flanges drilled according to	EN 1092-2 PN 25
Counter flanges	DIN 2634
Adjustable seat interspace	

APPLICATIONS

Control valves type G2F are designed for regulating hot water, steam and hot oil systems. The double-seated valves are used in installations where the system pressure necessitates a closing force greater than available in the actuator programme for a single-seated valve. The valves are used in conjunction with our temperature or pressure differential regulators for controlling industrial processes, district or central heating plants or marine installations.

DESIGN

The valve components - spindle, seats and cone - are made of stainless steel. The valve body is made of nodular cast iron EN-GJS-400-15 with flanges drilled according to EN 1092-2. The thread for the actuator connection is G1B ISO 228. The valves are double-seated. The leakage rate is less than 0.5% of the full flow (according to VDI/VDE 2174).

FUNCTION

Without the actuator being connected, the valve is held in open position by means of a spring. With pressure on the spindle the valve will close. In connection with our thermostats, pneumatic or electric actuators, the valves will close at rising temperatures. For cooling circuits the valve can be used in conjunction with a reverse acting electric actuator. Alternatively a reverse acting valve can be used with our self-acting thermostats. The quadratic characteristic will not cease, until the flow has dropped below 4% of the full flow.

FEATURES

- Simple design secures reliable controls
- Location of the pack box in the actuator makes the valve service friendly
- Reliable and secure due to internal parts of stainless steel

PRESSURE/TEMPERATURE DIAGRAM

According to DIN 2401

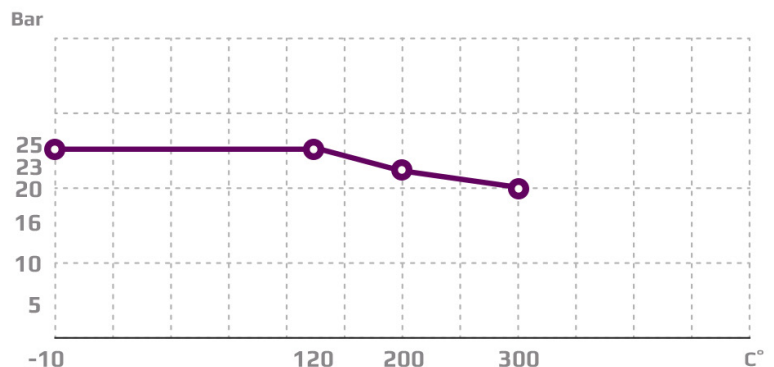

Subject to change without notice.



MOUNTING

The valve can be installed with vertical as well as horizontal spindles. For valve temperatures of max. 170 °C, the thermostat/ actuator can be fitted below or above the valve. For valve mounted with thermostats in media temperatures above 170 °C, a cooling unit has to be applied with connection downwards (please refer to data sheet for thermostat accessories). For electric actuators a high temperature adaptor must be used (please refer to data sheets for the electric actuators).

DIMENSION SKETCH

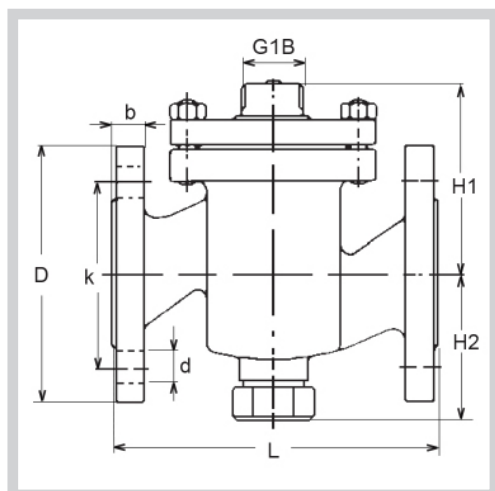

Type	L mm	H1 mm	H2 mm	D (dia.) mm	b mm	k (dia.) mm	d mm dia. (number)
20 G2F	150	85	70	105	16	75	14x(4)
25 G2F	160	95	77	115	16	85	14x(4)
32 G2F	180	105	82	140	18	100	19x(4)
40 G2F	200	110	92	150	19	110	19x(4)
50 G2F	230	125	102	165	19	125	19x(4)
65 G2F	290	135	120	185	19	145	19x(4)
80 G2F	310	145	130	200	19	160	19x(8)

SPECIFICATIONS

Type	Flange connection DN in mm	Opening mm	k_{vs} -value m^3/h	Lifting height mm	Weight kg
20 G2F	20	20	5	6.5	5
25 G2F	25	25	7.5	7	6.5
32 G2F	32	32	12.5	8	9
40 G2F	40	40	20	9	11
50 G2F	50	50	30	10	16
65 G2F	65	65	50	11	21
80 G2F	80	80	80	13	38

2-way Control Valve type G2F

Nodular cast iron, PN 16, DN 100 – 150 mm

0-2.5.05-D

Page 1 of 2



TECHNICAL DATA

Materials:

- Valve body	Nodular cast iron EN-GJS-400-15
- Components	Stainless steel
- Nuts, bolts	24 CrMo 5/A4
- Gasket	Stainless steel foil - Copper

Nominal pressure

PN 16

Seating

Double seated

Flow characteristic

Almost quadratic

Function

Closing with pressure
on spindle

Leakage rate

$\leq 0.5\%$ of Kvs

Regulating capability

Kvs/Kvr > 25

Flanges drilled

EN 1092-2

according to

DIN 2633

Counter flanges

Subject to change without notice.

APPLICATIONS

Control valves type G2F are designed for use in regulating high pressure hot water, steam and heat transfer oil. The valves are used in conjunction with temperature or pressure differential regulators for controlling district or central heating plants, industrial processes or marine installations.

DESIGN

The valve components – spindle, seats and cone – are made of stainless steel. The valve body is made of nodular cast iron EN-GJS-400-15 with flanges drilled according to EN 1092-2. The connection thread for the actuator is G1B ISO 228. The valves are double-seated. The leakage rate is less than 0.5% of the full flow (according to VDI/VDE 2174).

FUNCTION

Without the actuator being connected, the valve is held in open position by means of a spring. With pressure on the spindle the valve will close. In connection with our thermostats, pneumatic or electric actuators, the valves will close at rising temperatures. For cooling circuits the valve can be used in conjunction with a reverse acting electric actuator. Alternatively a reverse acting valve can be used with our self-acting thermostats. The quadratic characteristic will not cease, until the flow has dropped below 4% of the full flow.

FEATURES

- Simple design secures reliable controls
- Location of the pack box in the actuator makes the valve service friendly
- Reliable and secure due to internal parts of stainless steel

PRESSURE/TEMPERATURE DIAGRAM

According to DIN 2401

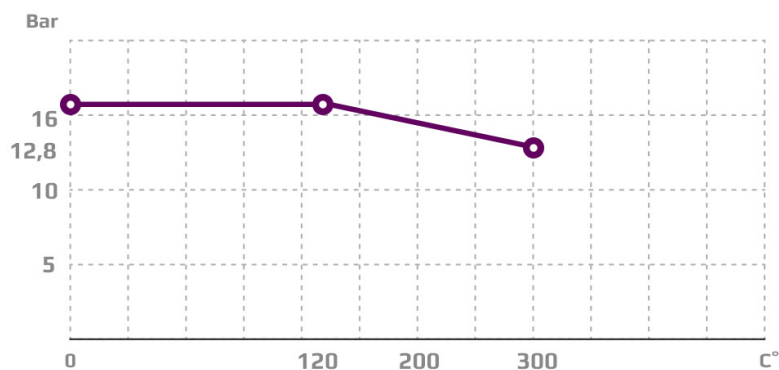



MOUNTING

The valve can be installed with vertical as well as horizontal spindles. For valve temperatures of max. 170 °C, the thermostat/ actuator can be fitted below or above the valve. For valve mounted with thermostats in media temperatures above 170 °C, a cooling unit has to be applied with connection downwards (please refer to data sheet for thermostat accessories). For electric actuators a high temperature adaptor must be used (please refer to data sheets for the electric actuators).

DIMENSION SKETCH

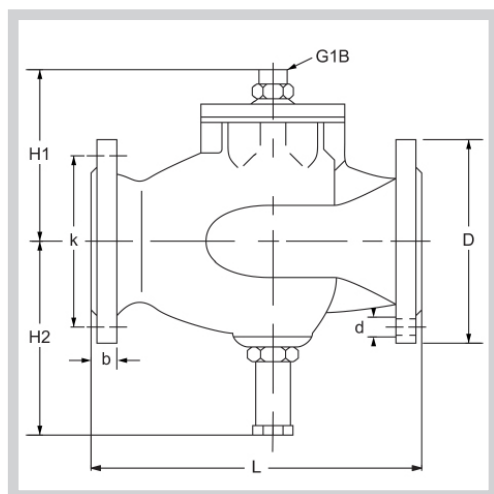

Type	L mm	H1 mm	H2 mm	D (dia.) mm	b mm	k (dia.) mm	d mm dia. (number)
100 G2F	350	185	209	220	19	180	19x(8)
125 G2F	400	205	224	250	19	210	19x(8)
150 G2F	400	240	244	285	19	240	23x(8)

SPECIFICATIONS

Type	Flange connection DN in mm	Opening mm	k_{vs} -value m^3/h	Lifting height mm	Weight kg
100 G2F	100	100	125	20	32
125 G2F	125	125	215	20	50
150 G2F	150	150	310	20	70

2-way Control Valve type G2FM-T

Nodular cast iron PN 25, DN 65-125 mm / PN 16, DN 150 – 300 / PN 10, DN 350 – 600 mm

0-2.5.05.01-E

Page 1 of 4



APPLICATIONS

Control valve type G2FM-T is a two-way control valve with blocked port making a two-way control valve. The slide for quarter turn operation designed for regulating of fresh water, lubricating oil and other liquid media. The valves are designed for use in conjunction with industrial processes, district heating and marine installations with large water or lubricating oil quantities. The valves are designed for use in conjunction with valve motor type CAR-H with handle for manual operation or for use in conjunction with a pneumatic actuator.

DESIGN

The valve body and the valve slide are made of nodular cast iron. The valve flanges are drilled according to EN 1092-2 or ANSI Class 150.

FUNCTION

The slide is firmly connected with the motor spindle. When the slide is in the one extreme position by turning the spindle, connection A-AB is kept fully open. In the other extreme position connection the valve is fully closed. In the intermediate positions the opening degrees change proportionally. The valve has a small tolerance between body and slide. To minimize the leakage an O-ring is mounted in a groove on the slide.

TECHNICAL DATA

Materials:	
- Valve body, slide	Nodular cast iron EN-GJS-400-15
- O-ring	NBR 70A
- Nuts, bolts	24 CrMo 5/A4
- U-ring	PTFE
Nominal pressure	
- DN 65-125	PN 25, max. 100°C (option 250°C)
- DN 150-300	PN 16, max. 100°C (option 250°C)
- DN 350-600	PN 10, max. 100°C (option 250°C)
Flow characteristic	Almost linear
Leakage rate	Max. 0.5%
Regulating capability	Kvs/Kvr > 25
Flanges	
	EN 1092-2 PN 10/16/25
Counter flanges (suggested)	
	ANSI Class 150 DIN 2632 – PN 10 DIN 2633 – PN 16 DIN 2634 – PN 25
Max. pressure Δp_L, against which the control can close:	
- DN 65-125	25 bar
- DN 150-300	16 bar
- DN 350-600	10 bar

FEATURES

- Simple design secures reliable controls and reduces costly downtime
- Low leakage rate secures energy savings and avoids overheating

PRESSURE/TEMPERATURE DIAGRAM

According to DIN 2401

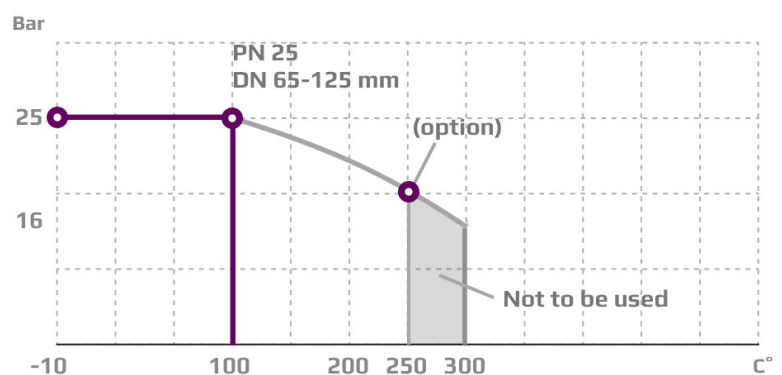

PRESSURE/TEMPERATURE DIAGRAM

According to DIN 2401

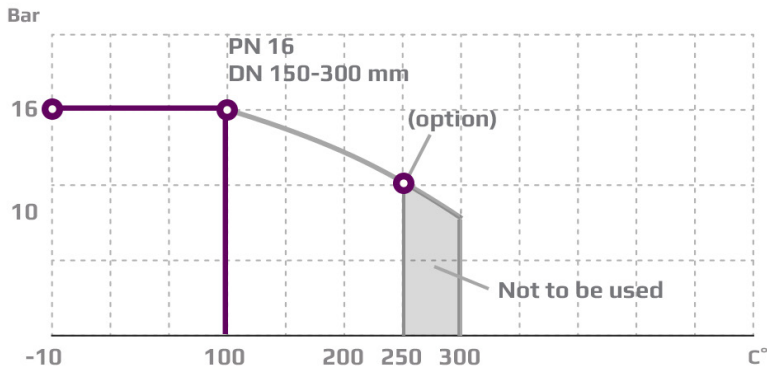

* DN125 available on request in PN16

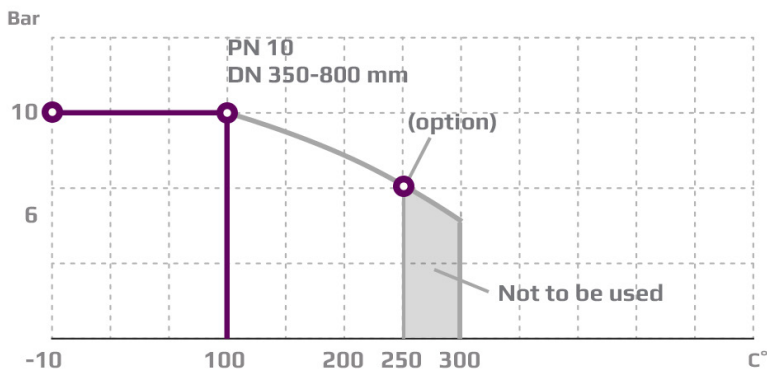

PORT NUMBERING

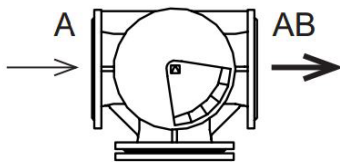

MOUNTING

The valve connections are marked A and AB. Check slide position before installation of the valve. The slide position is marked on the top of the shaft. The valve can be installed with vertical as well as horizontal spindles. The valve must be mounted in a way that the valve actuator will be exposed to a minimum of moisture and unnecessary vibrations.

2-way Control Valve type G2FM-T

Nodular cast iron PN 25, DN 65-125 mm / PN 16, DN 150 – 300 / PN 10, DN 350 – 600 mm

0-2.5.05.01-E

Page 3 of 4

DIMENSION SKETCH

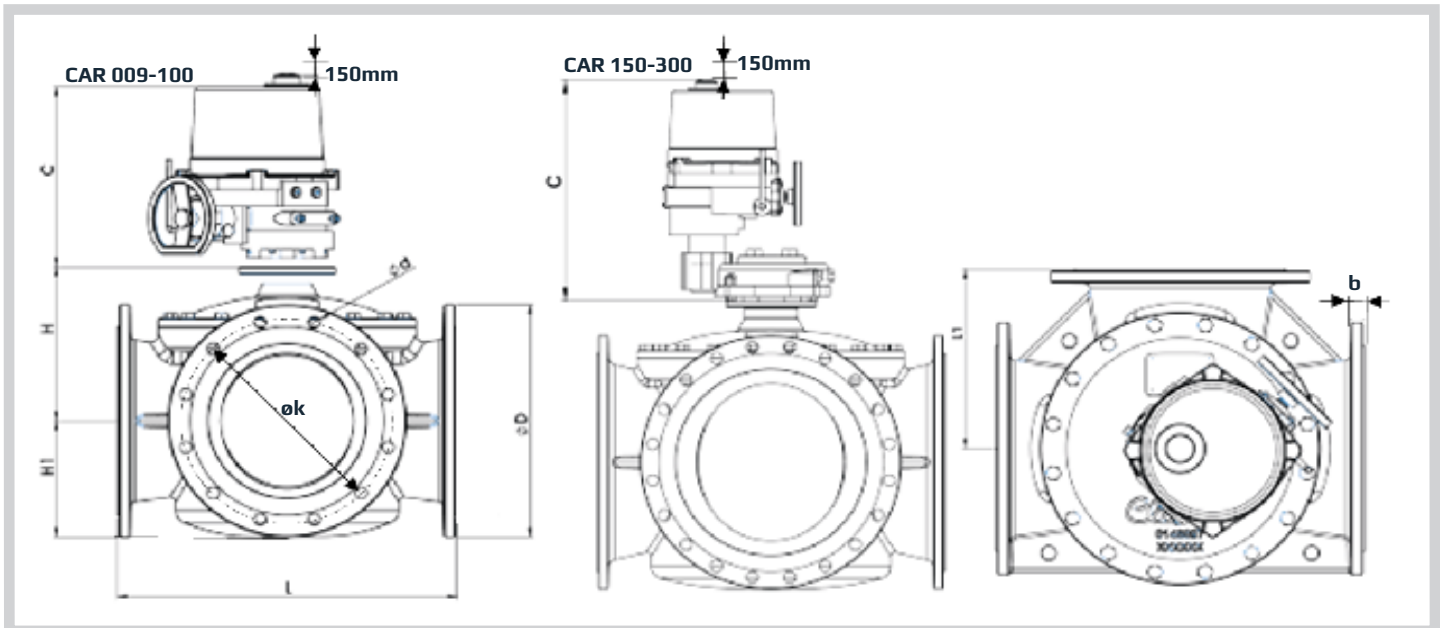

Type	L (mm)	L1 (mm)	H (mm)	H1 (mm)	b (mm)	C (mm)	EN 1092-2			ANSI Class 150			JIS B 2210 5K			JIS B 2210 10K		
							D (dia.) (mm)	k (dia.) (mm)	d mm dia. (number)	D (dia.) (mm)	k (dia.) (mm)	d mm dia. (number)	D (dia.) (mm)	k (dia.) (mm)	d mm dia. (number)	D (dia.) (mm)	k (dia.) (mm)	d mm dia. (number)
65 G3FM-TR	292	146	135	92	19	273	185	145	19x(8)	180	140	19x(4)	155	130	15x(4)	175	140	19x(4)
80 G3FM-TR	292	146	140	94	20	273	200	160	19x(8)	190	152	19x(4)	180	145	19x(4)	185	150	19x(8)
100 G3FM-TR	350	175	158	112	17	273	235	190	23x(8)	230	190.9	19x(8)	200	165	19x(8)	210	175	19x(8)
125 G3FM-TR	400	200	179	123	19	273	270	220	28x(8)	255	216	22x(8)	235	200	19x(8)	250	210	23x(8)
150 G3FM-TR	437	218.5	196	139	19	276	285	240	23x(8)	280	241	22x(8)	265	230	19x(8)	280	240	23x(8)
200 G3FM-TR	530	265	232	169	20	361	340	295	23x(12)	343	299	23x(8)	320	280	23x(8)	320	290	23x(12)
250 G3FM-TR	592	296	272	199	22	361	400	355	28x(12)	407	362	26x(12)	385	345	23x(12)	400	355	25x(12)
300 G3FM-TR	649	324.5	302	227	25	361	455	410	28x(12)	483	432	26x(12)	430	390	23x(12)	445	400	25x(16)
350 G3FM-TR	717	358.5	334.5	251.5	25	361	505	460	23x(16)	534	477	29x(12)	480	435	25x(12)	490	445	25x(16)
400 G3FM-TR	770	385	370	282	25	361	565	515	28x(16)	597	540	29x(16)	540	495	25x(16)	560	510	27x(16)
450 G3FM-TR	820	410	391	307	26	556	615	565	28x(20)	635	578	32x(16)	605	555	25x(16)	620	565	27x(20)
500 G3FM-TR	900	450	421	335	27	556	670	620	28x(20)	699	635	32x(20)	655	605	25x(20)	675	620	27x(20)
550 G3FM-TR	900	450	421	335	27	556	-	-	-	-	-	-	720	665	27x(20)	745	680	33x(20)
600 G3FM-TR	918	459	470	354	31	556	780	725	31x(20)	813	750	35x(20)	770	715	25x(20)	795	730	33x(24)
650 G3FM-TR	1050	525	534	426	37	556	-	-	-	-	-	-	825	770	27x(24)	845	780	33x(24)
800 G3FM-TR	1230	615	596	461	53	556	1085	990	34x(24) 50x(24) PN25	-	-	-	995	930	33x(24)	1020	950	33x(28)

SPECIFICATIONS

Type	Flange connection DN in mm	k_{vs} -value m^3/h	Torque Nm For inlet P*	Weight kg
65 G2FM-T	65	120	60	37
80 G2FM-T	80	154	65	41
100 G2FM-T	100	220	120	56
125 G2FM-T	125	330	200	73
150 G2FM-T	150	425	200	84
200 G2FM-T	200	1100	330	153
250 G2FM-T	250	2100	525	215
300 G2FM-T	300	2650	730	277
350 G2FM-T	350	3380	980	340
400 G2FM-T	400	3950	1370	459
450 G2FM-T	450	4480	1550	579
500 G2FM-T	500	5250	1920	744
550 G2FM-T	550	5250	1920	1090
600 G2FM-T	600	6050	2950	950
800 G2FM-T	800	8000	4000	2100

*Torque calculated at max inlet P for:

DN 65 - 125 = 25 Bar

DN 150-300 = 16 Bar

DN 350-800 = 10 Bar

1

2-way Control Valve type G2FA

Nodular cast iron, PN 16, DN 200 mm / PN 10, DN 300/250 – 300 mm

0-2.5.05.03-A

Page 1 of 2



APPLICATIONS

Regulating valve type G2FA is designed for regulating of fresh water, lubricating oil and other liquid media. The valves are designed for use in conjunction with large industrial processes, district heating and marine installations. G2FA is used in conjunction with Clorius valve motor type AVM/AVF 234 or Clorius pneumatic actuators.

DESIGN

The valve components (seats and cone) are made of alu bronze, the spindle of stainless steel. The valve body is made of nodular cast iron and the valve flanges are drilled according to EN 1092-2.

FUNCTION

The valve cone is firmly connected with the motor spindle. The valves will close at rising temperatures. For cooling circuits the valve can be used in conjunction with a reverse acting electric actuator. The linear characteristic will not cease, until the flow has dropped below 4% of the full flow.

TECHNICAL DATA

Materials:	
- Valve body	Cast iron EN-GJS-400-15
- Trim	Alu Bronze CuAL10Fe5Ni5
- Valve spindle	Stainless steel (W.no. 1.4436)
- O-ring	AFLAS A75H
- Gasket	Reinz-AFM34

Nominal pressure	
- 200 G2FA	PN 16 (max. 120/160°C)
- 300/250-300 G2FA	PN 10 (max. 120/160°C)

Seating	Double seated
Leakage rate	≤ 0.5%
Regulating capability	Kvs/Kvr > 25

Flow characteristic	Almost linear
Flanges according to	EN 1092-2 PN 16 & PN 10

Note! 300/250 G2FA has outer measures and flanges drilled as a 300 G2FA

Counter flanges:	
- 200 G2FA	DIN 2633 - PN 16
- 300/250-300 G2FA	DIN 2632 - PN 10

Subject to change without notice.

FEATURES

- Simple design secures reliable controls
- Location of the pack box in the actuator makes the valve service friendly
- Reliable and secure due to internal parts of stainless steel

PRESSURE/TEMPERATURE DIAGRAM

According to DIN 2401

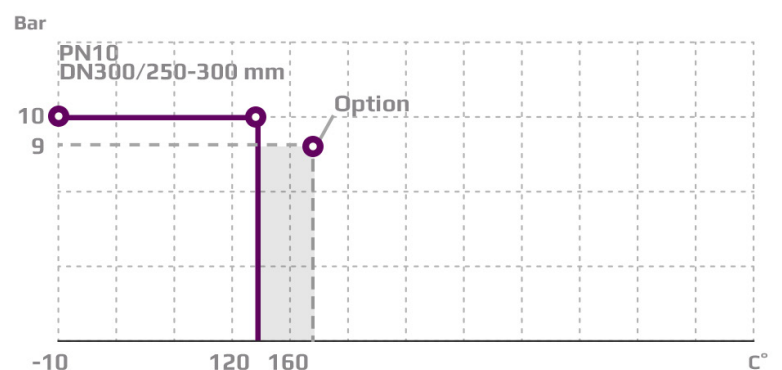
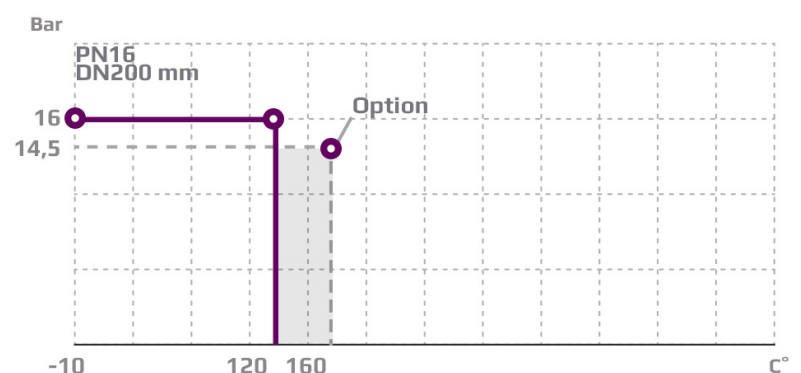

MOUNTING

The valves can be installed with vertical as well as horizontal spindles. The valves must be mounted in a way that the valve motor will be exposed to a minimum of moisture and unnecessary vibrations. Free height above / below the valve must be minimum 400 mm for mounting and operation of the AFM 234 or AVF234 motor. See drawing.

DIMENSION SKETCH

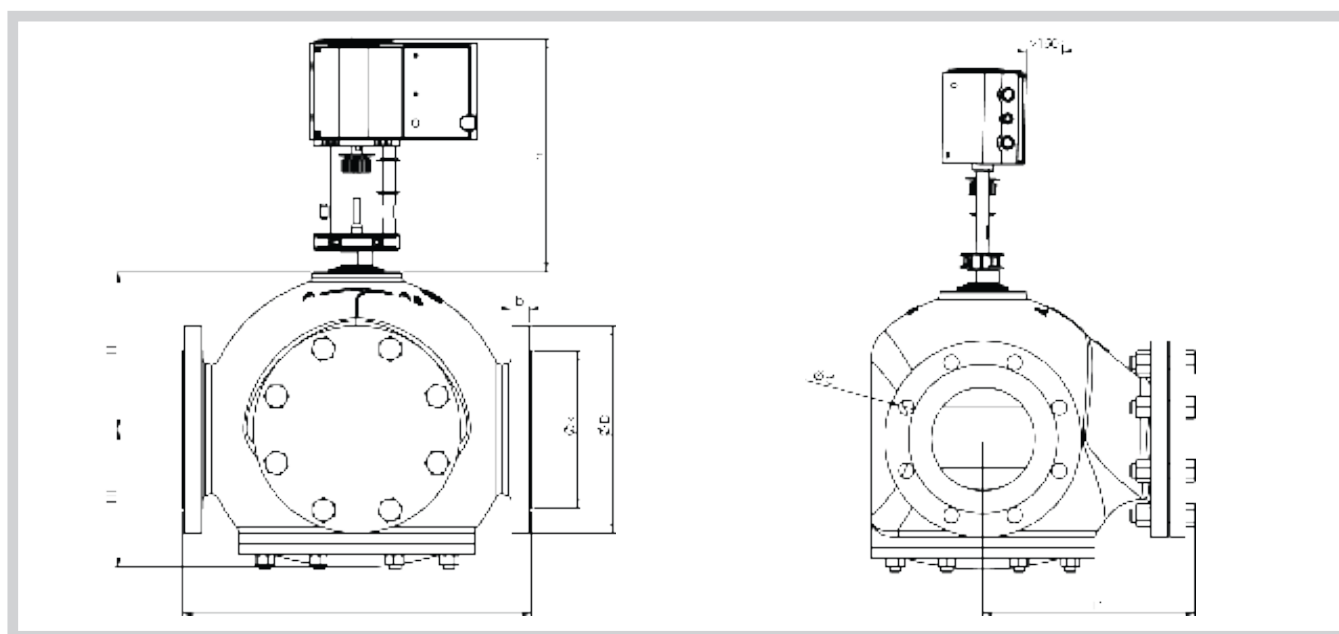

Type	L mm	L1 mm	H mm	H1 mm	b mm	D (dia.) mm	k (dia.) mm	d mm dia. (number)
200 G2FA	600	380	238	238	26	340	295	22x(8)
300/250 G2FA ¹⁾	850	510	305	305	28	445	400	23x(12)
300 G2FA	850	510	305	305	28	445	400	23x(12)

1) Valve type 300/250 G2FA has outer measures and flanges drilled as type 300 G2FA.

SPECIFICATIONS

Type	Flange connection DN in mm	Opening mm	k_{vs} -value m ³ /h	Lifting height mm	Weight kg
200 G2FA	200	200	555	28	160
300/250 G2FA ¹⁾	300	300	865	28	311
300 G2FA	300	300	1250	45	300

1) Valve type 300/250 G2FA has outer measures and flanges drilled as type 300 G2FA.

2-way Control Valve type G2FR

Nodular cast iron, PN 25, DN 20 – 80 mm, Reverse acting

0-2.5.06-F

Page 1 of 2



TECHNICAL DATA

Materials:

- Valve body	Nodular cast iron EN-GJS-400-15
- Trim	Stainless steel
- Nuts, bolts	24 CrMo 5/A4
- Gasket	Graphite with stainless steel foil - Copper

Nominal pressure	PN 25
Seating	Double seated
Flow characteristic	Quadratic
Function	Opens by pressing the spindle
Leakage rate	$\leq 0.5\%$ of Kvs
Regulating capability	Kvs/Kvr > 25

Flanges	EN 1092-2 PN 25
Counter flanges:	DIN 2634

Reverse acting (normally closed)
For cooling systems or similar
Adjustable seats

APPLICATIONS

Valves type G2FR are mainly intended for control of cooling systems. The valves are used in conjunction with temperature or pressure differential regulators. As the reverse acting valves are held in closed position by means of a built-in spring, the max. differential pressure, Δp_L , against which a valve can close depends on the spring and when opening the valve, the actuator has to overcome the spring force. On the next page please find the max. allowable values of Δp_L as well as the max. allowable inlet pressures for opening the valves, p_{1max} , for various actuator forces.

DESIGN

The valve components - spindle, seats and cone - are made of stainless steel. The valve body is made of nodular cast iron EN-GJS-400-15 with flanges according to EN 1092-2. The thread for the actuator connection is G1B ISO 228. The valves are double-seated. The leakage rate is less than 0.5% of the full flow (according to VDI/VDE 2174).

FUNCTION

Without an actuator being connected, the valve is held in closed position by means of a spring. With pressure on the spindle the valve opens. In connection with our actuators, the valves act as "cooling" valves, i.e. they open at rising temperatures. The quadratic characteristic will not cease until the flow has dropped below 4% of the full flow.

FEATURES

- Simple design secures reliable controls
- Location of the pack box in the actuator makes the valve service friendly
- Reliable and secure due to internal parts of stainless steel

PRESSURE/TEMPERATURE DIAGRAM

According to DIN 2401

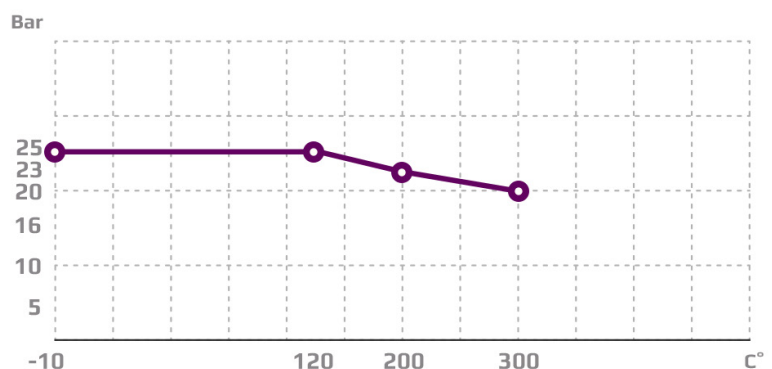

Subject to change without notice.

MOUNTING

The valve can be installed with vertical as well as horizontal spindles. For valve temperatures of max. 170 °C, the thermostat/ actuator can be fitted below or above the valve. For valve mounted with thermostats in media temperatures above 170 °C, a cooling unit has to be applied with connection downwards (please refer to data sheet for thermostat accessories). For electric actuators a high temperature adaptor must be used (please refer to data sheets for the electric actuators).



DIMENSION SKETCH

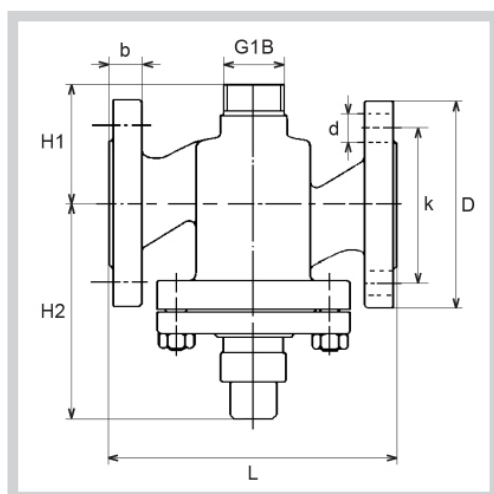

Type	L mm	H1 mm	H2 mm	D (dia.) mm	b mm	k (dia.) mm	d mm dia. (number)
20 G2FR	150	63	112	105	16	75	14x(4)
25 G2FR	160	70	117	115	16	85	14x(4)
32 G2FR	180	75	151	140	18	100	19x(4)
40 G2FR	200	85	155	150	19	110	19x(4)
50 G2FR	230	95	169	165	19	125	19x(4)
65 G2FR	290	110	180	185	19	145	19x(4)
80 G2FR	310	120	180	200	19	160	19x(8)

SPECIFICATIONS

Type	Flange connection Dn in mm	Opening mm	k_{vs} -value m ³ /h	Lifting height mm	Max. Δp_L bar	Actuat. force N	Corresp. p_{1max} bar	Weight kg
20 G2FR	20	20	5	6.5	8.3	200 400	9.4 25	5
25 G2FR	25	25	7.5	7	8	200 400	8.8 25	6.5
32 G2FR	32	32	12.5	8	7	400	27	9
40 G2FR	40	40	20	9	6.6	400	26	11
50 G2FR	50	50	30	10	5.8	400	15	16
65 G2FR	65	65	50	11	10	400 800	10 16	21
80 G2FR	80	80	80	13	6.7	400 800	10 16	38

2-way Control Valve type G2FMT-SL

Nodular cast iron, PN10, DN100 - 400 mm

0-2.5.31-A

Page 1 of 4

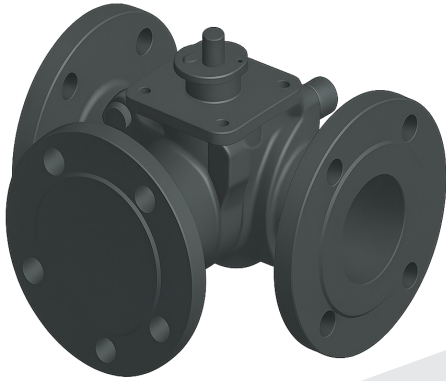

APPLICATIONS

Control valve type G2FMT-SL is a two way control valve with a slide for quarter turn operation designed for regulating of fresh water, lubricating oil and other liquid media. The valves are designed for use in conjunction with industrial processes, district heating and marine installations with large water or lubricating oil volumes:

- Engine Jacket Cooling Water System
- Lubricating Oil Cooling
- Central Cooling Water System, etc.

The valves are designed for use in conjunction with valve motor type CAR-H with handle for manual operation or for use in conjunction with a pneumatic actuator type VT.

DESIGN

The valve body and the valve slide are made of nodular cast iron. The valve flanges are drilled according to EN 1092-2 - option JIS B 2210 5K/10k and ANSI class 150.

FUNCTION

The slide is firmly connected with the motor spindle. When the slide is in the one extreme position by turning the spindle, connection A-AB is kept fully open. In the other extreme position connection the valve is fully closed. In the intermediate positions the opening degrees change proportionally. The valve has a small tolerance between body and slide.

This section to be read together with sketches page 2 this data sheet.

TECHNICAL DATA

Materials:	
- Valve body, slide	Nodular cast iron EN-GJS-400-15
- Sealing element and O-ring	Silicone/PTFE
Flow characteristic	Almost linear
Leakage rate	ANSI class I
Flanges	EN 1092-2 PN 10
- Option	JIS B 2210 5K/10K ANSI class 150
Max. pressure Δp, against which the valve can close	5 bar
Nominal pressure	PN 10
Design temperature	120°C

FEATURES

- Simple design secures reliable controls and reduces costly downtime
- Most compact valve on the market

Subject to change without notice.

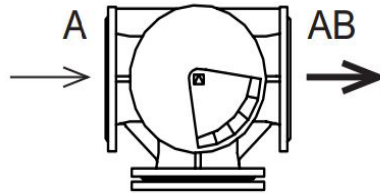
PORT NUMBERING**MOUNTING**

The valve connections are marked A and AB. Check slide position before installation of the valve. The slide position is marked on the top of the shaft. The valve can be installed with vertical as well as horizontal spindles. The valve must be mounted in a way that the valve actuator will be exposed to a minimum of moisture and unnecessary vibrations.

2-way Control Valve type G2FMT-SL

Nodular cast iron, PN10, DN80 - 400 mm

O-2.5.31-A

Page 3 of 4

DIMENSION SKETCH

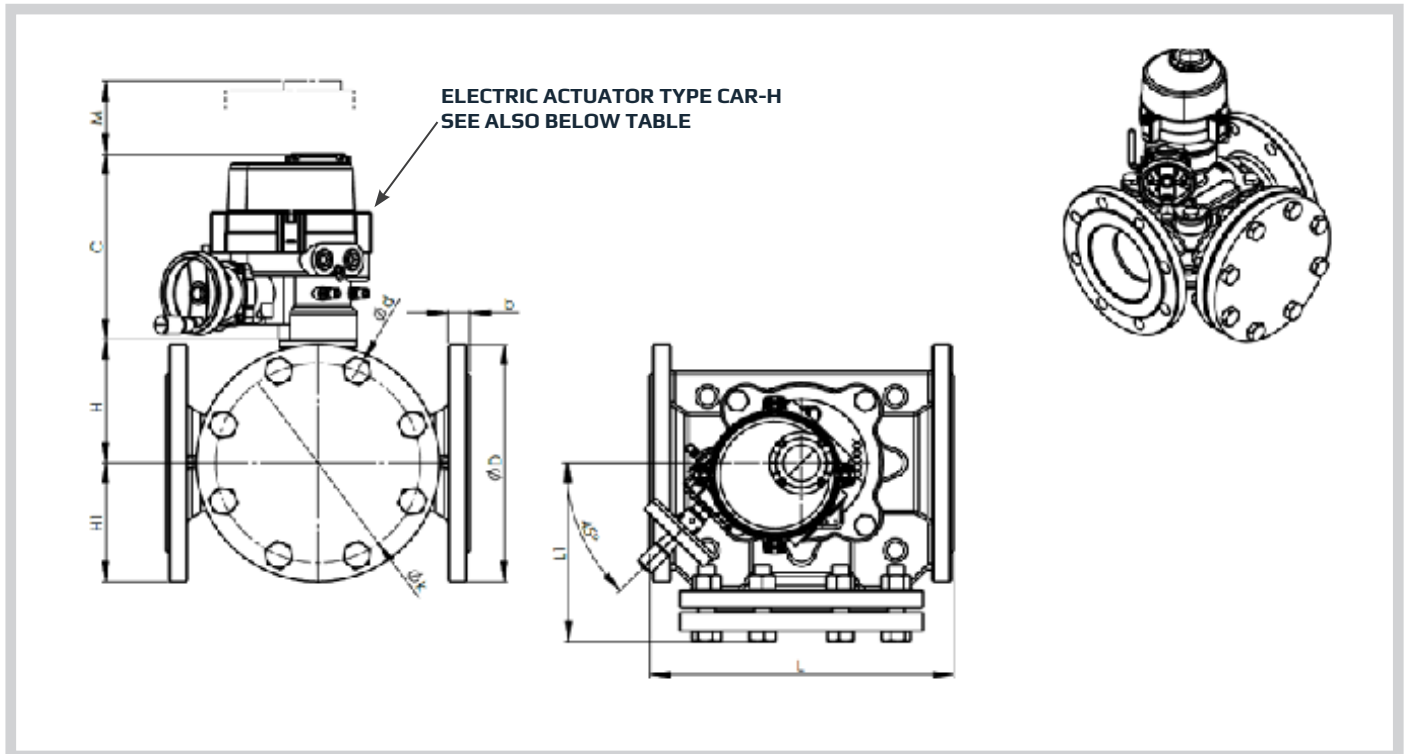

SPECIFICATIONS - TABLE 1 (read this together with table on page 4)

Type	L (mm)	L1 (mm)	H (mm)	H1 (mm)	b (mm)	C1 (mm)	M (mm)	Electric Actuator Type CAR-H
100 G2FMT-SL (*HF)	296	180	140	ØD/2	24	223	110	CAR-H 006/010
125 G2FMT-SL	330	199	140	ØD/2	24	223	110	CAR-H 006/010
125 G2FMT-SL (JIS5K)	320	194	140	ØD/2	19	223	110	CAR-H 006/010
150 G2FMT-SL	356	214,5	149	ØD/2	25,4	223	110	CAR-H 006/010
200 G2FMT-SL	410	243,5	182	ØD/2	28,4	223	110	CAR-H 016
200 G2FMT-SL (**L)	484	280,5	182	ØD/2	28,4	223	110	CAR-H -016
250 G2FMT-SL	480	280,5	202	ØD/2	31	223	110	CAR-H -016
300 G2FMT-SL (**RF)	580	330,5	202	ØD/2	32	223	110	CAR-H 016
300 G2FMT-SL	560	320,5	237	ØD/2	32	261	150	CAR-H -035
350 G2FMT-SL	660	370,5	256	ØD/2	36	261	150	CAR-H 050
400 G2FMT-SL	720	403	278	ØD/2	38	315	180	CAR-H 050

* High Flow
 ** Long Version
 *** Reduced Flow

ØD/2 - Depends on flange type (see also table 2)

SPECIFICATIONS - TABLE 2

Flange connections	EN 1092-2			ANSI Class 150			JIS B 2210 5K			JIS B 2210 10K		
	D (dia.) (mm)	k (dia.) (mm)	d mm dia. (number)	D (dia.) (mm)	k (dia.) (mm)	d mm dia. (number)	D (dia.) (mm)	k (dia.) (mm)	d mm dia. (number)	D (dia.) (mm)	k (dia.) (mm)	d mm dia. (number)
DN100	220	180	19x(8)	230	191	19x(8)	200	165	19x(8)	210	175	19x(8)
DN125	250	210	19x(8)	255	216	22x(8)	235	200	19x(8)	250	210	23x(8)
DN150	285	240	23x(8)	280	241	22x(8)	265	230	19x(8)	280	240	23x(8)
DN200	343	295	22x(8)	343	298	22x(8)	320	280	23x(8)	330	290	23x(12)
DN250	405	350	23x(12)	405	362	25x(12)	385	345	23x(12)	400	355	25x(12)
DN300	455	400	23x(12)	483	432	25x(12)	430	390	23x(12)	445	400	25x(16)
DN350	505	460	23x(16)	533	476	29x(12)	480	435	25x(12)	490	445	25x(16)
DN400	565	515	28x(16)	597	540	29x(16)	540	495	25x(16)	560	510	27x(16)

SPECIFICATIONS - TABLE 3

Type	Flange connection	Kv5 m ³ /h	Torque Nm	Weight kg
DN100 (*HF)	100	259	40	32
DN125	125	259	40	43
DN125 (JIS5K)	125	259	40	43
DN150	150	430	90	53
DN200	200	770	120	85
DN200 (**L)	200	770	120	85
DN250	250	1.230	150	122
DN300 (**RF)	300	1.190	150	174
DN300	300	2.090	320	162
DN350	350	2.950	418	215 (estimated)
DN400	400	3.760	530	269 (estimated)

*Torque calculated at max Δ P for: DN100 - 300 - 5 Bar

* High Flow

** Long Version

*** Reduced Flow

2-way Control Valve type G2FMT-ULL (Ultra Low Leakage)

Nodular cast iron, PN10, DN100 - 400 mm

0-2.5.30-A

Page 1 of 4

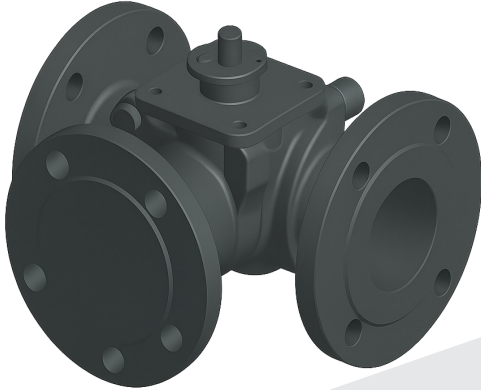

APPLICATIONS

Control valve type G2FMT-ULL is a two way control valve with a slide for quarter turn operation designed for regulating of fresh water, lubricating oil and other liquid media. The valves are designed for use in conjunction with industrial processes, district heating and marine installations with large water or lubricating oil volumes:

- Engine Jacket Cooling Water System
- Lubricating Oil Cooling
- Central Cooling Water System, etc.

The valves are designed for use in conjunction with valve motor type CAR -H with handle for manual operation or for use in conjunction with a pneumatic actuator type VT.

DESIGN

The valve body and the valve slide are made of nodular cast iron. The valve flanges are drilled according to EN 1092-2 - option JIS B 2210 5K/10K and ANSI class 150.

FUNCTION

The slide is firmly connected with the motor spindle. When the slide is in the one extreme position by turning the spindle, connection A-AB is kept fully open. In the other extreme position connection the valve is fully closed. In the intermediate positions the opening degrees change proportionally. The valve has a small tolerance between body and slide. PTFE sealing element and O-ring are mounted in the slider groove to minimize leakage.

This section to be read together with sketches page 2 this data sheet.

TECHNICAL DATA

Materials:	
- Valve body, slide	Nodular cast iron EN-GJS-400-15
- Sealing element and O-ring	Silicone/PTFE
Flow characteristic	Almost linear
Leakage rate	ANSI class IV/EN 1349 < 0.01%
Flanges	EN 1092-2 PN 10
- Option	JIS B 2210 5K/10K ANSI class 150
Max. pressure Δp, against which the valve can close	5 bar
Nominal pressure	PN 10
Design temperature	120°C
Optional temperature	150°C

FEATURES

- **Simple design secures reliable controls and reduces costly downtime**
- **Ultra Low Leakage rate secures energy savings - Best in class**
- **Most compact valve on the market**

Subject to change without notice.

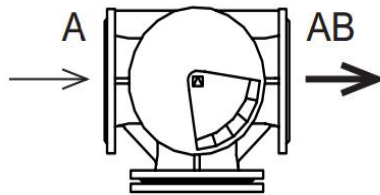
PORT NUMBERING**MOUNTING**

The valve connections are marked A and AB. Check slide position before installation of the valve. The slide position is marked on the top of the shaft. The valve can be installed with vertical as well as horizontal spindles. The valve must be mounted in a way that the valve actuator will be exposed to a minimum of moisture and unnecessary vibrations.

2-way Control Valve type G2FMT-ULL (Ultra Low Leakage)

Nodular cast iron, PN10, DN100 - 400 mm

0-2.5.30-A

Page 3 of 4

DIMENSION SKETCH

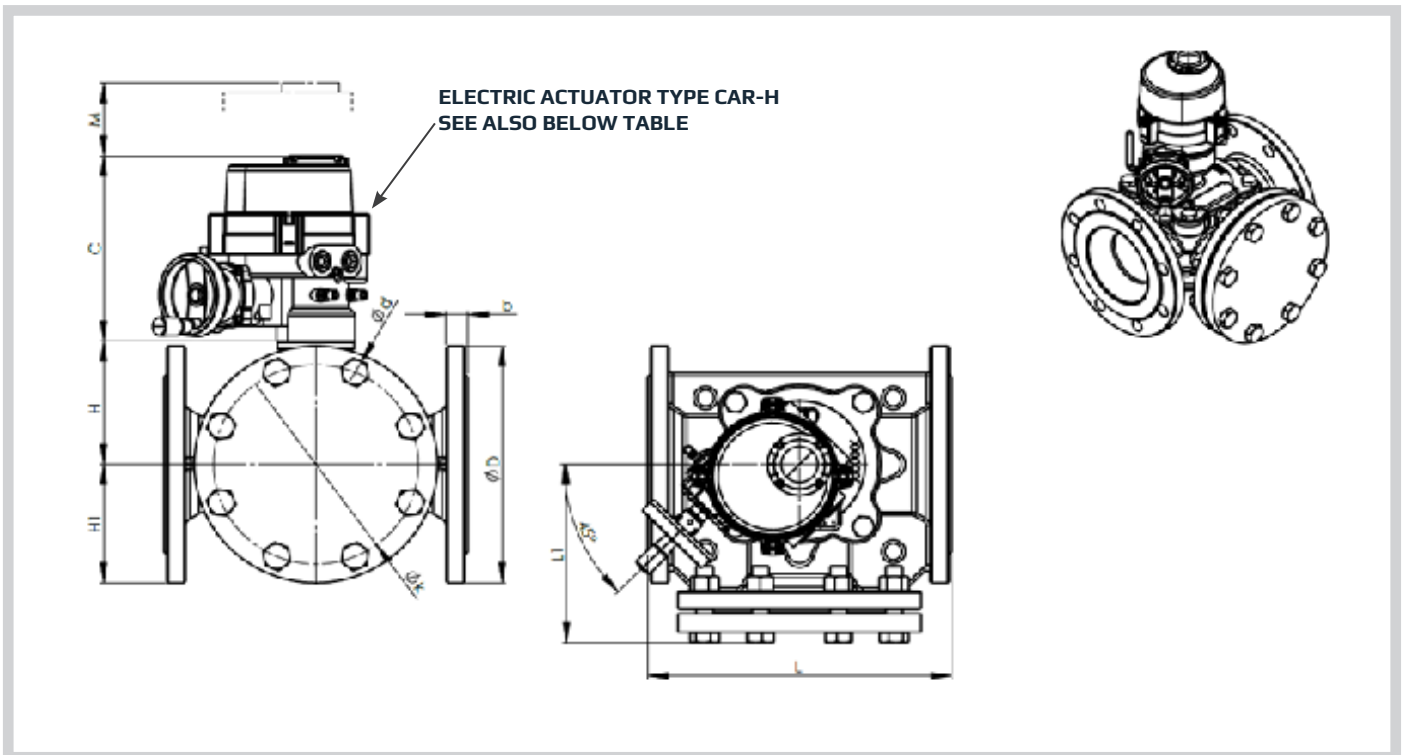

SPECIFICATIONS - TABLE 1 (read this together with table on page 4)

Type	L (mm)	L1 (mm)	H (mm)	H1 (mm)	b (mm)	C1 (mm)	M (mm)	Electric Actuator Type CAR-H
100 G2FMT-ULL (*HF)	296	180	140	ØD/2	24	223	110	CAR-H 006/010
125 G2FMT-ULL	330	199	140	ØD/2	24	223	110	CAR-H 006/010
125 G2FMT-ULL (JIS5K)	320	194	140	ØD/2	19	223	110	CAR-H 006/010
150 G2FMT-ULL	356	214,5	149	ØD/2	25,4	223	110	CAR-H 006/010
200 G2FMT-ULL	410	243,5	182	ØD/2	28,4	261	150	CAR-H 016
200 G2FMT-ULL (**L)	484	280,5	182	ØD/2	28,4	261	150	CAR-H -016
250 G2FMT-ULL	480	280,5	202	ØD/2	31	261	150	CAR-H -016
300 G2FMT-ULL (**RF)	580	330,5	202	ØD/2	32	261	150	CAR-H 016
300 G2FMT-ULL	560	320,5	237	ØD/2	32	315	180	CAR-H -035
350 G2FMT-ULL	660	370,5	256	ØD/2	36	315	180	CAR-H 050
400 G2FMT-ULL	720	403	278	ØD/2	38	315	180	CAR-H 050

* High Flow

** Long Version

*** Reduced Flow

ØD/2 - Depends on flange type (see also table 2)

SPECIFICATIONS
TABLE 2

Flange connections	EN 1092-2			ANSI Class 150			JIS B 2210 5K			JIS B 2210 10K		
	D (dia.) (mm)	k (dia.) (mm)	d mm dia. (num-)	D (dia.) (mm)	k (dia.) (mm)	d mm dia. (num-)	D (dia.) (mm)	k (dia.) (mm)	d mm dia. (num-)	D (dia.) (mm)	k (dia.) (mm)	d mm dia. (num-)
DN100	220	180	19x(8)	230	191	19x(8)	200	165	19x(8)	210	175	19x(8)
DN125	250	210	19x(8)	255	216	22x(8)	235	200	19x(8)	250	210	23x(8)
DN150	285	240	23x(8)	280	241	22x(8)	265	230	19x(8)	280	240	23x(8)
DN200	343	295	22x(8)	343	298	22x(8)	320	280	23x(8)	330	290	23x(12)
DN250	405	350	23x(12)	405	362	25x(12)	385	345	23x(12)	400	355	25x(12)
DN300	455	400	23x(12)	483	432	25x(12)	430	390	23x(12)	445	400	25x(16)
DN350	505	460	23x(16)	533	476	29x(12)	480	435	25x(12)	490	445	25x(16)
DN400	565	515	28x(16)	597	540	29x(16)	540	495	25x(16)	560	510	27x(16)

SPECIFICATIONS - TABLE 3

Type	Flange connection	Kv5 m ³ /h	Torque Nm	Weight kg
DN100 (*HF)	100	259	40	32
DN125	125	259	40	43
DN125 (JIS5K)	125	259	40	43
DN150	150	430	90	53
DN200 (**L)	200	770	120	85
DN200	200	770	120	85
DN250	250	1.230	150	122
DN300 (**RF)	300	1.190	150	174
DN300	300	2.090	320	162
DN350	350	2.950	418	215 (estimated)
DN400	400	3.760	530	269 (estimated)

*Torque calculated at max Δ P for: DN100 - 300 - 5 Bar

* High Flow

** Long Version

*** Reduced Flow

2-way Control Valve type G2FR

Nodular cast iron, PN 16, DN 100 – 150 mm, Reverse acting

0-2.5.07-E

Page 1 of 2



TECHNICAL DATA

Materials:

- Valve body	Nodular cast iron EN-GJS-400-15
- Trim	Stainless steel
- Bolts, nuts	24 CrMo 4/A4
- Gasket	Stainless steel foil - Copper

Nominal pressure	PN 16
Seating	Double seated
Flow characteristic	Almost quadratic
Function	Opens by pressing the spindle
Leakage rate	$\leq 0.5\%$ of Kvs
Regulating capability	Kvs/Kvr > 25

Flanges	EN 1092-2 PN 16
Counter flanges	DIN 2633

Reverse acting (normally closed)
For cooling water and lubrications

APPLICATIONS

Valves type G2FR are mainly intended for control of cooling systems. The valves are used in conjunction with temperature- or pressure differential regulators. As the reverse acting valves are held in closed position by means of a built-in spring, the max. differential pressure, Δp_L , against which a valve can close depends on the spring and when opening the valve, the actuator has to overcome the spring force. On the next page please find the max. allowable values of Δp_L as well as the max. allowable inlet pressures for opening the valves, p_{1max} for various actuator forces.

DESIGN

The valve components; spindle, seats and cone are made of stainless steel. The valve body is made of nodular cast iron EN-GJS-400-15 with flanges drilled according to EN 1092-2. The connection thread for the actuator is G1B ISO 228. The valves are double-seated and designed for tight closure. The leakage rate is less than 0.5% of the full flow (according to VDI/VDE 2174).

FUNCTION

REVERSE ACTING

Without an actuator being connected, the valve is held in closed position by means of a spring. With pressure on the spindle the valve opens. In connection with our actuators, the valves act as "cooling" valves, i.e. they open at rising temperatures. The linear characteristic will not cease until the flow has dropped below 4% of the full flow.

FEATURES

- Simple design secures reliable controls
- Location of the pack box in the actuator makes the valve service friendly
- Reliable and secure due to internal parts of stainless steel

PRESSURE/TEMPERATURE DIAGRAM

According to DIN 2401

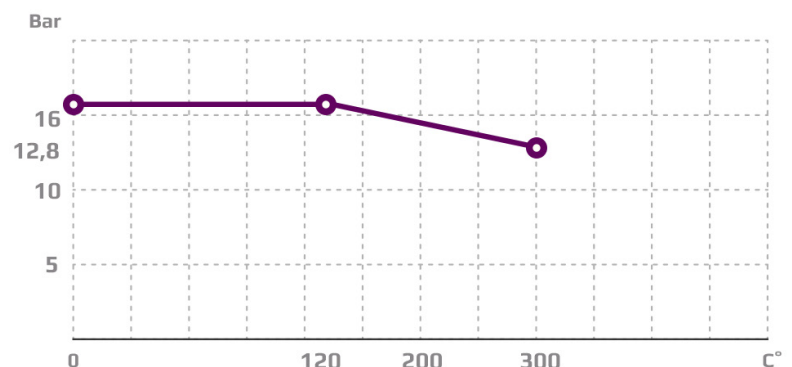

Subject to change without notice.

MOUNTING

The valve can be installed with vertical as well as horizontal spindles. For valve temperatures of max. 170 °C, the thermostat/ actuator can be fitted below or above the valve. For valve mounted with thermostats in media temperatures above 170 °C, a cooling unit has to be applied with connection downwards (please refer to data sheet for thermostat accessories). For electric actuators a high temperature adaptor must be used (please refer to data-sheets for the electric actuators).

DIMENSION SKETCH

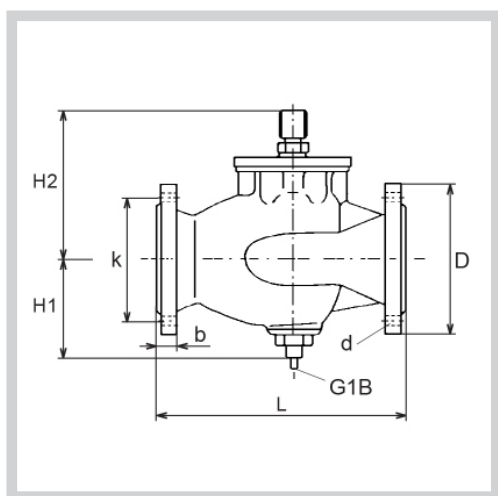

Type	L mm	H1 mm	H2 mm	D (dia.) mm	b mm	k (dia.) mm	d mm dia. (number)
100 G2FR	350	145	240	220	24	180	18x(8)
125 G2FR	400	160	260	250	26	210	18x(8)
150 G2FR	400	180	293	285	26	240	22x(8)

SPECIFICATIONS

Type	Flange connection Dn in mm	Opening mm	k_{vs} -value m ³ /h	Lifting height mm	Max. Δp_L bar	Actuat. force N	Weight kg
100 G2FR	100	100	125	20	12.1	800	39
125 G2FR	125	125	215	20	9	800	53
150 G2FR	150	150	310	20	7.5	800	73

3-way Control Valve type G3F

Nodular cast iron, PN 25, DN 20 – 65 mm, Flanged ends

0-2.5.08-I

Page 1 of 2

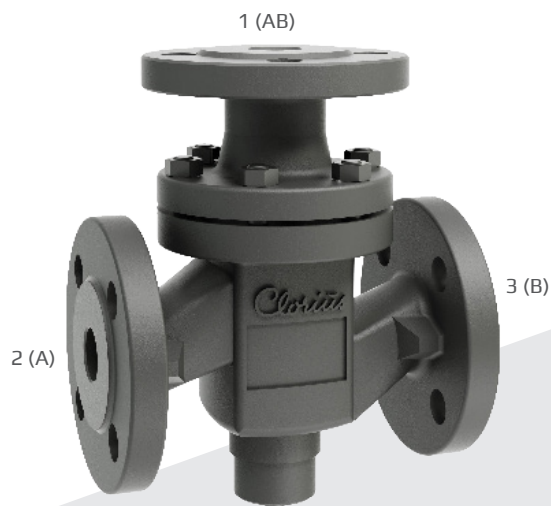

TECHNICAL DATA

Materials:

- Valve body	Nodular cast iron EN-GJS-400-15
- Components	Stainless steel
- Nuts, bolts	24 CrMo 5/A4
- Gasket	Graphite with stainless steel foil
- O-ring	70 FPM

Nominal pressure	PN 25
Seating	2 balanced single seats

Flow characteristic	Quadratic/linear
Leakage rate	$\leq 0.5\%$ of Kvs
Regulating capability	Kvs/Kvr > 25

Flanges - drilled according to Counter flanges	EN 1092-2 PN 25 DIN 2634
------------------------------------------------------	-----------------------------

Same Kvs-value as mixing and diverting valve

Subject to change without notice.

APPLICATIONS

Control valves type G3F are designed for hot water and hot oil systems and can be installed in pipe systems as mixing or diverting valves. The valves are used in conjunction with our temperature regulators for controlling industrial processes, district or central heating plants or marine installations.

DESIGN

The valve components - spindle, seats and cone - are made of stainless steel. The valve body is made of nodular cast iron EN-GJS-400-15 with flanges drilled according to EN 1092-2. The thread for the actuator connection is G1B ISO 228. The valves have two balanced single seats and are designed for tight closure. The leakage rate is less than 0.5% of the full flow (according to VDI/VDE 2174).

FUNCTION

Without an actuator being installed, connection A-AB is fully open and connection B-AB completely closed, by means of a spring. By increasing pressure on the spindle, the opening of the ports changes proportionally to the travel of the spindle, and when the spindle is pressed to the bottom, connection B-AB is fully open and connection A-AB completely closed.

The valve characteristics are as follows:

Port A-AB and AB-A: quadratic

Port B-AB and AB-B: almost linear

These characteristics ensure constant total flow under almost all pressure conditions and optimum circulation in the individual circuits.

FEATURES

- Can be used for both mixing and diverting
- Simple design secures reliable controls and reduces costly downtime
- Location of the pack box in the actuator makes the valve service friendly

PRESSURE/TEMPERATURE DIAGRAM

According to DIN 2401

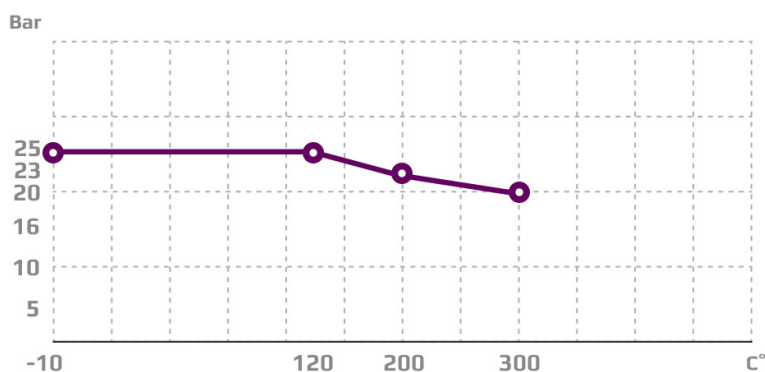

PORT NUMBERING

Valves type G3F are marked with the internationally recognized port designations: A, B, AB.

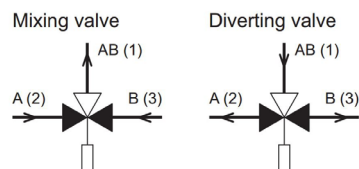

Port AB
Port A
Port B

common port always open
closes by activating the spindle
opens by activating the spindle



MOUNTING

The valve can be installed with vertical as well as horizontal spindles. For valve temperatures of max. 170 °C, the thermostat/ actuator can be fitted below or above the valve. For valve mounted with thermostats in media temperatures above 170 °C, a cooling unit has to be applied with connection downwards (please refer to data sheet for thermostat accessories). For electric actuators a high temperature adaptor must be used (please refer to data-sheets for the electric actuators).

DIMENSION SKETCH

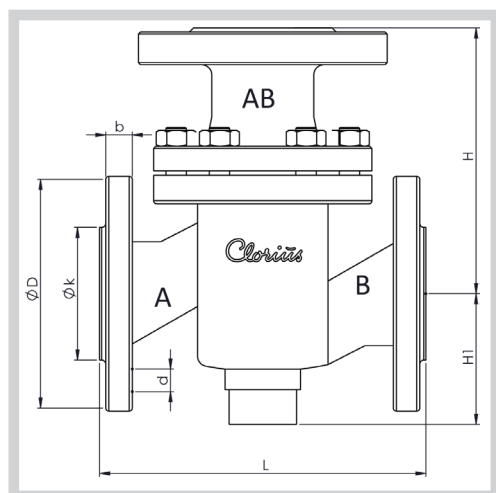

Type	L mm	H mm	H1 mm	D (dia.) mm	b mm	k (dia.) mm	d mm dia. (number)
20 G3F	150	115	63	105	16	75	14x(4)
25 G3F	160	130	70	115	16	85	14x(4)
32 G3F	180	150	75	140	18	100	18x(4)
40 G3F	200	160	85	150	18	110	18x(4)
50 G3F	230	190	95	165	20	125	18x(4)
65 G3F	290	220	110	185	20	145	18x(8)

SPECIFICATIONS

Type	Flange connection DN in mm	Opening mm	k_{vs} -value* m ³ /h	Lifting height mm	Weight kg
20 G3F	20	20	6.3	7.5	6
25 G3F	25	25	10	9	7
32 G3F	32	32	16	10	10
40 G3F	40	40	25	11	14
50 G3F	50	50	38	11.5	18
65 G3F	65	65	63	14.5	26

*Same k_{vs} -values for mixing and diverting valves

3-way Control Valve type G3F

Nodular cast iron, PN 16, DN 80 – 150 mm

0-2.5.09-E

Page 1 of 2



APPLICATIONS

Control valves type G3F are designed for regulating of water, lubricating oil and other liquid media and can be mounted in the pipe system as either mixing or diverting valves. However when mounting as a diverting valve the pressure drop is increased, compared with mounting as a mixing valve. See "Important note" under technical data. The valves are used in conjunction with our temperature regulators for controlling industrial processes, district and central heating plants and marine installations.

DESIGN

The valve components - seats and cone - are made of alubronze, the spindle is made of stainless steel. The valve body is made of nodular cast iron EN-GJS-400-15 with flanges drilled according to EN 1092-2 or ANSI B16.5 Class 150. The connection thread for the actuator is G1B ISO 228. The valves have two balanced single seats and are designed for tight closure. The leakage rate is less than 0.5% of the full flow (according to VDI/VDE 2174). [Tight between port 1(AB) og 3(B) is optional.]

FUNCTION

Without an actuator being installed, connection 2-1 is fully open and connection 3-1 completely closed, by means of a spring. By increasing pressure on the spindle, the opening of the ports changes proportionally to the travel of the spindle, and when the spindle is pressed to the bottom, connection 3-1 is fully open and connection 2-1 completely closed.

TECHNICAL DATA

Materials:

- Valve body	Nodular cast iron EN-GJS-400-15
- Seats and cone	Alu Bronze CuAL10Fe5Ni5
- Spindle	Stainless steel
- O-ring	90 NBR
- Gasket	Reinz-AFM34
Nominal pressure	PN 16
Seating	Two balanced single seats
Flow characteristic	Almost linear
Flanges drilled according to	EN 1092-2 PN 16 or ANSI B16.5 Class 150
Counter flanges	DIN 2633
Regulating capability	Kvs/Kvr > 25

For regulating of process- and central heating plants

Important note

In case the valves are applied as diverting valves, the pressure drop will increase by 35% and the k_{vs} -value will decrease by 14% as against mixing valves.

Subject to change without notice.

FEATURES

- Can be used for both mixing and diverting
- Simple design secures reliable controls and reduces costly downtime
- Location of the pack box in the actuator makes the valve service friendly

PRESSURE/TEMPERATURE DIAGRAM

According to DIN 2401

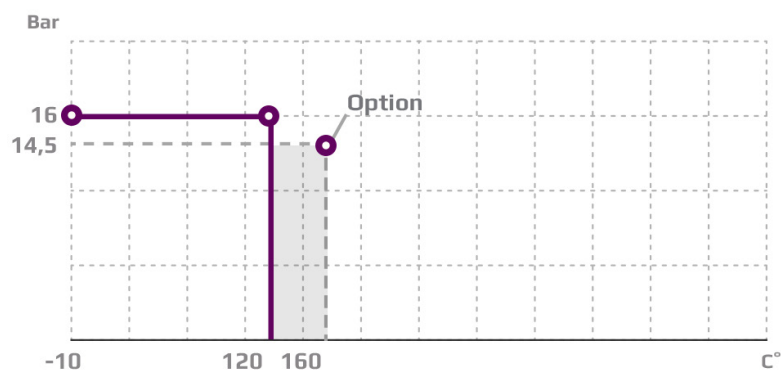

PORT NUMBERING

The ports of valves type G3F are marked with the figures 1, 2 and 3. The letters in parentheses refer to the corresponding internationally adapted designations.

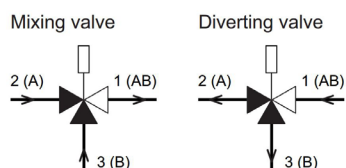

Port 1(AB)
Port 2(A)
Port 3(B)

common port always open
closes at load on spindle
opens at load on spindle



MOUNTING

The valves can be installed vertical as well as horizontal. The valves must be mounted in a way that the valve motor will be exposed to a minimum of moisture and unnecessary vibrations. Free height above / below the valve must be minimum 400 mm for mounting and operation of the AVM/AVF 234 motor, otherwise minimum 745 mm for pneumatic actuators.

DIMENSION SKETCH

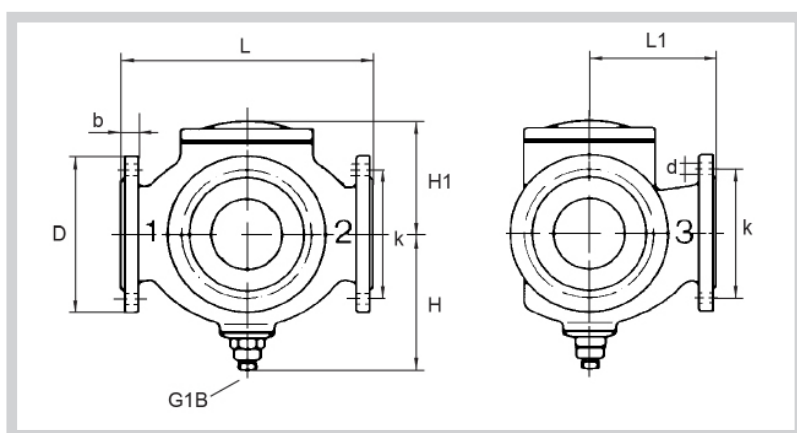

Type	L mm	L1 mm	H mm	H1 mm	D (dia.) mm	b mm	k (dia.) mm	d mm dia. (number)
80 G3F	310	155	180	127	200	19	160	19x(8)
100 G3F	350	175	195	141	220	19	180	19x(8)
125 G3F	400	240	245	171	250	19	210	19x(8)
150 G3F	480	270	280	189	285	24	240	23x(8)

SPECIFICATIONS

Type	Flange connection DN in mm	Opening mm	Mixing valve k_{vs} -value m^3/h	Divertng valve k_{vs} -value m^3/h	Lifting height mm	Weight kg
80 G3F	80	80	80	69	11	35
100 G3F	100	100	125	108	13	44
125 G3F	125	125	215	185	18	72
150 G3F	150	150	310	267	20	111

3-way Control Valve type G3F-I

(Ports A-AB interchanged) Nodular cast iron, PN 16, DN 80 – 150 mm

0-2.5.09.01-A

Page 1 of 2



APPLICATIONS

Control valves type G3F-I are designed for regulating of water, lubricating oil and other liquid media and can be mounted in the pipe system as either mixing or diverting valves. However when mounting as a diverting valve the pressure drop is increased, compared with mounting as a mixing valve. See "Important note" on page 2. The valves are used in conjunction with our temperature regulators for controlling industrial processes, district and central heating plants and marine installations.

DESIGN

The valve components - seats and cone - are made of alubronze, the spindle is made of stainless steel. The valve body is made of nodular cast iron EN-GJS-400-15 with flanges drilled according to EN 1092-2 or ANSI B16.5 Class 150. The connection thread for the actuator is G1B ISO 228. The valves have two balanced single seats and are designed for tight closure. The leakage rate is less than 0.5% of the full flow (according to VDI/VDE 2174). Tight between port 1(AB) og 3(B) is optional.

FUNCTION

Without an actuator being installed, connection 2-1 is fully open and connection 3-1 completely closed, by means of a spring. By increasing pressure on the spindle, the opening of the ports changes proportionally to the travel of the spindle, and when the spindle is pressed to the bottom, connection 3-1 is fully open and connection 2-1 completely closed.

TECHNICAL DATA

Materials:

- Valve body	Nodular cast iron EN-GJS-400-15
- Seats and cone	Alu Bronze CuAL10Fe5Ni5
- Spindle	Stainless steel
- O-ring	90 NBR
- Gasket	Reinz-AFM34
Nominal pressure	PN 16
Seating	Two balanced single seats Almost linear
Flow characteristic	
Flanges drilled according to	EN 1092-2 PN 16 or ANSI B16.5 Class 150
Counter flanges	DIN 2633
Regulating capability	Kvs/Kvr > 25

For regulating of process- and central heating plants

Important note

In case the valves are applied as diverting valves, the pressure drop will increase by 35% and the k_{vs} -value will decrease by 14% as against mixing valves.

FEATURES

- Can be used for both mixing and diverting
- Simple design secures reliable controls and reduces costly downtime
- Reliable and secure due to internal parts of stainless steel

PRESSURE/TEMPERATURE DIAGRAM

According to DIN 2401

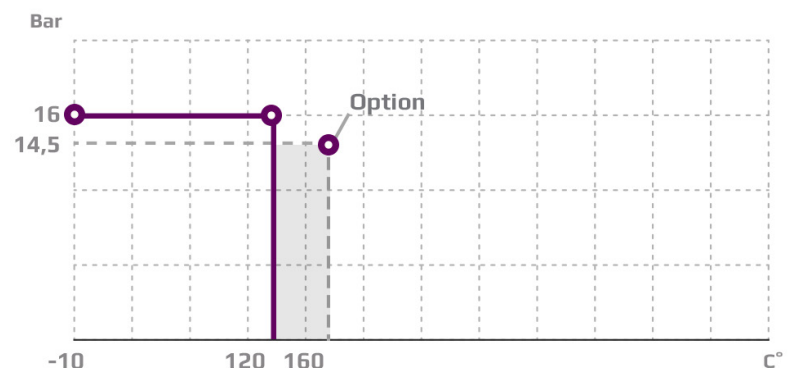

Subject to change without notice.

PORT NUMBERING

The ports of valves type G3F-I are marked with the figures 1, 2 and 3. The letters in parentheses refer to the corresponding internationally adapted designations.

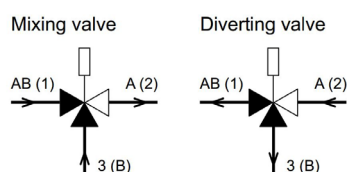

Port AB(1)
Port A(2)
Port 3(B)

common port always open
closes at load on spindle
opens at load on spindle



MOUNTING

The valves can be installed vertical as well as horizontal. The valves must be mounted in a way that the valve motor will be exposed to a minimum of moisture and unnecessary vibrations. Free height above / below the valve must be minimum 400 mm for mounting and operation of the AVM/AVF 234 motor, otherwise minimum 745 mm for pneumatic actuators.

DIMENSION SKETCH

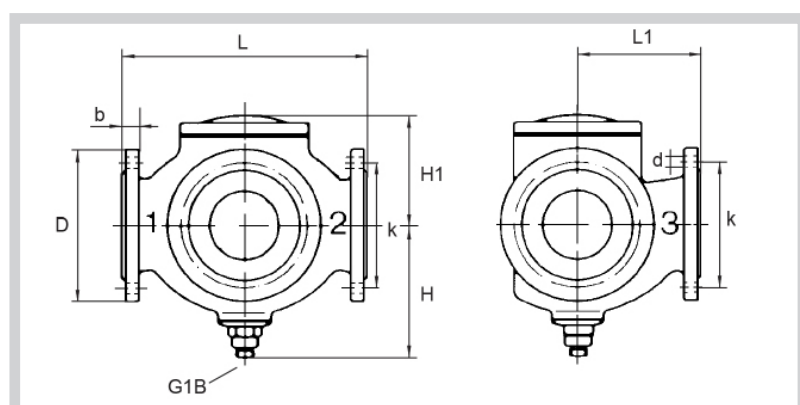

Type	L mm	L1 mm	H mm	H1 mm	D (dia.) mm	b mm	k (dia.) mm	d mm dia. (number)
80 G3F-I	310	155	180	127	200	19	160	19x(8)
100 M3F-I	350	175	195	141	220	19	180	19x(8)
125 M3F-I	400	240	245	171	250	19	210	19x(8)
150 M3F-I	480	270	280	189	285	24	240	23x(8)

SPECIFICATIONS

Type	Flange connection DN in mm	Opening mm	Mixing valve k_{vs} -value m^3/h	Diverting valve k_{vs} -value m^3/h	Lifting height mm	Weight kg
80 G3F-I	80	80	80	69	11	35
100 G3F-I	100	100	125	108	13	44
125 G3F-I	125	125	215	185	18	72
150 G3F-I	150	150	310	267	20	111

3-way Control Valve type Low Leakage

Nodular Cast Iron, PN16, DN80 – 300 mm / PN10, DN300/250 mm

0-2.5.14-A

Page 1 of 2



APPLICATIONS

Control valves type G3FA soft seated are designed for regulating of load dependant cylinder liner (LDCL), cooling water systems.

DESIGN

The valve components (seats and cone) are made of alubronzel, the spindle of alu. bronze. The valve body is made of nodular cast iron and the valve flanges are drilled according to EN 1092-2 (JIS B 2210 option). The valve has two balanced single seats and the port AB-B is designed 100 % tight.

FUNCTION

The valve cone is firmly connected with the actuator spindle. When the valve cone is in the one extreme position by draw on the spindle, connection A-AB is kept fully open and connection B-AB is fully closed. In the other extreme position connection A-AB is fully closed and connection B-AB is fully open. In the intermediate positions the opening degrees change proportionally.

TECHNICAL DATA

Materials:	
- Valve body	Nodular cast iron EN-GJS-400-15
- Seats and cone	Alu Bronze CuAL10Fe5Ni5
- Spindle	Stainless steel (W.no 1.4436)
- O-ring	A75H- Gasket Reinz-AFM34
Nominal pressure	
- DN 80-200	PN 16 (max.150°C)
- DN 300/250-300	PN 10 (max.150°C)
- DN 80-300	JIS 10K (option)
Seats	2 balanced single seats
Flow characteristic	Almost linear
Leakage Port AB-B	0.0%
Flanges	According to EN 1092-2, PN 16 & PN 10
- Option:	According to JIS B 2210 10K
Regulating capability	Kvs/Kvr > 25

Note!

Valve DN 200/175 has outer measures and flanges drilled as valve DN 200. Valve DN 300/250 has outer measures and flanges drilled as valve DN 300

Counter flanges (suggested for EN 1092-2)

- DN 80-200:	DIN 2633 – PN 16
- DN 300/250-300:	DIN 2632 – PN 10

Soft seat with O-ring
Leakage class IV

Subject to change without notice.

FEATURES

- Soft-seat makes the valve 99.99% tight between port AB-B for energy savings
- Can be used for both mixing and diverting
- Simple design secures reliable controls and reduces costly downtime

PRESSURE/TEMPERATURE DIAGRAM

According to DIN 2401

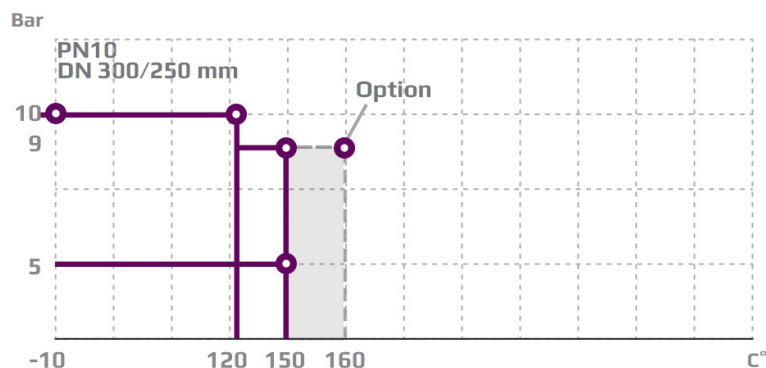
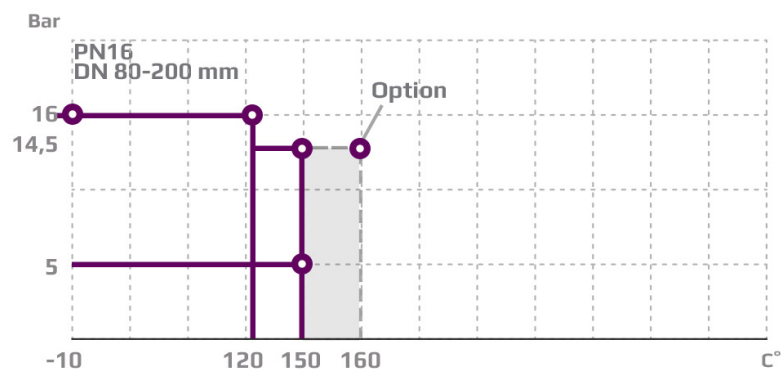

MOUNTING

The valves can be installed vertical as well as horizontal. The valves must be mounted in a way that the valve motor will be exposed to a minimum of moisture and unnecessary vibrations. Free height above / below the valve must be minimum 400 mm for mounting and operation of the AVM/AVF 234 motor, otherwise minimum 745mm for pneumatic actuators.

PORT NUMBERING

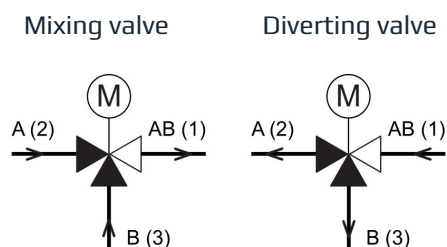

Port AB (1) common port always open
 Port A (2) closes at load on spindle
 Port B (3) opens at load on spindle

DIMENSION SKETCH

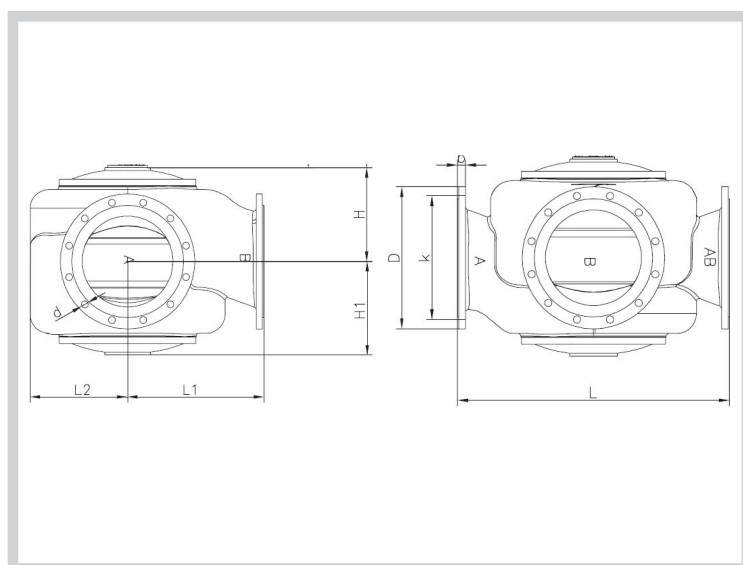

SPECIFICATIONS

DN	Flange connection DN in mm	Opening (mm)	k_{vs} -value m^3/h	Lifting height (mm)	Weight (kg)
80	80	80	80	11	35
100	100	100	125	13	44
125	125	125	215	18	72
150	150	150	310	22	111
200/175	200	200	425	23	165
200	200	200	555	29	160
300/250	300	300	865	31	306
300	300	300	1250	45	306

The stated kvs values apply for mixing valves. Diverting valves: 0.86 x (kvs -values for mixing valves)

DN	L (mm)	L1 (mm)	L2 (mm)	H (mm)	H1 (mm)	b (mm)	EN 1092-2			JIS B 2210 10K		
							D (dia.) (mm)	k (dia.) (mm)	d mm dia.	D (dia.) (mm)	k (dia.) (mm)	d mm dia.
80	310	155	102	117	127	19	200	160	19x(8)	185	150	19x(8)
100	350	175	112	132	141	19	220	180	19x(8)	210	175	19x(8)
125	400	240	138	181	171	19	250	210	19x(8)	250	210	23x(8)
150	480	270	165	216	189	24	285	240	23x(8)	280	240	23x(8)
200/175	600	325	230	238	238	20	340	295	23x(12)	330	290	23x(12)
200	600	325	230	238	238	20	340	295	23x(12)	330	290	23x(12)
300/250	850	450	325	305	305	25	445	400	23x(12)	445	400	25x(16)
300	850	450	325	305	305	25	445	400	23x(12)	445	400	25x(16)

3-way Control Valve type Low Leakage (INVERTED)

Nodular Cast Iron, PN16, DN 80 – 300 mm / PN10, DN300/250 mm

0-2.5.14.01-A

Page 1 of 2



TECHNICAL DATA

Materials:	
- Valve body	Nodular cast iron EN-GJS-400-15
- Seats and cone	Alu Bronze CuAL10Fe5Ni5
- Spindle	Stainless steel (W.no 1.4436)
- O-ring	A75H- Gasket Reinz-AFM34
Nominal pressure	
- DN 80-200	PN 16 (max.150°C)
- DN 300/250-300	PN 10 (max.150°C)
- DN 80-300	JIS 10K (option)
Seats	2 balanced single seats
Flow characteristic	Almost linear
Leakage Port AB-B	0.0%
Flanges	According to EN 1092-2, PN 16 & PN 10
- Option:	According to JIS B 2210 10K
Regulating capability	Kvs/Kvr > 25

Note!

Valve DN 200/175 has outer measures and flanges drilled as valve DN 200. Valve DN 300/250 has outer measures and flanges drilled as valve DN 300

Counter flanges (suggested for EN 1092-2)

- DN 80-200:	DIN 2633 – PN 16
- DN 300/250-300:	DIN 2632 – PN 10

Soft seat with O-ring
Leakage class IV

Subject to change without notice.

APPLICATIONS

Control valves type Low Leakage are designed for regulating of load dependant cylinder liner (LDCL), cooling water systems. The valve is designed with inverted ports for application with common port on the left side.

DESIGN

The valve components (seats and cone) are made of alubronzel, the spindle of stainless steel. The valve body is made of nodular cast iron and the valve flanges are drilled according to EN 1092-2 (JIS B 2210 option). The valve has two balanced single seats and the port AB-B is designed 100 % tight.

FUNCTION

The valve cone is firmly connected with the actuator spindle. When the valve cone is in the one extreme position by draw on the spindle, connection A-AB is kept fully open and connection B-AB is fully closed.

In the other extreme position connection A-AB is fully closed and connection B-AB is fully open. In the intermediate positions the opening degrees change proportionally.

FEATURES

- **Soft-seat makes the valve 99.99% tight between port AB-B for energy savings**
- **Can be used for both mixing and diverting**
- **Simple design secures reliable controls and reduces costly downtime**
- **Common port AB on the left side**

PRESSURE/TEMPERATURE DIAGRAM

According to DIN 2401

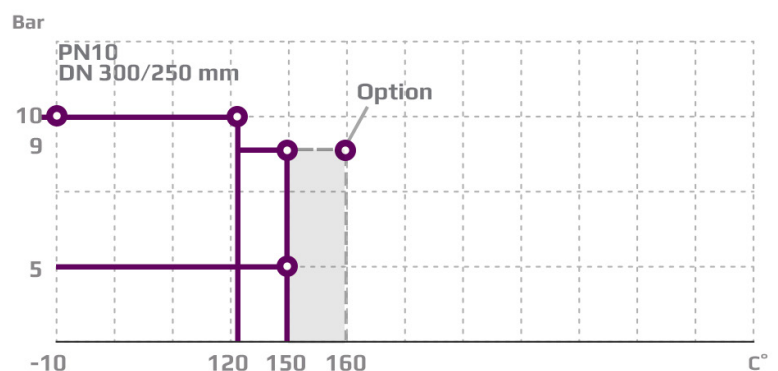
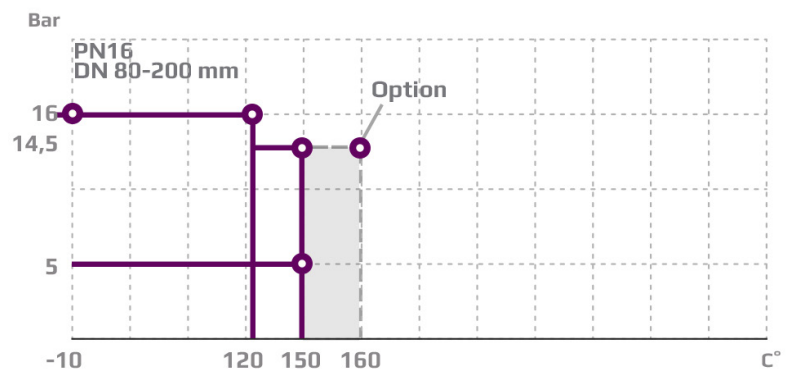

MOUNTING

The valves can be installed vertical as well as horizontal. The valves must be mounted in a way that the valve motor will be exposed to a minimum of moisture and unnecessary vibrations. Free height above / below the valve must be minimum 400 mm for mounting and operation of the AVM/AVF 234 motor, otherwise minimum 745 mm for pneumatic actuators.

PORT NUMBERING

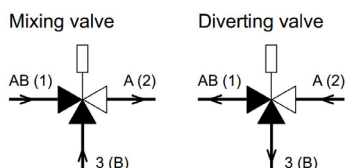

Port AB(1)
Port A(2)
Port 3(B)

common port always open
closes at load on spindle
opens at load on spindle

DIMENSION SKETCH

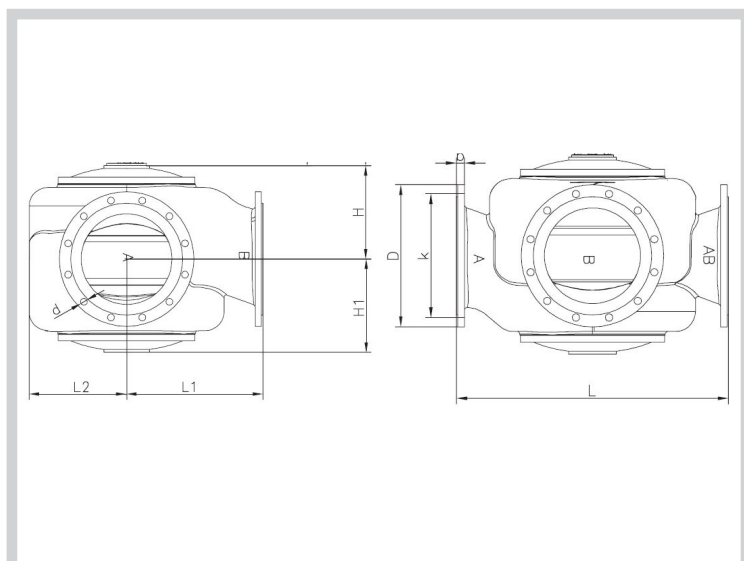

SPECIFICATIONS

DN	Flange connection DN in mm	Opening (mm)	k_{vs} -value m^3/h	Lifting height (mm)	Weight (kg)
80	80	80	80	11	35
100	100	100	125	13	44
125	125	125	215	18	72
150	150	150	310	22	111
200/175	200	200	425	23	165
200	200	200	555	29	160
300/250	300	300	865	31	306
300	300	300	1250	45	306

¹⁾The stated k_{vs} values apply for mixing valves. Diverting valves: $0.86 \times (k_{vs}$ -values for mixing valves)

DN	L (mm)	L1 (mm)	L2 (mm)	H (mm)	H1 (mm)	b (mm)	EN 1092-2			JIS B 2210 10K		
							D (dia.) (mm)	k (dia.) (mm)	d mm dia. (number)	D (dia.) (mm)	k (dia.) (mm)	d mm dia. (number)
80	310	155	102	117	127	19	200	160	19x(8)	185	150	19x(8)
100	350	175	112	132	141	19	220	180	19x(8)	210	175	19x(8)
125	400	240	138	181	171	19	250	210	19x(8)	250	210	23x(8)
150	480	270	165	216	189	24	285	240	23x(8)	280	240	23x(8)
200/175	600	325	230	238	238	20	340	295	23x(12)	330	290	23x(12)
200	600	325	230	238	238	20	340	295	23x(12)	330	290	23x(12)
300/250	850	450	325	305	305	25	445	400	23x(12)	445	400	25x(16)
300	850	450	325	305	305	25	445	400	23x(12)	445	400	25x(16)

3-way Control Valve type G3FA

Nodular cast iron, PN16, DN 80 – 300 mm / PN10, DN300/250 mm

0-2.5.16-A

Page 1 of 2



APPLICATIONS

Control valves type G3FA are designed for regulating of fresh water, lubricating oil and other liquid media. The valves are designed for use in conjunction with large industrial processes, district heating and marine installations, e.g. cooling of main and auxiliary engines. Is used in conjunction with Clorius valve motor type AVM/AVF 234 or Clorius pneumatic actuators.

DESIGN

The valve components (seats and cone) are made of alubronze, the spindle of stainless steel. The valve body is made of nodular cast iron and the valve flanges are drilled according to EN 1092-2 (JIS B 2210 option). Tight between port 1(AB) og 3(B) is optional.

FUNCTION

The valve cone is firmly connected with the motor spindle. When the valve cone is in the one extreme position by draw on the spindle, connection A-AB is kept fully open and connection B-AB is fully closed. In the other extreme position connection A-AB is fully closed and connection B-AB is fully open. In the intermediate positions the opening degrees change proportionally.

TECHNICAL DATA

Materials:	
- Valve body	Nodular cast iron EN-GJS-400-15
- Seats and cone	Alu Bronze CuAL10Fe5Ni5
- Spindle	Stainless steel (W.no 1.4436)
- O-ring	A75H
- Gasket	Reinz-AFM34
Nominal pressure	
- 80-200 G3FA:	PN 16 (max.120/160°C)
- 300/250-300 G3FA:	PN 10 (max 120/160°C)
- 80-300 G3FA:	JIS 10K (option)
Seats	2 balanced single seats
Flow characteristic	Almost linear
Leakage rate	≤ 0.5%
Regulating capability	Kvs/Kvr > 25
Flanges	According to EN 1092-2, PN 16 & PN 10
- Option:	According to JIS B 2210 10K

Note !

Valve type 200/175 G3FA has outer measures and flanges drilled as valve type 200 G3FA. Valve type 300/250 G3FA has outer measures and flanges drilled as valve type 300 G3FA.

Counter flanges (suggested for EN 1092-2)

- 80-200 G3FA:	DIN 2633 – PN 16
- 300/250-300 G3FA:	DIN 2632 – PN 10

For cooling and heating purposes

Important note

In case the valves are applied as diverting valves, the pressure drop will increase by 35% and the kvs-value will decrease by 14% as against mixing valves.

Subject to change without notice.

FEATURES

- Can be used for both mixing and diverting
- Simple design secures reliable controls and reduces costly downtime
- Location of the pack box in the actuator makes the valve service friendly

PRESSURE/TEMPERATURE DIAGRAM

According to DIN 2401

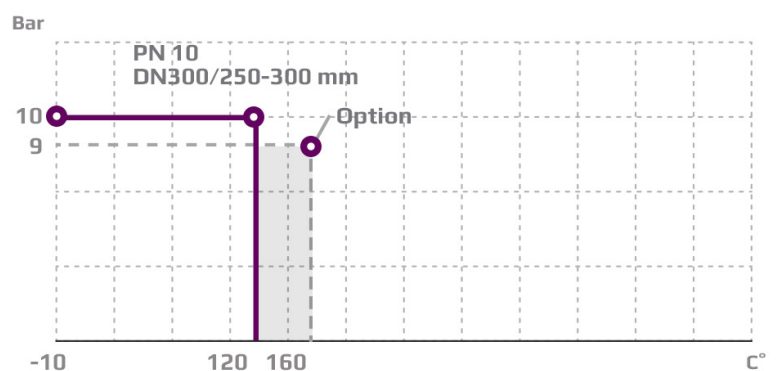
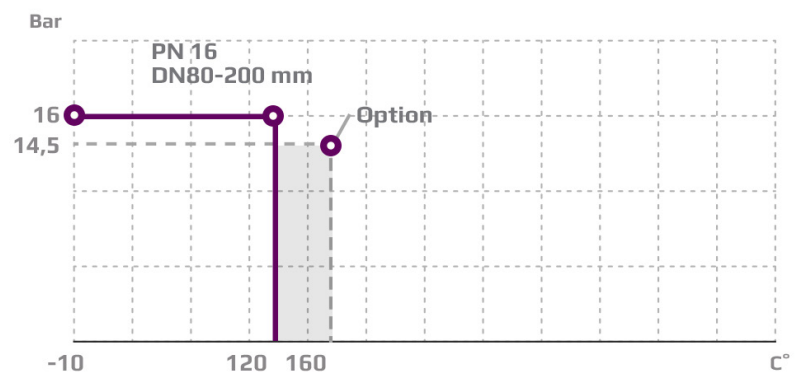

PORT NUMBERING

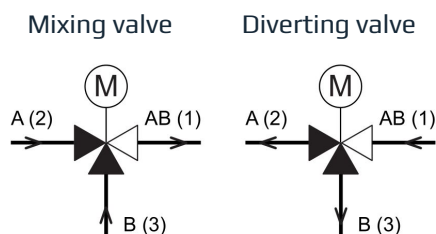

Port AB (1)
Port A (2)
Port B (3)

common port always open
closes at load on spindle
opens at load on spindle

1

MOUNTING

The valves can be installed vertical as well as horizontal. The valves must be mounted in a way that the valve motor will be exposed to a minimum of moisture and unnecessary vibrations. Free height above / below the valve must be minimum 400 mm for mounting and operation of the AVM/AVF 234 motor, otherwise minimum 745 mm for pneumatic actuators.

DIMENSION SKETCH

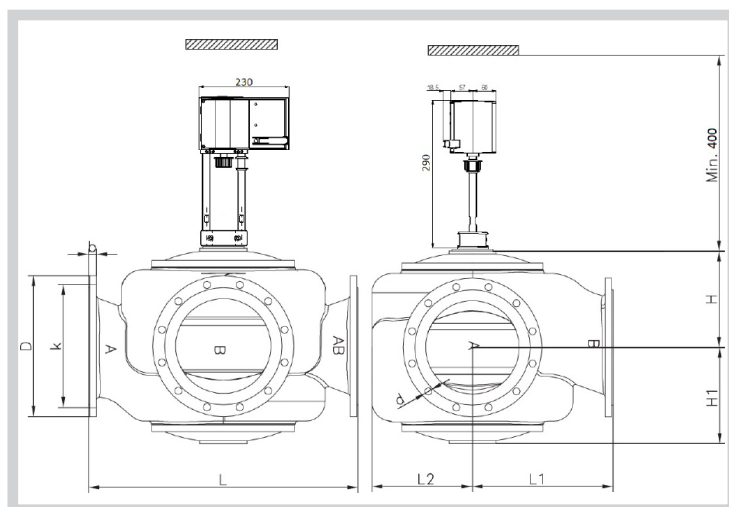

SPECIFICATIONS

Type	Flange connection DN in mm	Opening mm	k_{vs} -value ¹⁾ m ³ /h	Lifting height mm	Weight kg
80 G3FA	80	80	80	11	35
100 G3FA	100	100	125	13	44
125 G3FA	125	125	215	18	72
150 G3FA	150	150	310	20	111
200/175	200	200	425	22	165
200 G3FA	200	200	555	28	160
300/250	300	300	865	28	306
300 G3FA	300	300	1250	45	290

1) The stated kvs values apply for mixing valves. Diverting valves: 0.86 x (kvs-values for mixing valves).

Type	L mm	L1 mm	L2 mm	H mm	H1 mm	b mm	EN 1092-2			JIS B 2210 10K		
							D (dia.) mm	k (dia.) mm	d mm dia. (number)	D (dia.) mm	k (dia.) mm	d mm dia. (number)
80 G3FA	310	155	102	117	127	19	200	160	19x(8)	185	150	19x(8)
100 G3FA	350	175	112	132	141	19	220	180	19x(8)	210	175	19x(8)
125 G3FA	400	240	138	181	171	19	250	210	19x(8)	250	210	23x(8)
150 G3FA	480	270	165	216	189	24	285	240	23x(8)	280	240	23x(8)
200/175 G3FA	600	325	230	238	238	20	340	295	23x(12)	330	290	23x(12)
200 G3FA	600	325	230	238	238	20	340	295	23x(12)	330	290	23x(12)
300/250 G3FA	850	450	325	305	305	25	445	400	23x(12)	445	400	25x(16)
300 G3FA	850	450	325	305	305	25	445	400	23x(12)	445	400	25x(16)

3-way Control Valve type G3FA-HT

Nodular cast iron, PN 16, DN 80 – 200 mm / PN 10, DN 300/250 – 300 mm

HIGH TEMPERATURE (TEFLON GRAPHITE SEALING)

0-2.5.17.01-B

APPLICATIONS

Control valves type G3FA-HT are designed for regulating of fresh water, lubricating oil and other liquid media. The valves are designed for use in conjunction with large industrial processes, district heating and marine installations, e.g. cooling of main and auxiliary engines. The valve is used in conjunction with Clorius valve motor type MT90 Marine.

DESIGN

The valve components (seats and cone) are made of alubronze, the spindle of stainless steel. The valve body is made of nodular cast iron and the valve flanges are drilled according to EN 1092-2.

FUNCTION

The valve cone is firmly connected with the motor spindle. When the valve cone is in the one extreme position by draw on the spindle, connection A-AB is kept fully open and connection B-AB is fully closed. In the other extreme position connection A-AB is fully closed and connection B-AB is fully open. In the intermediate positions the opening degrees change proportionally.



TECHNICAL DATA

Materials:

- Valve body	Nodular cast iron EN-GJS-400-15
- Seats and cone	Alu Bronze CuAL10Fe5Ni5
- Spindle	Stainless steel (W.no 1.4436)
- O-ring	A75H
- Gasket	Reinz-AFM34

Nominal pressure

- 80-200 G3FA-HT:	PN 16 (max.120/150°C)
- 300/250-300 G3FA-HT:	PN 10 (max.120/150°C)

Seats	2 balanced single seats
Flow characteristic	Almost linear
Leakage rate	≤ 0.5%
Regulating capability	Kvs/Kvr > 25

Flanges **According to EN 1092-2,**
PN 16 & PN 10

Note !

Valve type 200/175 G3FA has outer measures and flanges drilled as valve type 200 G3FA. Valve type 300/250 G3FA has outer measures and flanges drilled as valve type 300 G3FA.

Counter flanges (suggested for EN 1092-2)

- 80-200 G3FA-HT:	DIN 2633 – PN 16
- 300/250-300 G3FA-HT:	DIN 2632 – PN 10

For cooling and heating purposes

Subject to change without notice.

FEATURES

- Can be used for both mixing and diverting
- Simple design secures reliable controls and reduces costly downtime
- Location of the pack box in the actuator makes the valve service friendly

PRESSURE/TEMPERATURE DIAGRAM

According to DIN 2401

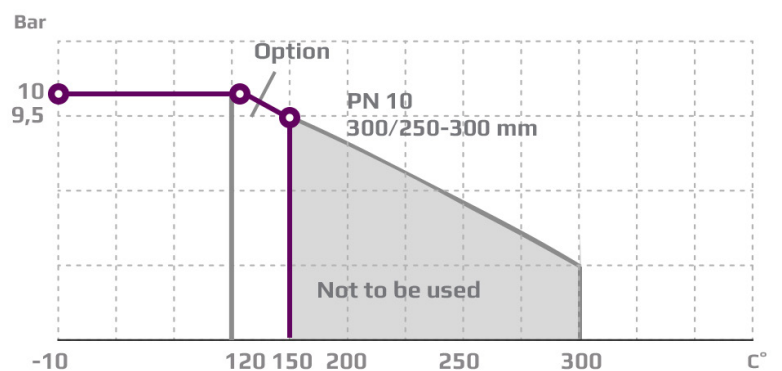
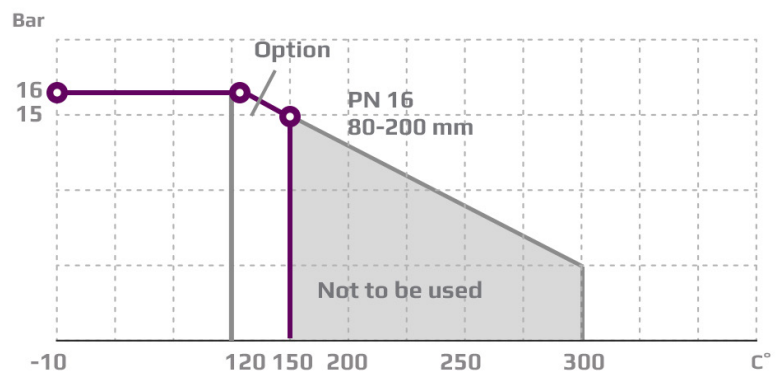

PORT NUMBERING

The ports of valves type G3FA-HT are marked with the letters AB, A and B. The letters in parentheses refer to the corresponding internationally adapted designations.

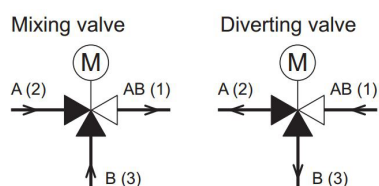

Port AB (1)
Port A (2)
Port B (3)

common port always open
closes at load on spindle
opens at load on spindle

MOUNTING

The valves can be installed vertical as well as horizontal. The valves must be mounted in a way that the valve motor will be exposed to a minimum of moisture and unnecessary vibrations. Free height above / below the valve must be minimum 400 mm for mounting and operation of the AVM/AVF 234 motor, otherwise minimum 745 mm for pneumatic actuators.

DIMENSION SKETCH

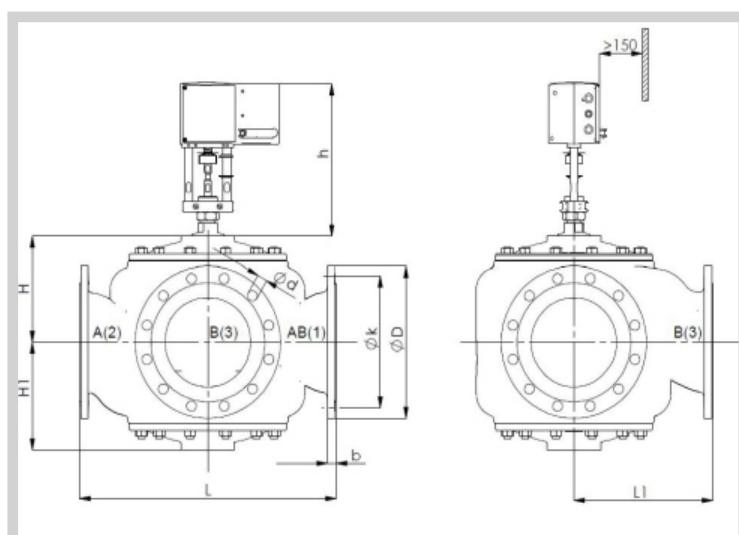

Type	L mm	L1 mm	H mm	H1 mm	b mm	D (dia.) mm	k (dia.) mm	d mm dia. (number)
80 G3FA-HT	310	155	117	127	19	200	160	19x(8)
100 G3FA-HT	350	175	132	141	19	220	180	19x(8)
125 G3FA-HT	400	240	181	171	19	250	210	19x(8)
150 G3FA-HT	480	270	216	189	24	285	240	23x(8)
200/175 G3FA-HT	600	325	238	238	20	340	295	23x(12)
200 G3FA-HT	600	325	238	238	20	340	295	23x(12)
300/250 G3FA-HT	850	450	305	305	25	445	400	23x(12)
300 G3FA-HT	850	450	305	305	25	445	400	23x(12)

SPECIFICATIONS

Type	Flange connection DN in mm	Opening mm	k_{vs} -value ¹⁾ m ³ /h	Lifting height mm	Weight kg
80 G3FA-HT	80	80	80	11	35
100 G3FA-HT	100	100	125	13	44
125 G3FA-HT	125	125	215	18	72
150 G3FA-HT	150	150	310	20	111
200/175 G3FA-HT	200	200	425	22	165
200 G3FA-HT	200	200	555	28	160
300/250 G3FA-HT	300	300	865	28	306
300 G3FA-HT	300	300	1250	45	290

¹⁾ The stated kvs values apply for mixing valves. Diverting valves: 0.86 x (kvs-values for mixing valves).

3-way Control Valve type G3FA-I

Nodular cast iron, DN 80 - 200 mm - PN 16, DN 300/250 and 300 mm - PN 10
(PORTS A-AB INTERCHANGED)
 0-2.5.18-A



APPLICATIONS

Control valves type G3FA-I are designed for regulating of fresh water, lubricating oil and other liquid media. The valves are designed for use in conjunction with large industrial processes, district heating and marine installations, e.g. cooling of main and auxiliary engines. Is used in conjunction with Clorius valve motor type AVM/F 234 or Clorius pneumatic actuators

DESIGN

The valve components (seats and cone) are made of alubronze, the spindle of stainless steel. The valve body is made of nodular cast iron and the valve flanges are drilled according to EN 1092-2 (JIS B 2210 option).

FUNCTION

The valve cone is firmly connected with the motor spindle. When the valve cone is in the one extreme position by draw on the spindle, connection B-AB is kept fully open and connection A-AB is fully closed. In the other extreme position connection B-AB is fully closed and connection A-AB is fully open. In the intermediate positions the opening degrees change proportionally.

TECHNICAL DATA

Materials:	
- Valve body	Nodular cast iron EN-GJS-400-15
- Seats and cone	Alu Bronze CuAL10Fe5Ni5
- Spindle	Stainless steel (W.no 1.4436)
- O-ring	A75H
- Gasket	Reinz-AFM34
Nominal pressure	
- 80-200 G3FA-I:	PN 16 (max.120/160°C)
- 300/250-300 G3FA-I:	PN 10 (max 120/160°C)
- 200/175-300 G3FA-I:	JIS 10K (option)
Seats	2 balanced single seats
Flow characteristic	Almost linear
Leakage rate	≤ 0.5%
Regulating capability	Kvs/Kvr > 25
Flanges	According to EN 1092-2, PN 16 & PN 10
- Option:	According to JIS B 2210 10K

Note !

Valve type 200/175 G3FA-I has outer measures and flanges drilled as valve type 200 G3FA-I.
 Valve type 300/250 G3FA-I has outer measures and flanges drilled as valve type 300 G3FA-I.

Counter flanges (suggested for EN 1092-2)

- 80-200 G3FA-I:	DIN 2633 – PN 16
- 300/250-300 G3FA-I	DIN 2632 – PN 10

For cooling and heating purposes

Subject to change without notice.

FEATURES

- Can be used for both mixing and diverting
- Simple design secures reliable controls and reduces costly downtime
- Location of the pack box in the actuator makes the valve service friendly

PRESSURE/TEMPERATURE DIAGRAM

According to DIN 2401

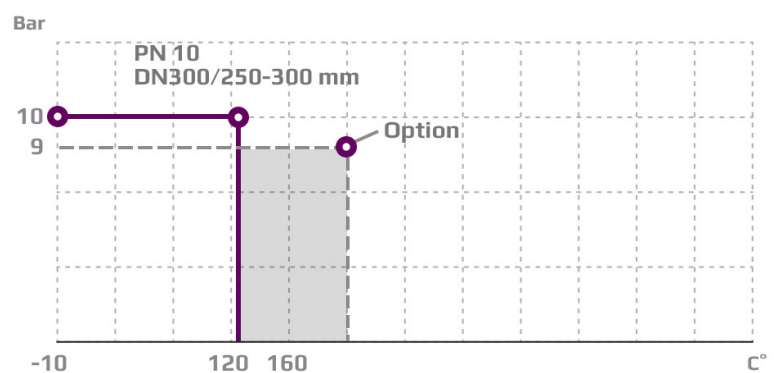
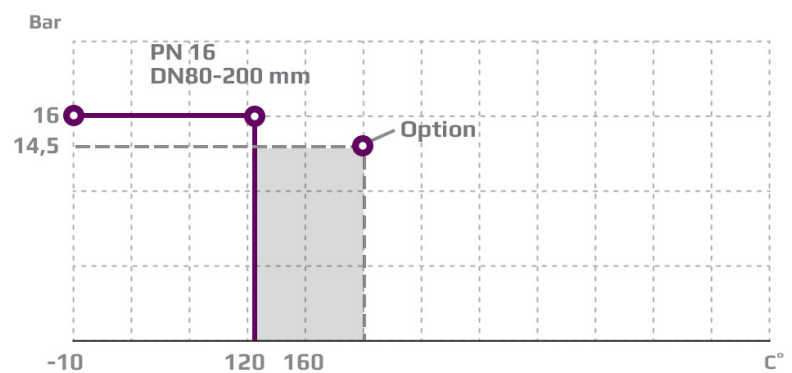

PORT NUMBERING

The ports of valves type G3FA-I are marked with the letters AB, A and B. The letters in parentheses refer to the corresponding internationally adapted designations.

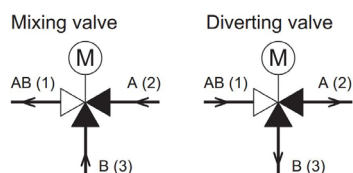

Port AB (1)
Port A (2)
Port B (3)

common port always open
opens at load on spindle
closes at load on spindle

MOUNTING

The valves can be installed vertical as well as horizontal. The valves must be mounted in a way that the valve motor will be exposed to a minimum of moisture and unnecessary vibrations. Free height above / below the valve must be minimum 400 mm for mounting and operation of the AVM/AVF 234 motor, otherwise minimum 745 mm for pneumatic actuators.

DIMENSION SKETCH

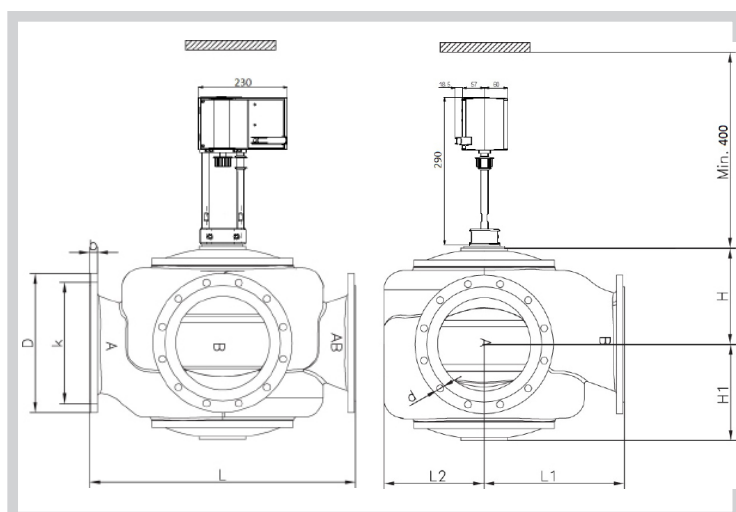

SPECIFICATIONS

Type	Flange connection DN in mm	Opening mm	k_{vs} -value ⁽¹⁾ m ³ /h	Lifting height mm	Weight kg
80 G3FA-I	80	80	80	11	35
100 G3FA-I	100	100	125	13	44
125 G3FA-I	125	125	215	18	72
150 G3FA-I	150	150	310	20	111
200/175 G3FA-I	200	200	425	22	165
200 G3FA-I	200	200	555	28	160
300/250 G3FA-I	300	300	865	28	306
300 G3FA-I	300	300	1250	45	290

1)The stated k_{vs} values apply for mixing valves. Diverting valves: 0.86 x (k_{vs} -values for mixing valves).

Type	L mm	L1 mm	L2 mm	H mm	H1 mm	b mm	EN 1092-2			JIS B 2210 10K		
							D (dia.) mm	k (dia.) mm	d mm dia.	D (dia.) mm	k (dia.) mm	d mm dia. (number)
80 G3FA-I	310	155	102	117	127	19	200	160	19x(8)	185	150	19x(8)
100 G3FA-I	350	175	112	132	141	19	220	180	19x(8)	210	175	19x(8)
125 G3FA-I	400	240	138	181	171	19	250	210	19x(8)	250	210	23x(8)
150 G3FA-I	480	270	165	216	189	24	285	240	23x(8)	280	240	23x(8)
200/175 G3FA-I	600	325	230	238	238	20	340	295	23x(12)	330	290	23x(12)
200 G3FA-I	600	325	230	238	238	20	340	295	23x(12)	330	290	23x(12)
300/250 G3FA-I	850	450	325	305	305	25	445	400	23x(12)	445	400	25x(16)
300 G3FA-I	850	450	325	305	305	25	445	400	23x(12)	445	400	25x(16)

3-way Control Valve type G3FA Soft Seat/Low Leakage

Nodular Cast Iron, PN16, DN 80 – 200 mm / PN10, DN300/250 - 300 mm

0-2.5.19-B

Page 1 of 2



APPLICATIONS

G3FA soft seat control valves are designed for regulating of low and high temperature cooling systems for marine engines.

DESIGN

The valve components (seats, cone and spindle) are made of aluminum bronze. The valve body is made of nodular cast iron and the valve flanges are drilled according to EN 1092-2 (JIS B 2210 option). The valve has two balanced single seats and the design of port AB-B is 100 % tight.

FUNCTION

The valve cone is firmly connected to the actuator spindle. When the valve cone is located in one extreme position by drawing on the spindle, port A-AB is kept fully open and port B-AB is fully closed. In the other extreme position port A-AB is fully closed and port B-AB is fully open. In the intermediate positions the opening degrees change proportionally.

TECHNICAL DATA

Materials:	
- Valve body	Nodular cast iron EN-GJS-400-15
- Color	RAL 7016 (anthracite grey)
- Seats and cone	Aluminum Bronze CuAL10Fe5Ni5
- Spindle	CuAL10Fe5Ni5 (W.no 1.4436)
- O-ring	A75H
- Gasket	Reinz-AFM34
Nominal pressure	
- 80-200 G3FA:	PN 16 (max.120/160°C)
- 300/250-300 G3FA:	PN 10 (max 120/160°C)
- 80-300 G3FA:	JIS 10K (option)
Seats	2 balanced single seats
Flow characteristic	Almost linear
Leakage rate	≤ 0.01%
Regulating capability	Kvs/Kvr > 25
Flanges	According to EN 1092-2, PN 16 & PN 10
- Option:	According to JIS B 2210 10K

Note !

Valve type 200/175 G3FA has outer measures and flanges drilled as for valve type 200 G3FA. Valve type 300/250 G3FA has outer measures and flanges drilled as valve type 300 G3FA.

Counter flanges (suggested for EN 1092-2)

- 80-200 G3FA:	DIN 2633 – PN 16
- 300/250-300 G3FA:	DIN 2632 – PN 10

For cooling and heating purposes

Important note

If the valves are applied as diverting valves, the pressure drop will increase by 35% and the Kvs-value will decrease by 14% compared with mixing valves.

Subject to change without notice.

FEATURES

- Soft-seat makes the valve 99.99% tight between port AB-B for energy savings
- Can be used for both mixing and diverting
- Simple design endures reliable control and reduces costly downtimes
- Designed for linear electric actuators

PRESSURE/TEMPERATURE DIAGRAM

According to DIN 2401

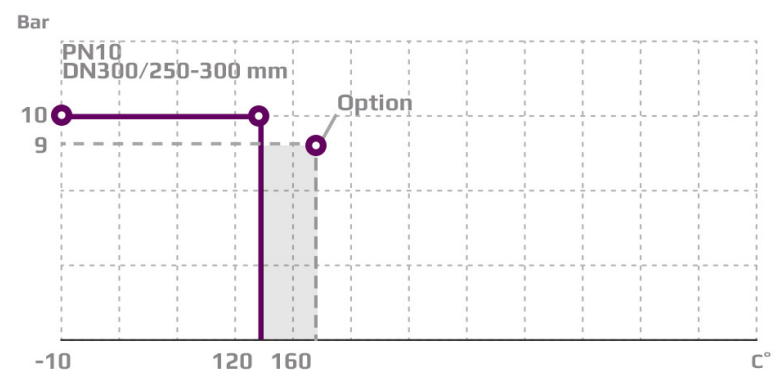
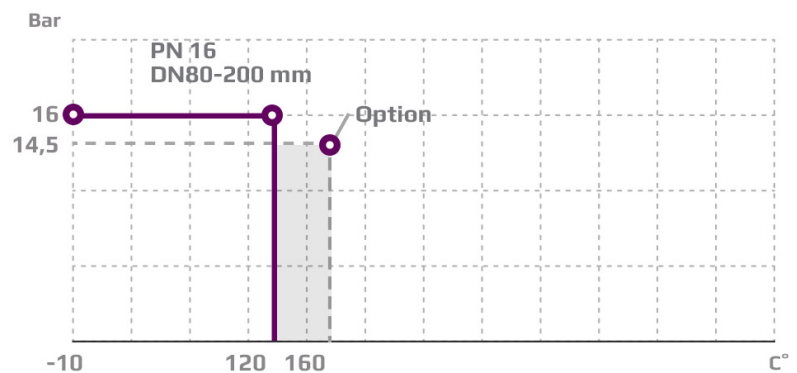

MOUNTING

The valves can be installed both vertically and horizontally. The valves must be mounted in such a way that the valve motor is exposed to minimal moisture and unnecessary vibrations. Free height above / below the valve must be a minimum 400 mm to mount and operate of the AVM/AVF 234 motor.

PORT NUMBERING

Mixing valve

Diverting valve

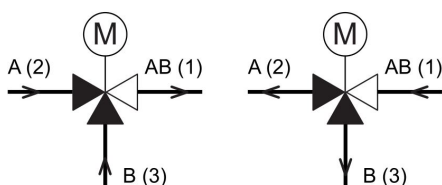

Port AB (1) common port always open
 Port A (2) closes for load on spindle
 Port B (3) opens for load on spindle

DIMENSION SKETCH

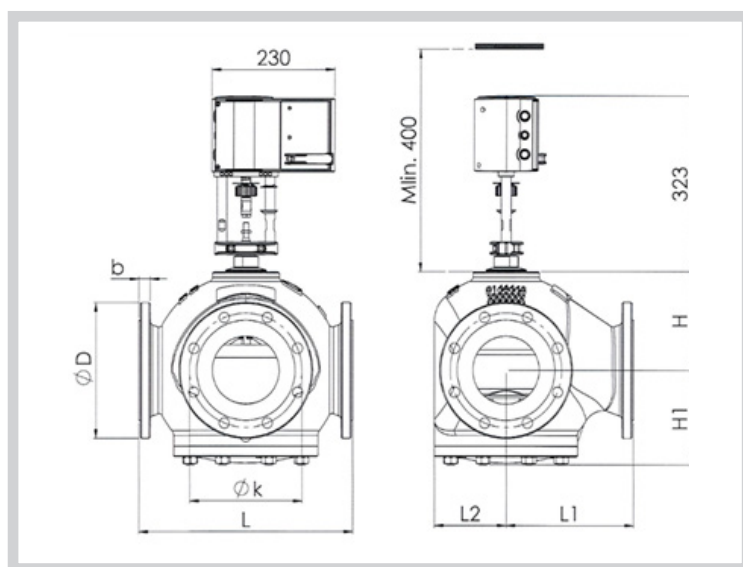

SPECIFICATIONS

Type	Flange connection DN in mm	Opening mm	k_{vs} -value ¹⁾ m ³ /h	Lifting height mm	Weight kg
80 G3FA	80	80	80	11	35
100 G3FA	100	100	125	13	44
125 G3FA	125	125	215	18	72
150 G3FA	150	150	310	20	111
200/175 G3FA	200	200	425	22	165
200 G3FA	200	200	555	28	160
300/250 G3FA	300	300	865	28	306
300 G3FA	300	300	1250	45	290

1) The stated k_{vs} values apply for mixing valves. Diverting valves: $0.86 \times (k_{vs}\text{-values for mixing valves})$.

Type	L mm	L1 mm	L2 mm	H mm	H1 mm	b mm	EN 1092-2			JIS B 2210 10K		
							D (dia.) mm	k (dia.) mm	d mm dia. (number)	D (dia.) mm	k (dia.) mm	d mm dia. (number)
80 G3FA	310	155	102	117	127	19	200	160	19x(8)	185	150	19x(8)
100 G3FA	350	175	112	132	141	19	220	180	19x(8)	210	175	19x(8)
125 G3FA	400	240	138	181	171	19	250	210	19x(8)	250	210	23x(8)
150 G3FA	480	270	165	216	189	24	285	240	23x(8)	280	240	23x(8)
200/175 G3FA	600	325	230	238	238	20	340	295	23x(12)	330	290	23x(12)
200 G3FA	600	325	230	238	238	20	340	295	23x(12)	330	290	23x(12)
300/250 G3FA	850	450	325	305	305	25	445	400	23x(12)	445	400	25x(16)
300 G3FA	850	450	325	305	305	25	445	400	23x(12)	445	400	25x(16)

3-way Control Valve type G3FM-TR (AB-Right)

Nodular cast iron, PN25, DN 65 – 125 mm / PN16, DN150 - 300 mm / PN10, DN 350 - 800 mm

0-2.6.02-x

Page 1 of 4



APPLICATIONS

Control valve type G3FM-TR is a three-way control valve with a slide for quarter turn operation designed for regulating of fresh water, lubricating oil and other liquid media. The valves are designed for use in conjunction with industrial processes, district heating and marine installations with large water or lubricating oil volumes:

- Engine Jacket Cooling Water System
- Lubricating Oil Cooling
- Central Cooling Water System, etc.

The valves are designed for use in conjunction with valve motor type CAR-H with handle for manual operation or for use in conjunction with a pneumatic actuator.

DESIGN

The valve body and the valve slide are made of nodular cast iron. The valve flanges are drilled according to EN 1092-2 (JIS B 2210 option).

FUNCTION

The slide is firmly connected with the motor spindle. When the slide is in the one outer position by turning the spindle, connection A-AB is fully open and connection B-AB is fully closed. In the other outer position connection A-AB is fully closed and connection B-AB is fully open. In the intermediate positions the opening degrees change proportionally. The valve has a small tolerance between body and slide. To minimize the leakage an O-ring is mounted in a groove on the slide.

TECHNICAL DATA

Materials:	
- Valve body, slide	Nodular cast iron EN-GJS-400-15
- O-ring	NBR 70A
- U-ring	PTFE
Flow characteristic	Almost linear
Leakage rate	Max. 0.5%
Regulating capability	Kvs/Kvr > 25

Flanges	EN 1092-2 PN 10/16/25
- Option	JIS B 2210 5K
Counter flanges (suggested for EN 1092-2)	
DIN 2632 – PN 10	
DIN 2633 – PN 16	
DIN 2634 – PN 25	

Max. pressure Δp_L, against which the valve can close:	
- DN 65 - 125	25 bar
- DN 150-300	16 bar
- DN 350-800	10 bar

Nominal pressure	
- DN 65-125 mm	PN 25 max. 100 °C (option 250°C)
- DN 150-300 mm	PN 16, max. 100°C (option 250°C)
- DN 350-800 mm	PN 10, max. 100°C (option 250°C)
- DN 150-800 mm	JIS 5K (option)

Slide in Nodular cast iron

Subject to change without notice.

FEATURE

- Simple design secures reliable controls and reduces costly downtime
- Low leakage rate secures energy savings
- Flexible choice of port placement

PRESSURE/TEMPERATURE DIAGRAM

According to DIN 2401

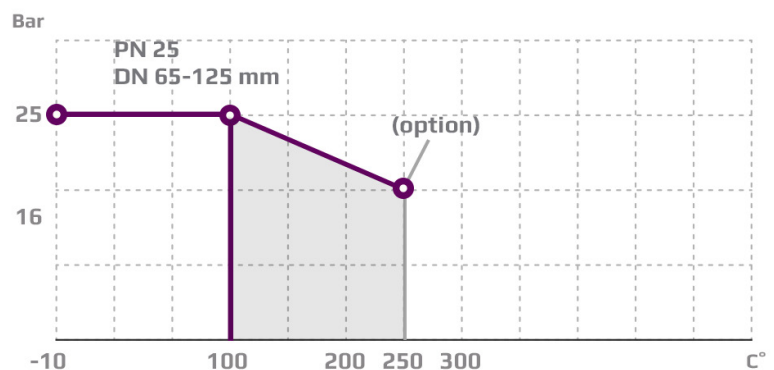

PRESSURE/TEMPERATURE DIAGRAM

According to DIN 2401

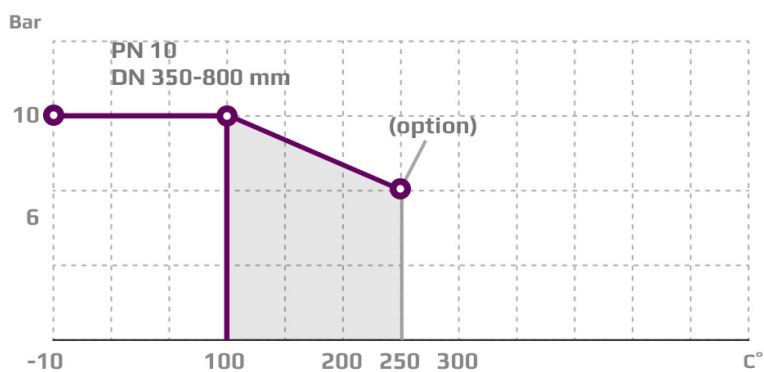
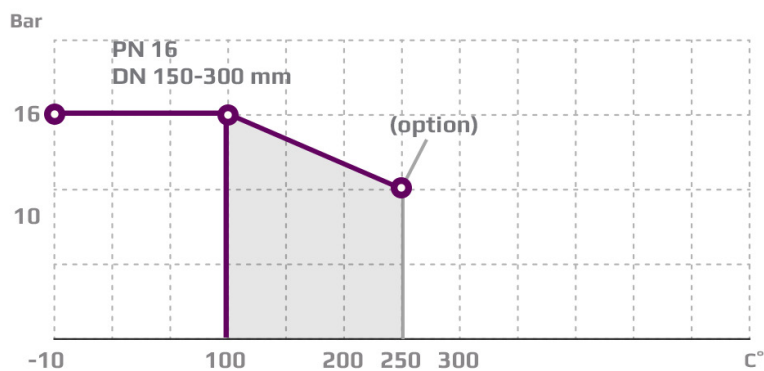

PORT NUMBERING

Mixing

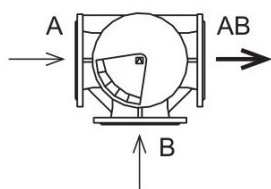

Diverting

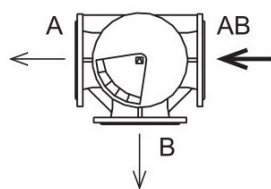

MOUNTING

The valve connections are marked A, B and AB. The slide is operating between A and B. Check slide position before installation in the pipe. The slide position is marked on the top of the shaft. The valves can be installed with vertical as well as horizontal spindles. The valves must be mounted in a way that the valve actuator will be exposed to a minimum of moisture and unnecessary vibrations.

Valves can also be supplied in AB-Left configuration (data sheet 2.6.03) and AB-Middle (data sheet 2.6.03.02).

3-way Control Valve type G3FM-TR (AB-Right)

Nodular cast iron, PN25, DN 65 – 125 mm / PN16, DN150 - 300 mm / PN10, DN 350 - 800 mm

0-2.6.02-X

Page 3 of 4

DIMENSION SKETCH

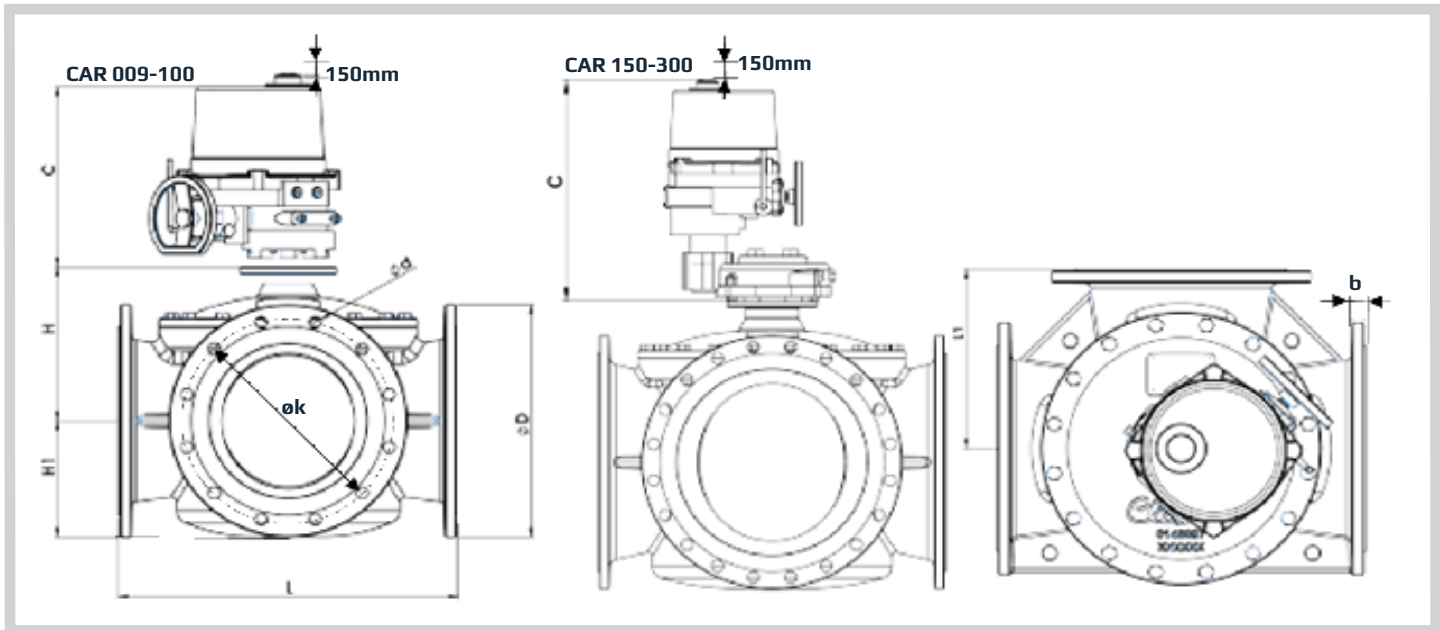

Type	EN 1092-2						ANSI Class 150			JIS B 2210 5K			JIS B 2210 10K					
	L (mm)	L1 (mm)	H (mm)	H1 (mm)	b (mm)	C (mm)	D (dia.) (mm)	k (dia.) (mm)	d mm dia. (number)	D (dia.) (mm)	k (dia.) (mm)	d mm dia. (number)	D (dia.) (mm)	k (dia.) (mm)	d mm dia. (number)	D (dia.) (mm)	k (dia.) (mm)	d mm dia. (number)
65 G3FM-TR	292	146	135	92	19	273	185	145	19x(8)	180	140	19x(4)	155	130	15x(4)	175	140	19x(4)
80 G3FM-TR	292	146	140	94	20	273	200	160	19x(8)	190	152	19x(4)	180	145	19x(4)	185	150	19x(8)
100 G3FM-TR	350	175	158	112	17	273	235	190	23x(8)	230	190.9	19x(8)	200	165	19x(8)	210	175	19x(8)
125 G3FM-TR	400	200	179	123	19	273	270	220	28x(8)	255	216	22x(8)	235	200	19x(8)	250	210	23x(8)
150 G3FM-TR	437	218.5	196	139	19	276	285	240	23x(8)	280	241	22x(8)	265	230	19x(8)	280	240	23x(8)
200 G3FM-TR	530	265	232	169	20	361	340	295	23x(12)	343	299	23x(8)	320	280	23x(8)	320	290	23x(12)
250 G3FM-TR	592	296	272	199	22	361	400	355	28x(12)	407	362	26x(12)	385	345	23x(12)	400	355	25x(12)
300 G3FM-TR	649	324.5	302	227	25	361	455	410	28x(12)	483	432	26x(12)	430	390	23x(12)	445	400	25x(16)
350 G3FM-TR	717	358.5	334.5	251.5	25	361	505	460	23x(16)	534	477	29x(12)	480	435	25x(12)	490	445	25x(16)
400 G3FM-TR	770	385	370	282	25	361	565	515	28x(16)	597	540	29x(16)	540	495	25x(16)	560	510	27x(16)
450 G3FM-TR	820	410	391	307	26	556	615	565	28x(20)	635	578	32x(16)	605	555	25x(16)	620	565	27x(20)
500 G3FM-TR	900	450	421	335	27	556	670	620	28x(20)	699	635	32x(20)	655	605	25x(20)	675	620	27x(20)
550 G3FM-TR	900	450	421	335	27	556	-	-	-	-	-	-	720	665	27x(20)	745	680	33x(20)
600 G3FM-TR	918	459	470	354	31	556	780	725	31x(20)	813	750	35x(20)	770	715	25x(20)	795	730	33x(24)
650 G3FM-TR	1050	525	534	426	37	556	-	-	-	-	-	-	825	770	27x(24)	845	780	33x(24)
800 G3FM-TR	1230	615	596	461	53	556	1085	990	34x(24) 50x(24) PN25	-	-	-	995	930	33x(24)	1020	950	33x(28)

SPECIFICATIONS

Type	Flange connection	k_{vs} -value ⁽¹⁾ Mixing valve	k_{vs} -value ⁽¹⁾ Diverting valve	Torque Nm	Weight kg
65 G3FM-TR	65	95	120	60	26
80 G3FM-TR	80	122	154	65	29
100 G3FM-TR	100	175	220	120	41
125 G3FM-TR	125	245	330	200	58
150 G3FM-TR	150	395	425	200	71
200 G3FM-TR	200	800	1100	330	114
250 G3FM-TR	250	1500	2100	525	159
300 G3FM-TR	300	2000	2650	730	207
350 G3FM-TR	350	2530	3380	980	278
400 G3FM-TR	400	3050	3950	1370	346
450 G3FM-TR	450	3680	4480	1550	433
500 G3FM-TR	500	4150	5250	1920	563
550 G3FM-TR	550	4150	5250	1920	575
600 G3FM-TR	600	4800	6050	2950	816
650 G3FM-TR	650	6700	7800	TBC	1050
800 G3FM-TR	800	6200	8000	4000	2100

¹⁾ k_{vs} -value for port A and B 50% open.

*Torque calculated at max inlet P for:
 DN 65 - 125 = 25 Bar
 DN 150-300 = 16 Bar
 DN 350-800 = 10 Bar



3-way Control Valve type G3FM-TL (AB-Left)

Nodular cast iron, PN25, DN 65 – 125 mm / PN16, DN150 - 300 mm / PN10, DN 350 - 800 mm

0-2.6.03-I

Page 1 of 4



TECHNICAL DATA

Materials:

- Valve body, slide	Nodular cast iron EN-GJS-400-15
- O-ring	NBR 70A
- U-ring	PTFE
Flow characteristic	Almost linear
Leakage rate	Max. 0.5%
Regulating capability	Kvs/Kvr > 25

Flanges	EN 1092-2 PN 10/16
- Option	JIS B 2210 5K

Counter flanges (suggested for EN 1092-2)

DIN 2632 – PN 10
DIN 2633 – PN 16

Max. pressure Δp_L , against which the valve can close:

- DN 65 - 125	25 bar
- DN 150-300	16 bar
- DN 350-800	10 bar

Nominal pressure

- DN 65-125 mm	PN 25 max. 100 °C (option 250°C)
- DN 150-300 mm	PN 16, max. 100°C (option 250°C)
- DN 350-800 mm	PN 10, max. 100°C (option 250°C)
- DN 150-800 mm	JIS 5K (option)

Slide in Nodular cast iron

Subject to change without notice.

APPLICATIONS

Control valve type G3FM-TL is a three-way control valve with a slide for quarter turn operation designed for regulating of fresh water, lubricating oil and other liquid media. The valves are designed for use in conjunction with industrial processes, district heating and marine installations with large water or lubricating oil volumes:

- Engine Jacket Cooling Water System
- Lubricating Oil Cooling
- Central Cooling Water System, etc.

The valves are designed for use in conjunction with valve motor type CAR-H with handle for manual operation or for use in conjunction with a pneumatic actuator.

DESIGN

The valve body and the valve slide are made of nodular cast iron. The valve flanges are drilled according to EN 1092-2 (JIS B 2210 option).

FUNCTION

The slide is firmly connected with the motor spindle. When the slide is in the one outer position by turning the spindle, connection A-AB is fully open and connection B-AB is fully closed. In the other outer position connection A-AB is fully closed and connection B-AB is fully open. In the intermediate positions the opening degrees change proportionally. The valve has a small tolerance between body and slide. To minimize the leakage an O-ring is mounted in a groove on the

FEATURE

- Simple design secures reliable controls and reduces costly downtime
- Low leakage rate secures energy savings
- Flexible choice of port placement

PRESSURE/TEMPERATURE DIAGRAM

According to DIN 2401

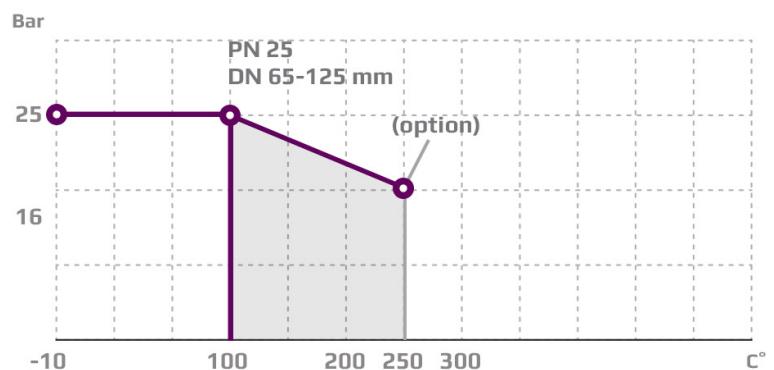

PRESSURE/TEMPERATURE DIAGRAM

According to DIN 2401

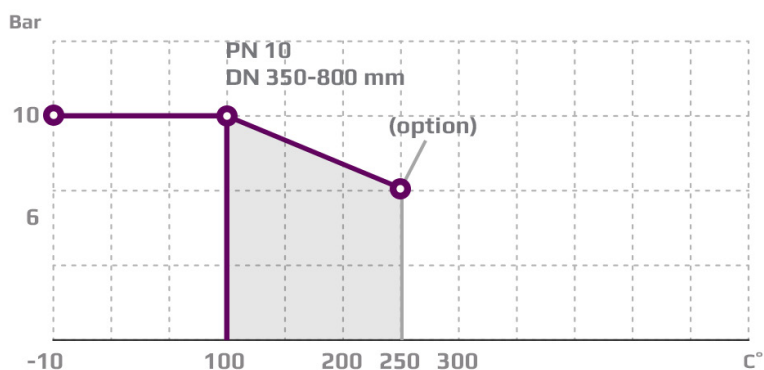
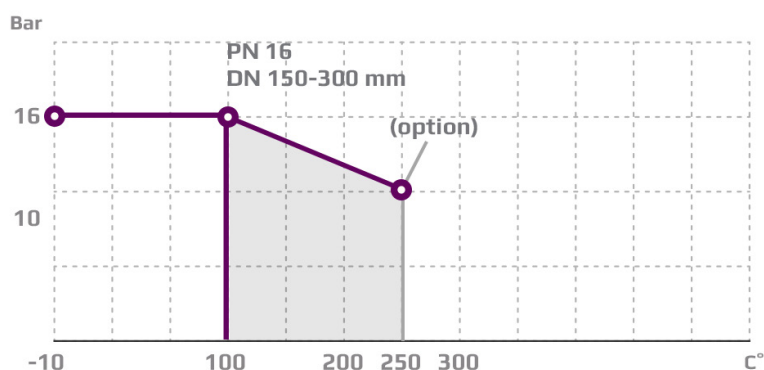

PORT NUMBERING

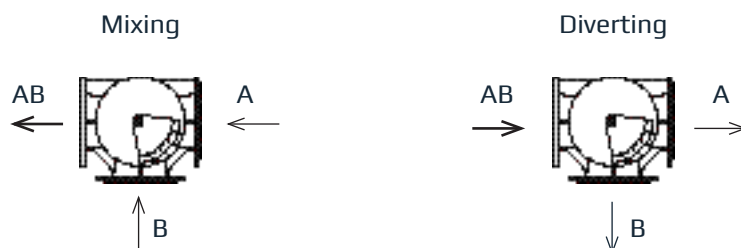

MOUNTING

The valve connections are marked A, B and AB. The slide is operating between A and B. Check slide position before installation in the pipe. The slide position is marked on the top of the shaft. The valves can be installed with vertical as well as horizontal spindles. The valves must be mounted in a way that the valve actuator will be exposed to a minimum of moisture and unnecessary vibrations. Valves can also be supplied in AB-Right configuration (data sheet 0.2.6.02).

3-way Control Valve type G3FM-TL (AB-Left)

Nodular cast iron, PN25, DN 65 – 125 mm / PN16, DN150 - 300 mm / PN10, DN 350 - 800 mm

0-2.6.03-I

Page 3 of 4

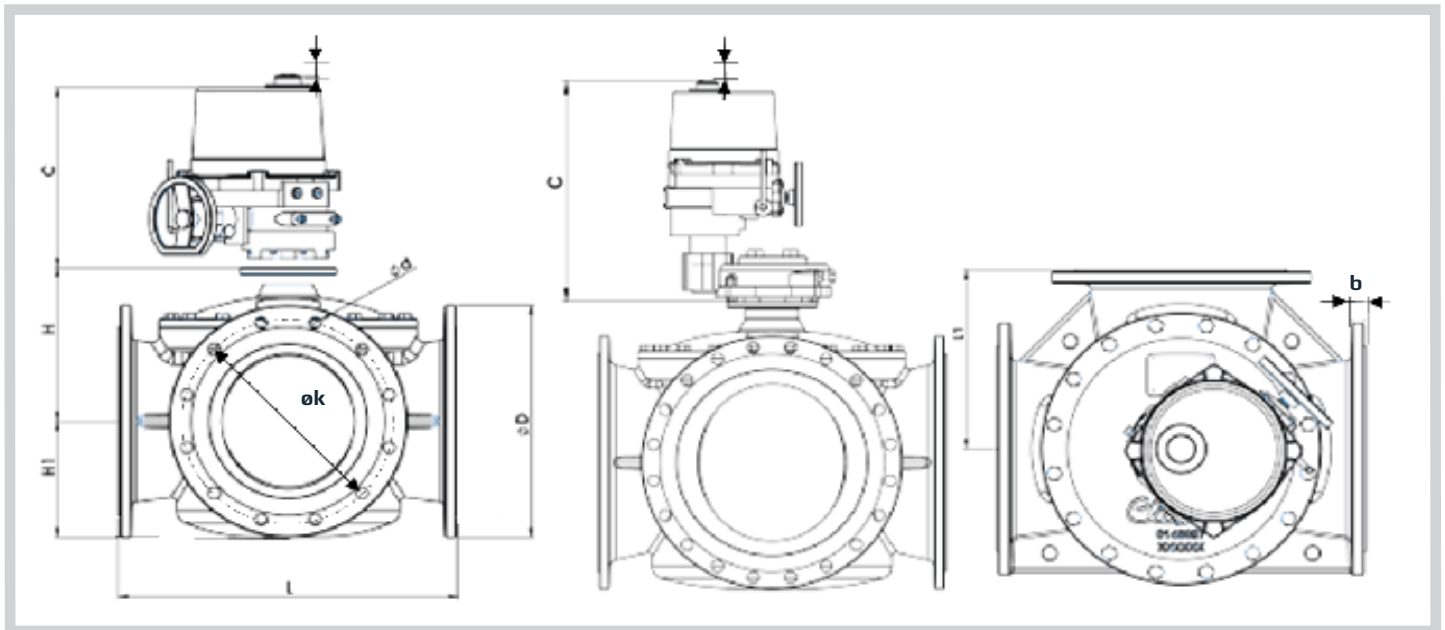

Type	EN 1092-2							ANSI Class 150			JIS B 2210 5K			JIS B 2210 10K				
	L (mm)	L1 (mm)	H (mm)	H1 (mm)	b (mm)	C (mm)	D (dia.) (mm)	k (dia.) (mm)	d mm dia. (number)	D (dia.) (mm)	k (dia.) (mm)	d mm dia. (number)	D (dia.) (mm)	k (dia.) (mm)	d mm dia. (number)	D (dia.) (mm)	k (dia.) (mm)	d mm dia. (number)
65 G3FM-TR	292	146	135	92	19	273	185	145	19x(8)	180	140	19x(4)	155	130	15x(4)	175	140	19x(4)
80 G3FM-TR	292	146	140	94	20	273	200	160	19x(8)	190	152	19x(4)	180	145	19x(4)	185	150	19x(8)
100 G3FM-TR	350	175	158	112	17	273	235	190	23x(8)	230	190.9	19x(8)	200	165	19x(8)	210	175	19x(8)
125 G3FM-TR	400	200	179	123	19	273	270	220	28x(8)	255	216	22x(8)	235	200	19x(8)	250	210	23x(8)
150 G3FM-TR	437	218.5	196	139	19	276	285	240	23x(8)	280	241	22x(8)	265	230	19x(8)	280	240	23x(8)
200 G3FM-TR	530	265	232	169	20	361	340	295	23x(12)	343	299	23x(8)	320	280	23x(8)	320	290	23x(12)
250 G3FM-TR	592	296	272	199	22	361	400	355	28x(12)	407	362	26x(12)	385	345	23x(12)	400	355	25x(12)
300 G3FM-TR	649	324.5	302	227	25	361	455	410	28x(12)	483	432	26x(12)	430	390	23x(12)	445	400	25x(16)
350 G3FM-TR	717	358.5	334.5	251.5	25	361	505	460	23x(16)	534	477	29x(12)	480	435	25x(12)	490	445	25x(16)
400 G3FM-TR	770	385	370	282	25	361	565	515	28x(16)	597	540	29x(16)	540	495	25x(16)	560	510	27x(16)
450 G3FM-TR	820	410	391	307	26	556	615	565	28x(20)	635	578	32x(16)	605	555	25x(16)	620	565	27x(20)
500 G3FM-TR	900	450	421	335	27	556	670	620	28x(20)	699	635	32x(20)	655	605	25x(20)	675	620	27x(20)
550 G3FM-TR	900	450	421	335	27	556	-	-	-	-	-	-	720	665	27x(20)	745	680	33x(20)
600 G3FM-TR	918	459	470	354	31	556	780	725	31x(20)	813	750	35x(20)	770	715	25x(20)	795	730	33x(24)
650 G3FM-TR	1050	525	534	426	37	556	-	-	-	-	-	-	825	770	27x(24)	845	780	33x(24)
800 G3FM-TR	1230	615	596	461	53	556	1085	990	34x(24) 50x(24) PN25	-	-	-	995	930	33x(24)	1020	950	33x(28)

SPECIFICATIONS

Type	Flange connection	k_{vs} -value ⁽¹⁾ Mixing valve	k_{vs} -value ⁽¹⁾ Diverting valve	Torque Nm	Weight kg
65 G3FM-TL	65	95	120	60	26
80 G3FM-TL	80	122	154	65	29
100 G3FM-TL	100	175	220	120	41
125 G3FM-TL	125	245	330	200	58
150 G3FM-TL	150	395	425	200	71
200 G3FM-TL	200	800	1100	330	114
250 G3FM-TL	250	1500	2100	525	159
300 G3FM-TL	300	2000	2650	730	207
350 G3FM-TL	350	2530	3380	980	278
400 G3FM-TL	400	3050	3950	1370	346
450 G3FM-TL	450	3680	4480	1550	433
500 G3FM-TL	500	4150	5250	1920	563
550 G3FM-TL	550	4150	5250	1920	575
600 G3FM-TL	600	4800	6050	2950	816
650 G3FM-TL	650	6700	7800	TBC	1050
800 G3FM-TL	800	6200	8000	4000	TBC

¹⁾ k_{vs} -value for port A and B 50% open.

*Torque calculated at max inlet P for:
 DN 65 - 125 = 25 Bar
 DN 150-300 = 16 Bar
 DN 350-800 = 10 Bar



3-way Control Valve type G3FMT-SL

Nodular cast iron, PN10, DN50 - 650mm

0-2.6.16-H

Page 1 of 6

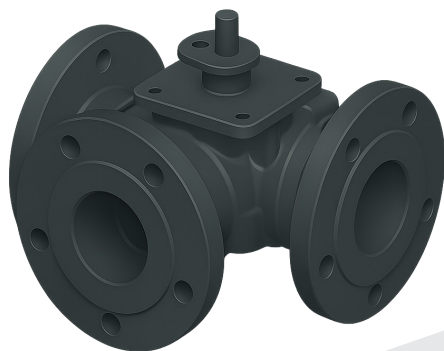

APPLICATIONS

Control valve type G3FMT-SL is a three-way control valve with a slide for quarter turn operation designed for regulating of fresh water, lubricating oil and other liquid media. The valves are designed for use in conjunction with industrial processes, district heating and marine installations with large water or lubricating oil volumes:

- Engine Jacket Cooling Water System
- Lubricating Oil Cooling
- Central Cooling Water System, etc.

The valves are designed for use in conjunction with electric actuator type CAR-H with handle for manual operation or for use in conjunction with a pneumatic actuator type VT.

DESIGN

The valve body and the valve slide are made of nodular cast iron. The valve flanges are drilled according to EN 1092-2
Option: JIS B 2210 5K/10k and ANSI class 150.

FUNCTION

The slide is firmly connected with the motor spindle. When the slide is in the one outer position by turning the spindle, connection A-AB is fully open and connection B-AB is fully closed. In the other outer position connection A-AB is fully closed and connection B-AB is fully open. In the intermediate positions the opening degrees change proportionally. The valve has a small tolerance between body and slide.

Connection described for AB-Left valves - reverse connection for AB-Right valves.

This section to be read together with sketches page 2 this data sheet.

TECHNICAL DATA

Materials:

- Valve body, slide Nodular cast iron
- O-ring NBR

Flow characteristic Almost linear

Leakage rate ANSI class I

Flanges EN 1092-2 PN 10
- Option JIS B 2210 5K/10K
ANSI class 150

Max. pressure Δp , against which the valve can close 5 bar

Nominal pressure PN 10

Design temperature 120°C

FEATURES

- Simple design secures reliable controls and reduces costly downtime
- Most compact valve on the market
- Full flexibility on port orientation AB right or AB left

Subject to change without notice.

PORT NUMBERING: AB-RIGHT



PORT NUMBERING: AB-LEFT

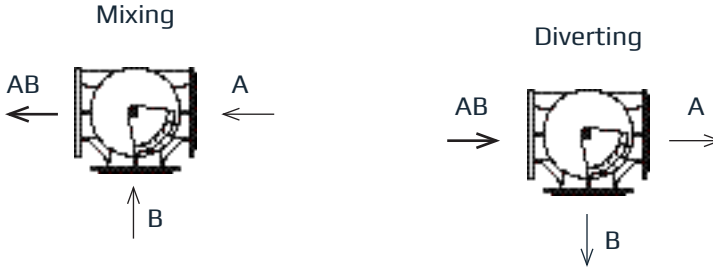

MOUNTING

The valve connections are marked A, B and AB. The slide is operating between A and B. Check slide position before installation in the pipe. The slide position is marked on the top of the shaft. The valves can be installed with vertical as well as horizontal spindles. The valves must be mounted in a way that the valve actuator will be exposed to a minimum of moisture and unnecessary vibrations.

3-way Control Valve type G3FMT-SL

Nodular cast iron, PN10, DN50 - 650mm

O-2.6.16-H

Page 3 of 6

DIMENSION SKETCH

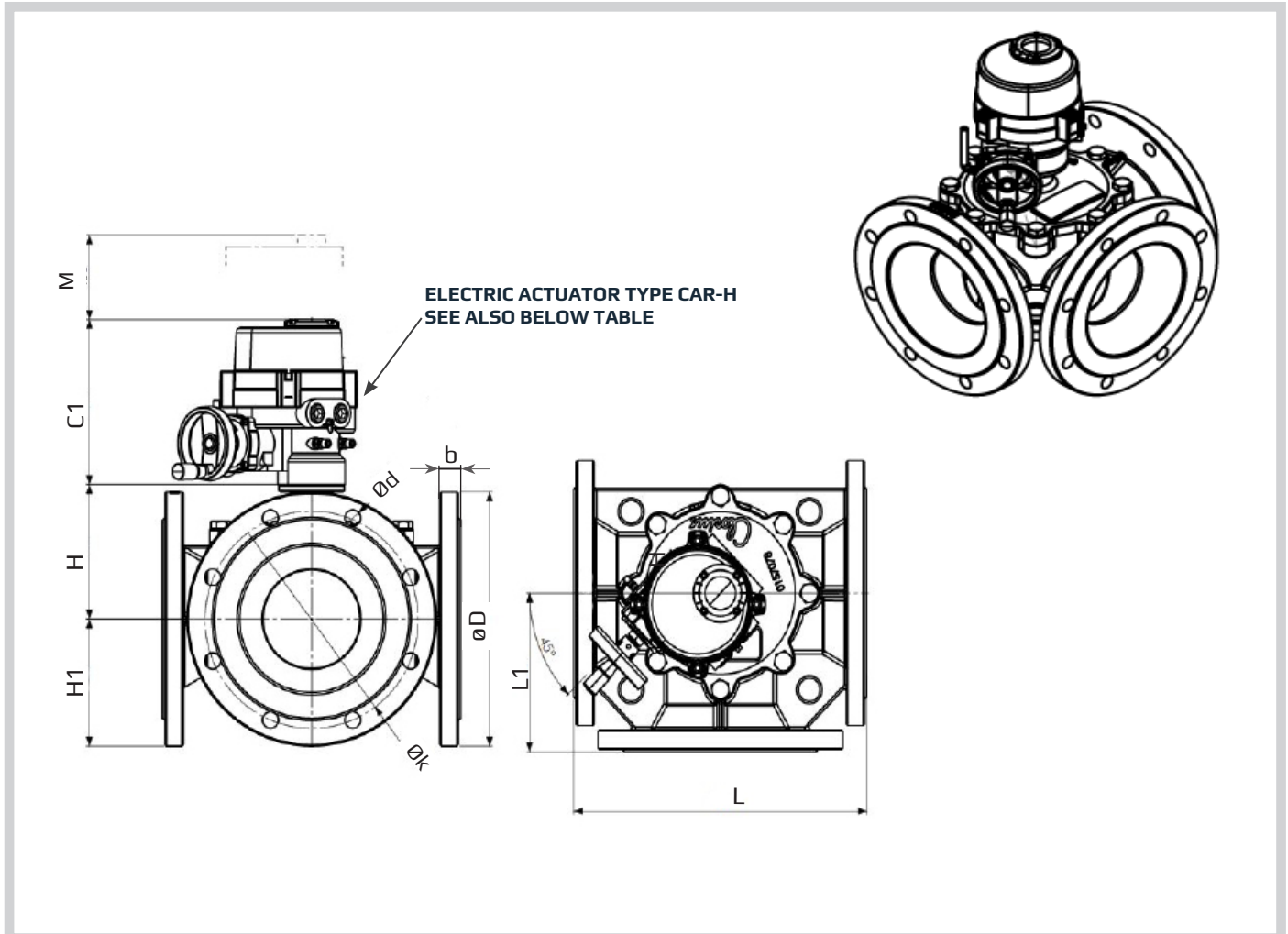

To be read together with table 1 on page 4

SPECIFICATIONS - TABLE 1 (read this together with sketch on page 3)

Type	L (mm)	L1 (mm)	H (mm)	H1 (mm)	b (mm)	C1 (mm)	M (mm)	Electric Actuator Type CAR-H
50 G3FMT-SL (HF)	254	127	114,5	ØD/2	19	223	110	CAR-H 006
65 G3FMT-SL	254	127	114,5	ØD/2	19	223	110	CAR-H 006
65 G3FMT-SL (HF)	254	127	125,5	ØD/2	19	223	110	CAR-H 006
80 G3FMT-SL	254	127	125,5	ØD/2	19	223	110	CAR-H 006
80 G3FMT-SL (HF)	254	127	130,5	ØD/2	19	223	110	CAR-H 006
100 G3FMT-SL	296	148	130,5	ØD/2	24	223	110	CAR-H 006
100 G3FMT-SL (HF)	296	148	134,5	ØD/2	24	223	110	CAR-H 006
125 G3FMT-SL	330	165	139,5	ØD/2	24	223	110	CAR-H 006
125 G3FMT-SL JI55K	320	160	139,5	ØD/2	19	223	110	CAR-H 006
150 G3FMT-SL	356	178	148,5	ØD/2	25,4	223	110	CAR-H 006
200 G3FMT-SL	410	205	181,5	ØD/2	28,4	223	110	CAR-H 010
250 G3FMT-SL	480	240	202	ØD/2	31	223	110	CAR-H 010
300 G3FMT-SL (RF)	580	290	202	ØD/2	32	223	110	CAR-H 010
300 G3FMT-SL	560	280	237	ØD/2	32	261	150	CAR-H 020
350 G3FMT-SL	660	330	256	ØD/2	36	261	150	CAR-H 024
400 G3FMT-SL	720	360	277,5	ØD/2	38	315	180	CAR-H 035
400 G3FMT-SL (HF)	720	360	314	ØD/2	25	315	180	CAR-H 035
450 G3FMT-SL	780	390	314	ØD/2	26	315	180	CAR-H 035
500 G3FMT-SL	840	420	320	ØD/2	32	315	180	CAR-H 050
550 G3FMT-SL	840	420	320	ØD/2	32	315	180	CAR-H 050
600 G3FMT-SL	950	475	339	ØD/2	32	352	200	CAR-H 080
650 G3FMT-SL	950	475	339	ØD/2	32	352	200	CAR-H 080

 RF = Reduced Flow
 HF = High Flow

ØD/2 - Depends on flange type (see also table 2)

3-way Control Valve type G3FMT-SL

Nodular cast iron, PN10, DN50 - 650mm

0-2.6.16-H

Page 5 of 6

SPECIFICATIONS - TABLE 2 Flange connections	EN 1092-2			ANSI Class 150			JIS B 2210 5K			JIS B 2210 10K		
	D (dia.) (mm)	k (dia.) (mm)	d mm dia. (number)	D (dia.) (mm)	k (dia.) (mm)	d mm dia. (number)	D (dia.) (mm)	k (dia.) (mm)	d mm dia. (number)	D (dia.) (mm)	k (dia.) (mm)	d mm dia. (number)
DN50	165	125	19x(4)	152	121	19x(4)	130	105	15x(4)	155	120	19x(4)
DN65	185	145	19x(4)	178	140	19x(4)	155	130	15x(4)	175	140	19x(4)
DN80	200	160	19x(8)	190	152	19x(4)	180	145	19x(4)	185	150	19x(8)
DN100	220	180	19x(8)	230	191	19x(8)	200	165	19x(8)	210	175	19x(8)
DN125	250	210	19x(8)	255	216	22x(8)	235	200	19x(8)	250	210	23x(8)
DN150	285	240	23x(8)	280	241	22x(8)	265	230	19x(8)	280	240	23x(8)
DN200	343	295	22x(8)	343	298	22x(8)	320	280	23x(8)	330	290	23x(12)
DN250	405	350	23x(12)	405	362	25x(12)	385	345	23x(12)	400	355	25x(12)
DN300	455	400	23x(12)	483	432	25x(12)	430	390	23x(12)	445	400	25x(16)
DN350	505	460	23x(16)	533	476	29x(12)	480	435	25x(12)	490	445	25x(16)
DN400	565	515	28x(16)	597	540	29x(16)	540	495	25x(16)	560	510	27x(16)
DN450	620	565	28x(20)	620	578	32x(16)	620	555	25x(16)	620	565	27x(20)
DN500	670	620	28x(20)	699	635	32x(20)	655	605	25x(20)	675	620	27x(20)
DN550	-	-	-	-	-	-	720	665	27x(20)	745	680	33x(20)
DN600	780	725	31x(20)	813	749	22x(8)	770	715	27x(20)	795	730	33x(24)
DN650	-	-	-	-	-	-	825	770	27x(24)	845	780	33x(24)

SPECIFICATIONS - TABLE 3

Type	Flange connection	KvS m ³ /h	Torque Nm	Weight kg
DN50 (HF)	50	67	30	16
DN65	65	67	30	18
DN65 (HF)	65	120	35	19
DN80	80	100	35	21
DN80 (HF)	80	180	38	21
DN100	100	180	38	26
DN100 (HF)	100	270	40	28
DN125	125	260	40	34
DN150	150	430	45	42
DN200	200	770	90	67
DN250	250	1.230	115	96
DN300 (RF)	300	1.190	115	142
DN300	300	2.030	160	130
DN350	350	2.850	210	175
DN400	400	3.760	265	230
DN400 (HF)	400	5.200	330	212
DN450	450	4.600	330	230
DN500	500	5.400	400	250
DN550	550	5.400	400	270
DN600	600	5.760	550	440
DN650	650	5.890	550	480

*Torque calculated at max ΔP for: DN50 - 650 - 5 Bar

**NOTE: KvS is max. KvS value

RF = Reduced Flow

HF = High Flow

3-way Control Valve type G3FMT-ULL (Ultra Low Leakage)

Nodular cast iron, PN10, DN50 - 450mm

0-2.6.15-J

Page 1 of 6

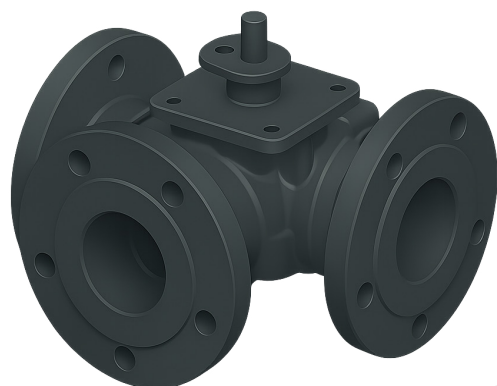

APPLICATIONS

Control valve type G3FMT-ULL is a three-way control valve with a slide for quarter turn operation designed for regulating of fresh water, lubricating oil and other liquid media. The valves are designed for use in conjunction with industrial processes, district heating and marine installations with large water or lubricating oil volumes:

- Engine Jacket Cooling Water System
- Lubricating Oil Cooling
- Central Cooling Water System, etc.

The valves are designed for use in conjunction with electric actuator type CAR-H with handle for manual operation or for use in conjunction with a pneumatic actuator type VT.

DESIGN

The valve body and the valve slide are made of nodular cast iron. The valve flanges are drilled according to EN 1092-2. Option: JIS B 2210 5K/10K and ANSI class 150.

FUNCTION

The slide is firmly connected with the motor spindle. When the slide is in the one outer position by turning the spindle, connection A-AB is fully open and connection B-AB is fully closed. In the other outer position connection A-AB is fully closed and connection B-AB is fully open. In the intermediate positions the opening degrees change proportionally. The valve has a small tolerance between body and slide. PTFE sealing element and O-ring are mounted in the slider groove to minimize leakage.

Connection described for AB-Left valves - reverse connection for AB-Right valves.

This section to be read together with sketches page 2 this data sheet.

TECHNICAL DATA

Materials:

- Valve body, slide Nodular cast iron

- Sealing element and O-ring: Silicone/PTFE

Flow characteristic Almost linear

Leakage rate ANSI class IV/EN 1349
< 0.01%

Flanges EN 1092-2 PN 10
- Option JIS B 2210K/10K
ANSI class 150

Max. pressure Δp , against which the valve can close 5 bar

Nominal pressure PN 10

Design temperature 120°C

Optional temperature 150°C

FEATURES

- Simple design secures reliable controls and reduces costly downtime
- Ultra Low Leakage rate secures energy savings - Best in class
- Most compact valve on the market
- Full flexibility on port orientation on AB right or AB left

Subject to change without notice.

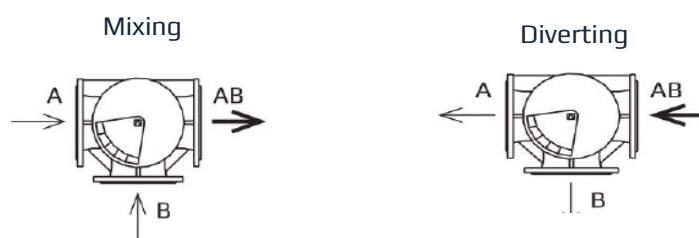
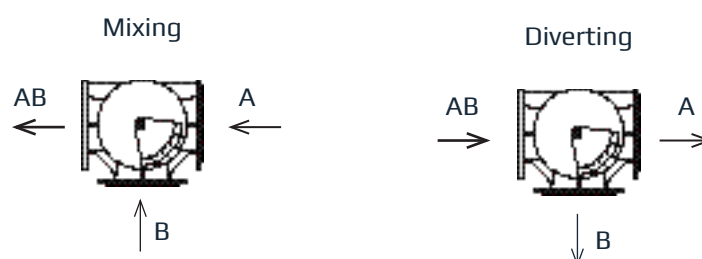
PORT NUMBERING: AB-RIGHT

PORT NUMBERING: AB-LEFT

MOUNTING

The valve connections are marked A, B and AB. The slide is operating between A and B. Check slide position before installation in the pipe. The slide position is marked on the top of the shaft. The valves can be installed with vertical as well as horizontal spindles. The valves must be mounted in a way that the valve actuator will be exposed to a minimum of moisture and unnecessary vibrations.

3-way Control Valve type G3FMT-ULL (Ultra Low Leakage)

Nodular cast iron, PN10, DN50 - 450mm

0-2.6.15-J

Page 3 of 6

DIMENSION SKETCH

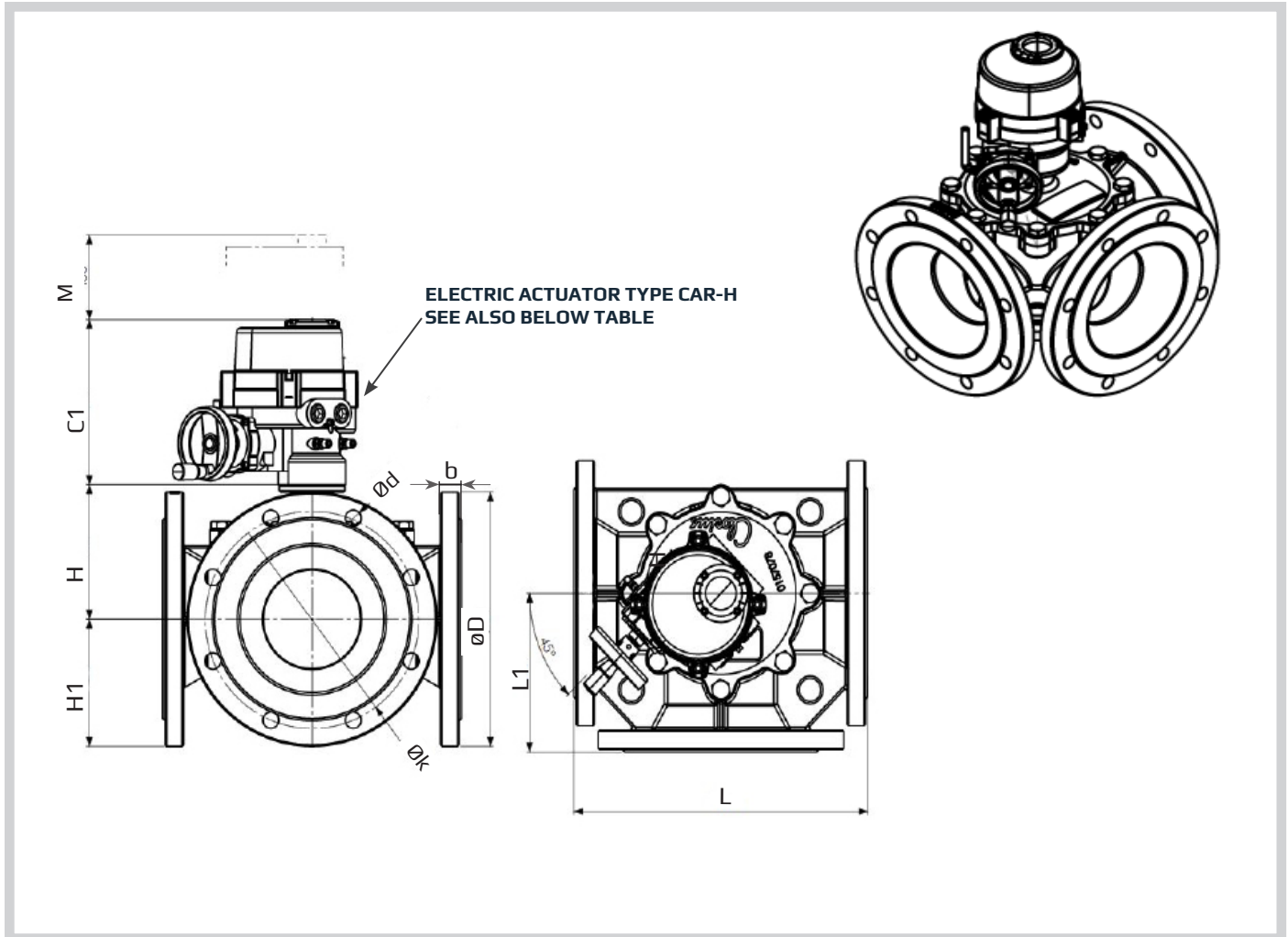

To be read together with table 1 on page 4

SPECIFICATIONS - TABLE 1 (read this together with sketch on page 3)

Type	L (mm)	L1 (mm)	H (mm)	H1 (mm)	b (mm)	C1 (mm)	M (mm)	Electric Actuator Type CAR-H
50 G3FMT-ULL (HF)	254	127	115	ØD/2	19	223	110	CAR-H 006
65 G3FMT-ULL	254	127	115	ØD/2	19	223	110	CAR-H 006
65 G3FMT-ULL (HF)	254	127	126	ØD/2	19	223	110	CAR-H 006
80 G3FMT-ULL	254	127	126	ØD/2	19	223	110	CAR-H 006
80 G3FMT-ULL (HF)	254	127	131	ØD/2	19	223	110	CAR-H 006
100 G3FMT-ULL	296	148	131	ØD/2	24	223	110	CAR-H 006
100 G3FMT-ULL (HF)	296	148	140	ØD/2	24	223	110	CAR-H 006
125 G3FMT-ULL	330	165	140	ØD/2	24	223	110	CAR-H 006
125 G3FMT-ULL (JIS5K)	320	160	140	ØD/2	19	223	110	CAR-H 006
150 G3FMT-ULL	356	178	149	ØD/2	25,4	223	110	CAR-H 010
200 G3FMT-ULL	410	205	182	ØD/2	28,4	261	150	CAR-H 016
250 G3FMT-ULL	480	240	202	ØD/2	31	261	150	CAR-H 016
300 G3FMT-ULL (RF)	580	290	202	ØD/2	32	261	150	CAR-H 016
300 G3FMT-ULL	560	280	237	ØD/2	32	315	180	CAR-H 035
350 G3FMT-ULL	660	330	256	ØD/2	36	315	180	CAR-H 050
400 G3FMT-ULL	720	360	278	ØD/2	38	315	180	CAR-H 050
400 G3FMT-ULL (HF)	720	360	314	ØD/2	25	352	200	CAR-H 080
450 G3FMT-ULL	780	390	314	ØD/2	26	352	200	CAR-H 080

 RF = Reduced Flow
 HF = High Flow

ØD/2 - Depends on flange type (see also table 2)

3-way Control Valve type G3FMT-ULL (Ultra Low Leakage)

Nodular cast iron, PN10, DN50 - 450mm

O-2.6.15-J

Page 5 of 6

SPECIFICATIONS - TABLE 2

Flange connections	EN 1092-2			ANSI Class 150			JIS B 2210 5K			JIS B 2210 10K		
	D (dia.) (mm)	k (dia.) (mm)	d mm dia. (number)	D (dia.) (mm)	k (dia.) (mm)	d mm dia. (number)	D (dia.) (mm)	k (dia.) (mm)	d mm dia. (number)	D (dia.) (mm)	k (dia.) (mm)	d mm dia. (number)
DN50	165	125	19x(4)	152	121	19x(4)	130	105	15x(4)	155	120	19x(4)
DN65	185	145	19x(4)	178	140	19x(4)	155	130	15x(4)	175	140	19x(4)
DN80	200	160	19x(8)	190	152	19x(4)	180	145	19x(4)	185	150	19x(8)
DN100	220	180	19x(8)	230	191	19x(8)	200	165	19x(8)	210	175	19x(8)
DN125	250	210	19x(8)	255	216	22x(8)	235	200	19x(8)	250	210	23x(8)
DN150	285	240	23x(8)	280	241	22x(8)	265	230	19x(8)	280	240	23x(8)
DN200	343	295	22x(8)	343	298	22x(8)	320	280	23x(8)	330	290	23x(12)
DN250	405	350	23x(12)	405	362	25x(12)	385	345	23x(12)	400	355	25x(12)
DN300	455	400	23x(12)	483	432	25x(12)	430	390	23x(12)	445	400	25x(16)
DN350	505	460	23x(16)	533	476	29x(12)	480	435	25x(12)	490	445	25x(16)
DN400	565	515	28x(16)	597	540	29x(16)	540	495	25x(16)	560	510	27x(16)
DN450	620	565	28x(20)	620	578	32x(16)	620	555	25x(16)	620	565	27X(20)

SPECIFICATIONS - TABLE 3

Type	Flange connection	KvS m ³ /h**	Torque Nm	Weight kg
DN50 (HF)	50	67	30	16
DN65	65	67	30	18
DN65 (HF)	65	120	35	19
DN80	80	100	35	21
DN80 (HF)	80	180	38	21
DN100	100	180	38	26
DN100 (HF)	100	270	40	28
DN125	125	260	40	34
DN150	150	430	90	42
DN200	200	770	120	67
DN250	250	1.230	150	95
DN300 (RF)	300	1.190	150	140
DN300	300	2.030	320	130
DN350	350	2.850	418	175
DN400	400	3.760	530	220
DN400 (HF)	400	5.200	654	212
DN450	450	4.600	654	227

*Torque calculated at max ΔP for: DN50 - 450 - 5 Bar

****NOTE: KvS is max. KvS value**

RF = Reduced Flow

HF = High Flow

3-way Control Valve type G3FMT-ULLM Ultra Low Leakage (Middle)

Nodular cast iron, PN10, DN50 - 400mm

0-2.6.17-B

Page 1 of 6

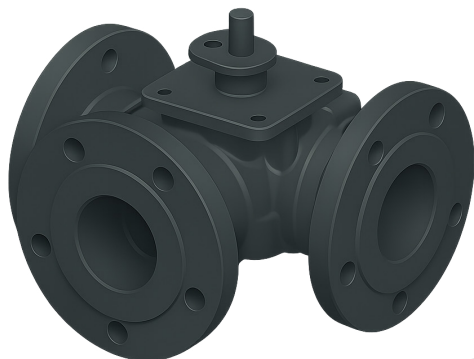

APPLICATIONS

Control valve type G3FMT-ULLM is a three-way control valve with a slide for quarter turn operation designed for regulating of fresh water, lubricating oil and other liquid media. The valves are designed for use in conjunction with industrial processes, district heating and marine installations with large water or lubricating oil volumes:

- Engine Jacket Cooling Water System
- Lubricating Oil Cooling
- Central Cooling Water System, etc.

The valves are designed for use in conjunction with valve motor type CAR -H with handle for manual operation or for use in conjunction with a pneumatic actuator type VT.

DESIGN

The valve body and the valve slide are made of nodular cast iron. The valve flanges are drilled according to EN 1092-2. Option: JIS B 2210 5K/10K and ANSI class 150.

FUNCTION

The slide is firmly connected with the motor spindle. When the slide is in the one outer position by turning the spindle, connection A-AB is fully open and connection B-AB is fully closed. In the other outer position connection A-AB is fully closed and connection B-AB is fully open.

In the intermediate positions the opening degrees change proportionally. The valve has a small tolerance between body and slide.

PTFE sealing element and O-ring are mounted in the slider groove to minimize leakage.

This section to be read together with sketches page 2 this data sheet.

TECHNICAL DATA

Materials:	
- Valve body, slide	Nodular cast iron
- Sealing element and O-ring	Silicone/PTFE
Flow characteristic	Almost linear
Leakage rate	ANSI class IV/EN 1349 < 0.01%
Flanges	EN 1092-2 PN 10
- Option	JIS B 2210 5K/10K ANSI class 150
Max. pressure Δp, against which the valve can close	5 bar
Nominal pressure	PN 10
Design temperature	120°C
Optional temperature	150°C

FEATURES

- Simple design secures reliable controls and reduces costly downtime
- Ultra Low Leakage rate secures energy savings - Best in class
- Most compact valve on the market
- Full flexibility on port orientation on AB right or AB left

Subject to change without notice.

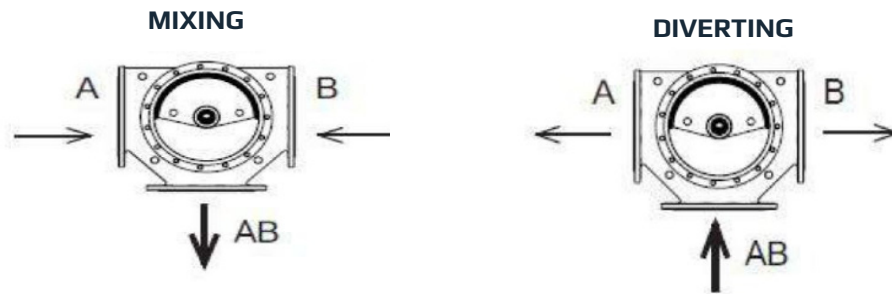
PORT NUMBERING: AB-MIDDLE**MOUNTING**

The valve connections are marked A, B and AB. The slide is operating between A and B. Check slide position before installation in the pipe. The slide position is marked on the top of the shaft. The valves can be installed with vertical as well as horizontal spindles. The valves must be mounted in a way that the valve actuator will be exposed to a minimum of moisture and unnecessary vibrations.

3-way Control Valve type G3FMT- ULLM Ultra Low Leakage (Middle)

Nodular cast iron, PN10, DN50 - 400mm

0-2.6.17-B

Page 3 of 6

DIMENSION SKETCH

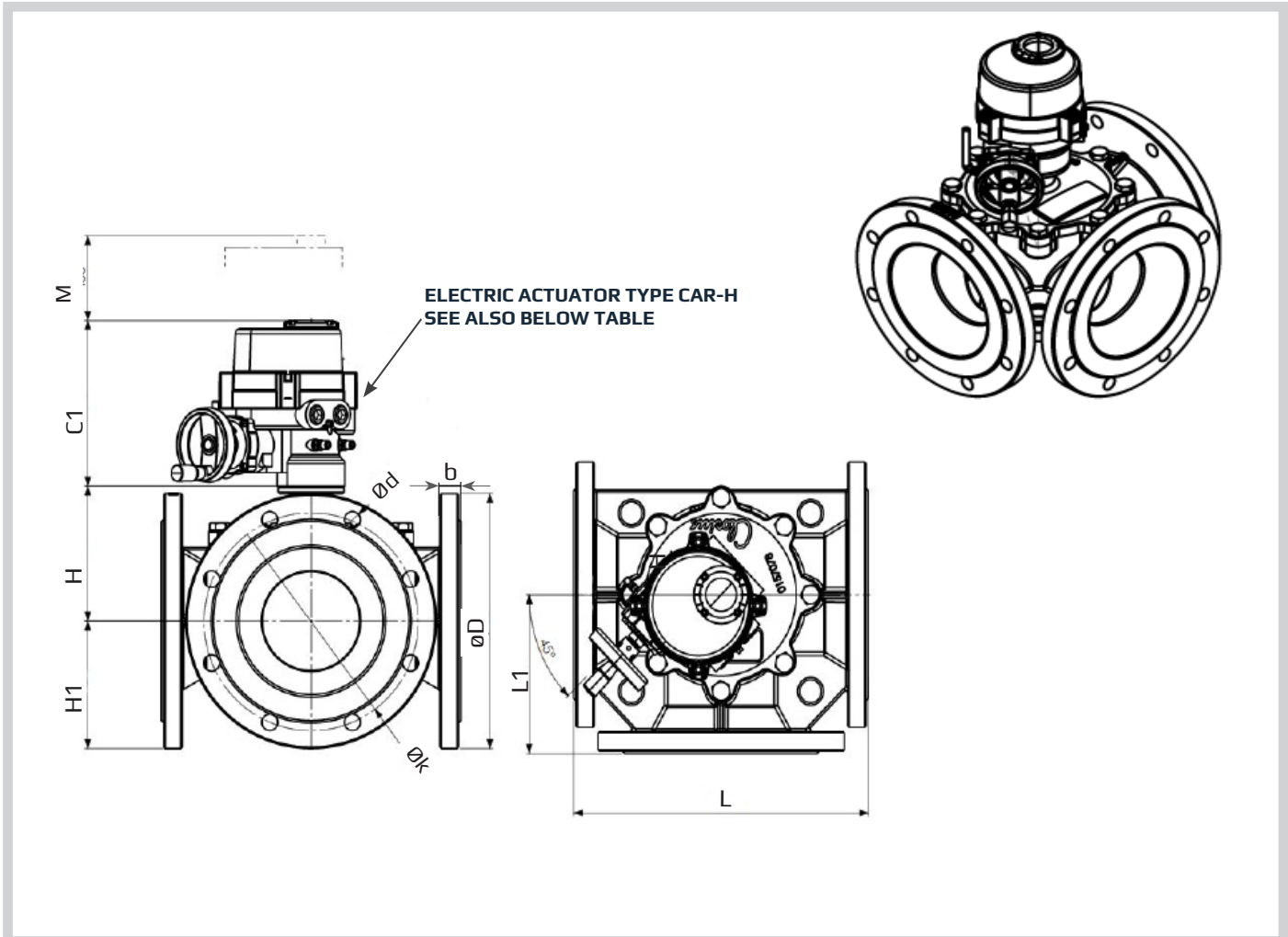

To be read together with table 1 on page 4

SPECIFICATIONS - TABLE 1 (read this together with table on page 4)

Type	L (mm)	L1 (mm)	H (mm)	H1 (mm)	b (mm)	C1 (mm)	M (mm)	Electric Actuator Type CAR-H
50 G3FMT - ULLM(HF)	254	127	115	ØD/2	19	223	110	CAR-H 006
65 G3FMT-ULLM	254	127	115	ØD/2	19	223	110	CAR-H 006
65 G3FMT-ULLM (HF)	254	127	126	ØD/2	19	223	110	CAR-H 006
80 G3FMT-ULLM	254	127	126	ØD/2	19	223	110	CAR-H 006
80 G3FMT-ULLM (HF)	254	127	131	ØD/2	19	223	110	CAR-H 006
100 G3FMT-ULLM	296	148	131	ØD/2	24	223	110	CAR-H 006
100 G3FMT-ULLM (HF)	296	148	140	ØD/2	24	223	110	CAR-H 006
125 G3FMT-ULLM	330	165	140	ØD/2	24	223	110	CAR-H 006
125 G3FMT-ULLM (JIS5K)	320	160	140	ØD/2	19	223	110	CAR-H 006
150 G3FMT-ULLM	356	178	149	ØD/2	25,4	223	110	CAR-H 010
200 G3FMT-ULLM	410	205	182	ØD/2	28,4	261	150	CAR-H 016
250 G3FMT-ULLM	480	240	202	ØD/2	31	261	150	CAR-H 020
300 G3FMT-ULLM	560	280	237	ØD/2	32	315	180	CAR-H 050
350 G3FMT-ULLM	660	330	256	ØD/2	36	315	180	CAR-H 050
400 G3FMT-ULLM	720	360	278	ØD/2	38	315	180	CAR-H 080

ØD/2 - Depends on flange type (see also table 2)

HF = High Flow



3-way Control Valve type G3FMT- ULLM Ultra Low Leakage (Middle)

Nodular cast iron, PN10, DN50 - 400mm

0-2.6.17-B

Page 5 of 6

SPECIFICATIONS - TABLE 2

Flange connections	EN 1092-2			ANSI Class 150			JIS B 2210 5K			JIS B 2210 10K		
	D (dia.) (mm)	k (dia.) (mm)	d mm dia. (number)	D (dia.) (mm)	k (dia.) (mm)	d mm dia. (number)	D (dia.) (mm)	k (dia.) (mm)	d mm dia. (number)	D (dia.) (mm)	k (dia.) (mm)	d mm dia. (number)
DN50	165	125	19x(4)	152	124	19x(4)	130	105	19x(4)	155	120	19x(4)
DN65	185	145	19x(4)	178	140	19x(4)	155	130	19x(4)	175	140	19x(4)
DN80	200	160	19x(8)	190	152	19x(4)	180	145	19x(4)	185	150	19x(8)
DN100	220	180	19x(8)	230	191	19x(8)	200	165	19x(8)	210	175	19x(8)
DN125	250	210	19x(8)	255	216	22x(8)	235	200	19x(8)	250	210	23x(8)
DN150	285	240	23x(8)	280	241	22x(8)	265	230	19x(8)	280	240	23x(8)
DN200	343	295	22x(8)	343	298	22x(8)	320	280	23x(8)	330	290	23x(12)
DN250	405	350	23x(12)	405	362	25x(12)	385	345	23x(12)	400	355	25x(12)
DN300	455	400	23x(12)	483	432	25x(12)	430	390	23x(12)	445	400	25x(16)
DN350	505	460	23x(16)	533	476	29x(12)	480	435	25x(12)	490	445	25x(16)
DN400	565	515	28x(16)	597	540	29x(16)	540	495	25x(16)	560	510	27x(16)

SPECIFICATIONS - TABLE 3

Type	Flange connection	KvS m ³ /h	Torque Nm	Weight kg
DN50 (HF)	50	N/A	N/A	N/A
DN65	65	N/A	N/A	N/A
DN 65 (HF)	65	N/A	N/A	N/A
DN80	80	75	35	21,5
DN80 (HF)	80	N/A	N/A	N/A
DN100	100	120	38	27
DN100 (HF)	100	175	40	29,5
DN125	125	165	40	36
DN150	150	310	90	44,5
DN200	200	550	120	71
DN250	250	N/A	N/A	N/A
DN300	300	N/A	N/A	N/A
DN350	350	N/A	N/A	N/A
DN400	400	N/A	N/A	N/A

*Torque calculated at max ΔP for: DN50 - 400 - 5 Bar

**NOTE: KvS is max. KvS value

HF = High Flow

N/A = coming soon

3-way Control Valve type G3FMT-SLM (Middle)

Nodular cast iron, PN10, DN80, 100, 125, 150, 200, 250, 300, 350 & 400mm

O-2.6.18-B

Page 1 of 4

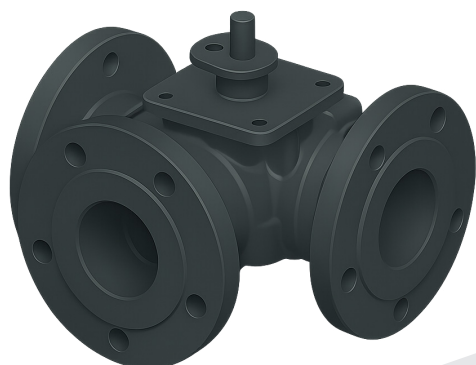

APPLICATIONS

Control valve type G3FMT-SLM is a three-way control valve with a slide for quarter turn operation designed for regulating of fresh water, lubricating oil and other liquid media. The valves are designed for use in conjunction with industrial processes, district heating and marine installations with large water or lubricating oil volumes:

- Engine Jacket Cooling Water System
- Lubricating Oil Cooling
- Central Cooling Water System, etc.

The valves are designed for use in conjunction with electric actuator type CAR-H with handle for manual operation or for use in conjunction with a pneumatic actuator type VT.

DESIGN

The valve body and the valve slide are made of nodular cast iron. The valve flanges are drilled according to EN 1092-2. Option: JIS B 2210 5K/10k and ANSI class 150.

FUNCTION

The slide is firmly connected with the motor spindle. When the slide is in the one outer position by turning the spindle, connection A-AB is fully open and connection B-AB is fully closed. In the other outer position connection A-AB is fully closed and connection B-AB is fully open. In the intermediate positions the opening degrees change proportionally. The valve has a small tolerance between body and slide.

This section to be read together with sketches page 2 this data sheet.

TECHNICAL DATA

Materials:	
- Valve body, slide	Nodular cast iron EN-GJS-400-15
- O-ring	NBR
Flow characteristic	Almost linear
Leakage rate	ANSI class I
Flanges	EN 1092-2 PN 10
- Option	JIS B 2210 5K/10K ANSI class 150
Max. pressure Δp, against which the valve can close	5 bar
Nominal pressure	PN 10
Design temperature	120°C

FEATURES

- Simple design secures reliable controls and reduces costly downtime
- Most compact valve on the market
- Full flexibility on port orientation

Subject to change without notice.

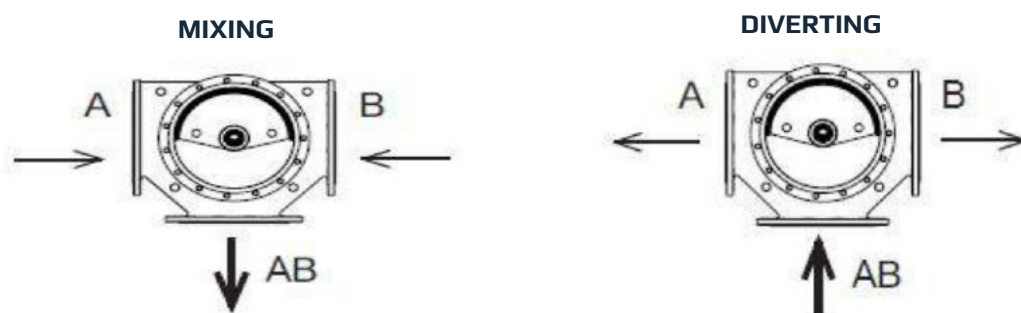
PORT NUMBERING: AB-MIDDLE**MOUNTING**

The valve connections are marked A, B and AB. The slide is operating between A and B. Check slide position before installation in the pipe. The slide position is marked on the top of the shaft. The valves can be installed with vertical as well as horizontal spindles. The valves must be mounted in a way that the valve actuator will be exposed to a minimum of moisture and unnecessary vibrations.

3-way Control Valve type G3FMT-SLM (Middle)

Nodular cast iron, PN10, DN80,100, 125, 150, 200, 250, 300, 350 & 400mm

O-2.6.18-B

Page 3 of 4

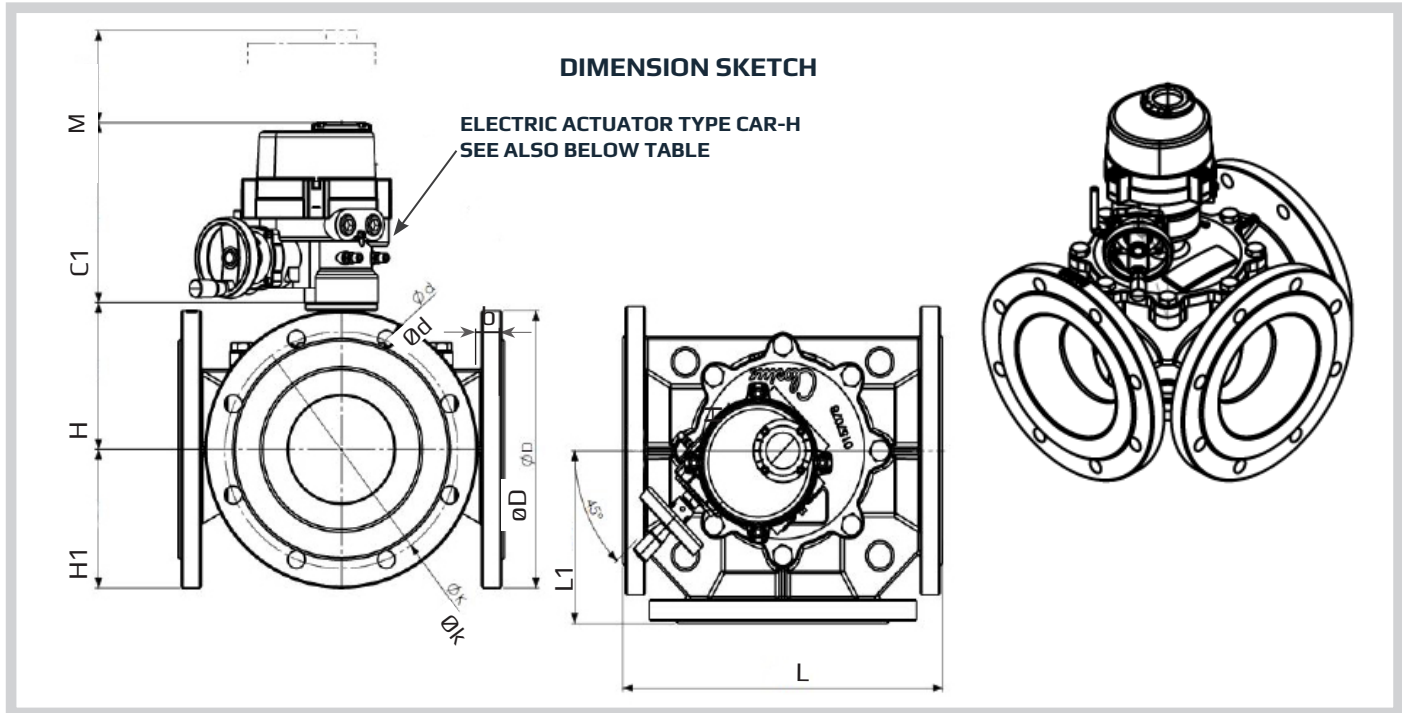

SPECIFICATIONS - TABLE 1 (read this together with table on page 4)

Type	L (mm)	L1 (mm)	H (mm)	H1 (mm)	b (mm)	C1 (mm)	M (mm)	Electric Actuator Type CAR-H
DN80 G3FMT-SLM	254	127	125,5	ØD/2	19	223	110	CAR-H 006
DN80 G3FMT-SLM (HF)	254	127	130,5	ØD/2	19	223	110	CAR-H 006
DN100 G3FMT-SLM	254	127	134,5	ØD/2	19	223	110	CAR-H 006
100 G3FMT-SLM (HF)	296	148	140	ØD/2	24	223	110	CAR-H 006
125 G3FMT-SLM	330	165	140	ØD/2	24	223	110	CAR-H 006
125 G3FMT-SLMJIS5K	320	160	140	ØD/2	19	223	110	CAR-H 006
150 G3FMT-SLM	356	178	149	ØD/2	25,4	223	110	CAR-H 010
200 G3FMT-SLM	410	205	182	ØD/2	28,4	261	150	CAR-H 010
250 G3FMT-SLM	480	240	202	ØD/2	31	261	150	CAR-H 010
DN300 G3FMT-SLM	580	290	202	ØD/2	32	223	110	CAR-H 010
DN350 G3FMT-SLM	660	330	256	ØD/2	36	261	150	CAR-H 024
DN400 G3FMT-SLM	720	360	278	ØD/2	38	315	180	CAR-H 035
DN400 G3FMT-SLM (HF)	720	360	278	ØD/2	38	315	180	CAR-H 035

ØD/2 - Depends on flange type (see also table 2)
HF = High Flow

SPECIFICATIONS - TABLE 2

Flange connections	EN 1092-2			ANSI Class 150			JIS B 2210 5K			JIS B 2210 10K		
	D (dia.) (mm)	k (dia.) (mm)	d mm dia. (number)	D (dia.) (mm)	k (dia.) (mm)	d mm dia. (number)	D (dia.) (mm)	k (dia.) (mm)	d mm dia. (number)	D (dia.) (mm)	k (dia.) (mm)	d mm dia. (number)
DN100	220	180	19x(8)	230	191	19x(8)	200	165	19x(8)	210	175	19x(8)
DN125	250	210	19x(8)	255	216	22x(8)	235	200	19x(8)	250	210	23x(8)
DN150	285	240	23x(8)	280	241	22x(8)	265	230	19x(8)	280	240	23x(8)
DN200	343	295	22x(8)	343	298	22x(8)	320	280	23x(8)	330	290	23x(12)
DN250	405	350	23x(12)	405	362	25x(12)	385	345	23x(12)	400	355	25x(12)
DN300	455	400	23x(12)	483	432	25x(12)	480	390	23x(12)	445	400	25x(16)
DN350	505	460	23x(16)	533	476	29x(12)	480	435	25x(12)	490	445	25x(16)
DN400	565	515	28x(16)	597	540	29x(16)	540	495	25x(16)	560	510	27x(16)

SPECIFICATIONS - TABLE 3

Type	Flange connection	KvS m ³ /h	Torque Nm	Weight kg
DN80	80	-	-	-
DN80 (HF)	-	-	-	-
DN100	100	-	-	-
DN100 (HF)	100	179	40	30
DN125	125	179	40	36
DN150	150	310	45	44,5
DN200	200	550	90	71
DN250	250	830	115	102
DN300	300	-	-	-
DN350	350	-	-	-
DN400	400	-	-	-
DN400 (HF)	400	3.520		221

Torque calculated at max Δ P for: DN100 - 250 - 5 Bar

HF = High Flow

**NOTE: KvS is max. KvS value



3-way Control Valve type G3FM-TM (AB-Middle)

Nodular cast iron, PN16, DN 80 - 250 mm / PN10, DN 300 - 450 mm

0-2.6.03.02-D

Page 1 of 4



APPLICATIONS

Control valve type G3FM-TM is a three-way control valve with a slide for quarter turn operation designed for regulating of fresh water, lubricating oil and other liquid media. The valves are designed for use in conjunction with industrial processes, district heating and marine installations with large water or lubricating oil volumes:

- Engine Jacket Cooling Water System
- Lubricating Oil Cooling
- Central Cooling Water System, etc.

The valves are designed for use in conjunction with valve motor type CAR-H with handle for manual operation or for use in conjunction with a pneumatic actuator.

DESIGN

The valve body and the valve slide are made of nodular cast iron. The valve flanges are drilled according to EN 1092-2 (JIS B 2210 option).

FUNCTION

The slide is firmly connected with the motor spindle. When the slide is in the one outer position by turning the spindle, connection A-AB is fully open and connection B-AB is fully closed. In the other outer position connection A-AB is fully closed and connection B-AB is fully open. In the intermediate positions the opening degrees change proportionally. The valve has a small tolerance between body and slide. To minimize the leakage an O-ring is mounted in a groove on the slide.

TECHNICAL DATA

Materials:

- Valve body, slide	Nodular cast iron EN-GJS-400-15
- O-ring	NBR 70A
- U-ring	PTFE
Flow characteristic	Almost linear
Leakage rate	Max. 0.5%
Regulating capability	Kvs/Kvr > 25

Flanges	EN 1092-2 PN 10/16
- Option	JIS B 2210 5K

Counter flanges (suggested for EN 1092-2) DIN 2633 – PN 16

Max. pressure Δp_L , against which the valve can close:

- DN 250 16 Bar
- DN 450 10 Bar

Nominal pressure

- DN 250 mm	PN 16, max. 100°C
- DN 450 mm	PN 10, max. 100 °C

Slide in Nodular cast iron

FEATURES

- Simple design secures reliable controls and reduces costly downtime
- Low leakage rate secures energy savings
- Flexible choice of port placement

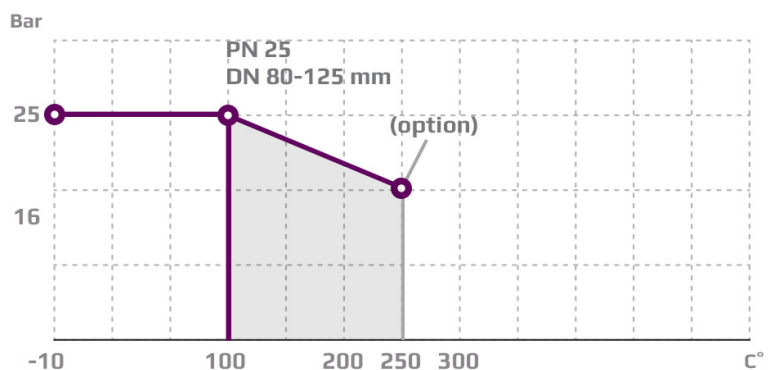

Subject to change without notice.

PRESSURE/TEMPERATURE DIAGRAM

According to DIN 2401

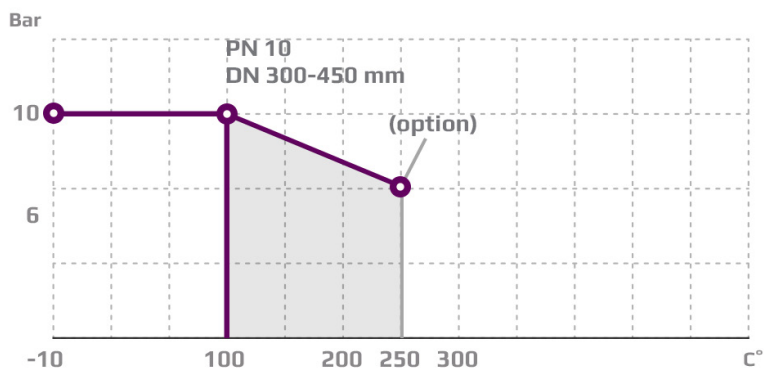
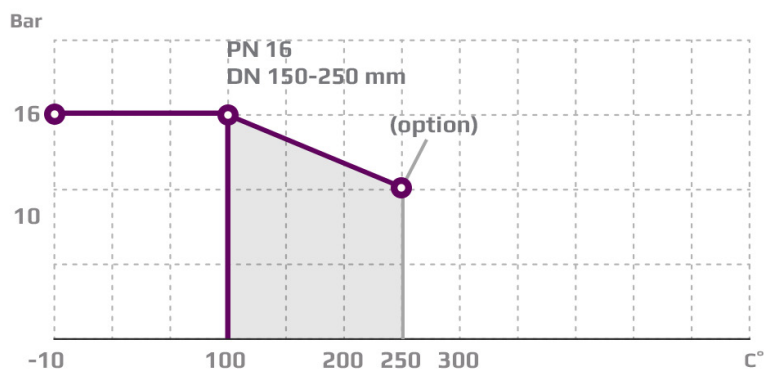

PORT NUMBERING

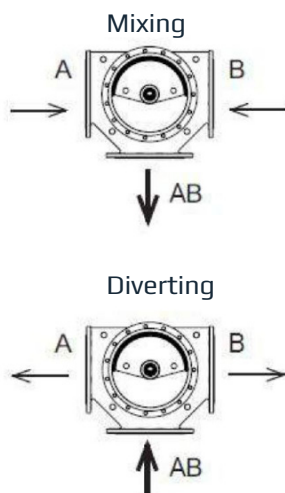

MOUNTING

The valve connections are marked A, B and AB. The slide is operating between A and B. Check slide position before installation in the pipe. The slide position is marked on the top of the shaft. The valves can be installed with vertical as well as horizontal spindles. The valves must be mounted in a way that the valve actuator will be exposed to a minimum of moisture and unnecessary vibrations. Valves can also be supplied in AB-Right configuration (data sheet 0.2.6.02.01) or AB-Left (data sheet 0.2.6.03).

3-way Control Valve type G3FM-TM (AB-Middle)

Nodular cast iron, PN16, DN 80 - 250 mm / PN10, DN 300 - 450 mm

0-2.6.03.02-D

Page 3 of 4

DIMENSION SKETCH

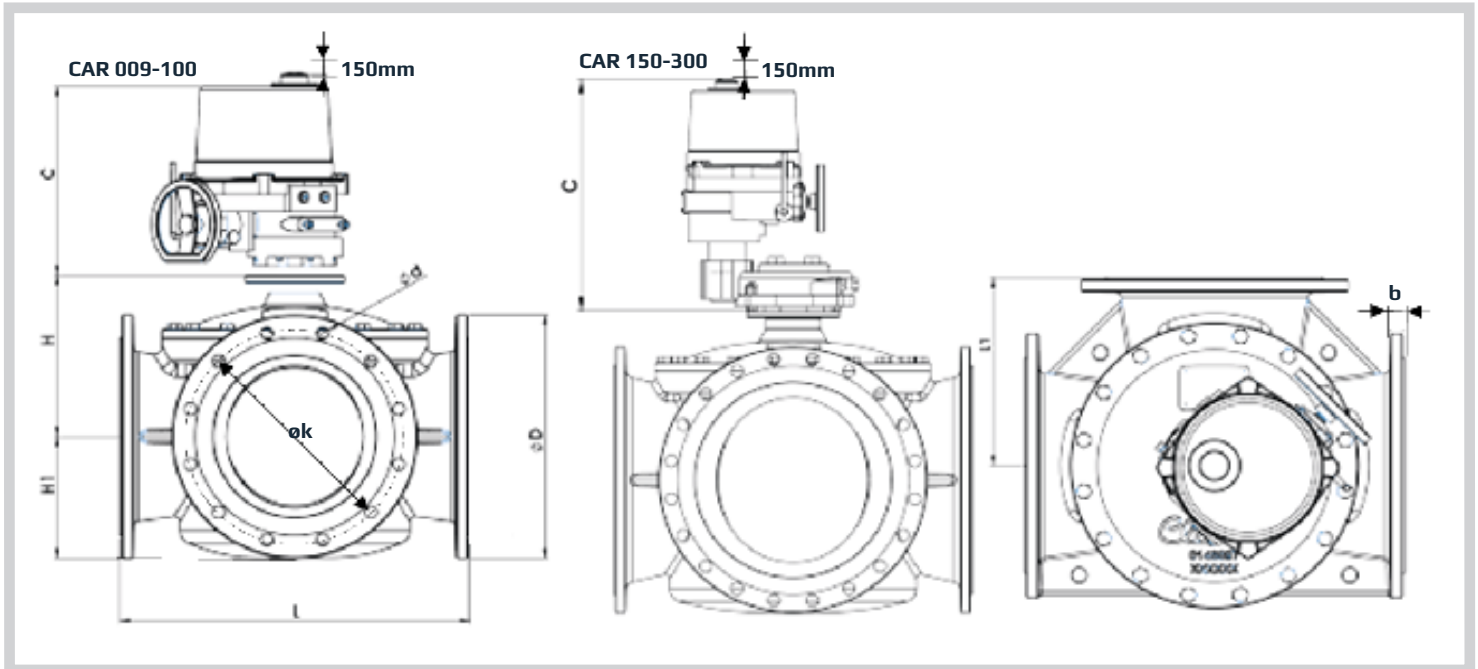

Type	L (mm)	L1 (mm)	H (mm)	H1 (mm)	b (mm)	C (mm)	EN 1092-2			ANSI Class 150			JIS B 2210 5K			JIS B 2210 10K		
							D (dia.) (mm)	k (dia.) (mm)	d mm dia. (number)	D (dia.) (mm)	k (dia.) (mm)	d mm dia. (number)	D (dia.) (mm)	k (dia.) (mm)	d mm dia. (number)	D (dia.) (mm)	k (dia.) (mm)	d mm dia. (number)
80 G3FM-TM	292	146	140	94	20	273	200	160	19x(8)	190	190.8	19x(8)	180	145	19x(4)	185	150	19x(8)
100 G3FM-TM	350	175	158	112	17	273	235	190	23x(8)	230	190.9	19x(8)	200	165	19x(8)	210	175	19x(8)
125 G3FM-TM	400	200	179	123	19	273	270	220	28x(8)	255	216	22x(8)	235	200	19x(8)	250	210	23x(8)
150 G3FM-TM	437	218,5	196	139	19	276	285	240	23x(8)	280	241	22x(8)	265	230	19x(8)	280	240	23x(8)
200 G3FM-TM	530	265	232	169	20	361	340	295	23x(12)	343	299	23x(8)	320	280	23x(8)	320	290	23x(12)
250 G3FM-TM	592	296	272	199	22	361	400	355	28x(12)	407	362	26x(12)	385	345	23x(12)	400	355	25x(12)
300 G3FM-TM	649	324,5	302	227	25	361	455	410	28x(12)	483	432	26x(12)	430	390	23x(12)	445	400	25x(16)
350 G3FM-TM	717	358,5	334,5	251,5	25	361	505	460	23x(16)	534	477	29x(12)	480	435	25x(12)	490	445	25x(16)
400 G3FM-TM	770	385	370	282	25	361	565	515	28x(16)	597	540	29x(16)	540	495	25x(16)	560	510	27x(16)
450 G3FM-TM	820	410	391	307	26	556	615	565	28x(20)	635	578	32x(16)	605	555	25x(16)	620	565	27x(20)

SPECIFICATIONS

Type	Flange connection DN in mm	k_{vs} -value ⁽¹⁾ Mixing valve m ³ /h	k_{vs} -value ⁽¹⁾ Diverting valve m ³ /h	Torque Nm for inlet P*	Weight kg
65 G3FM-TM	65	110	127	72	20
80 G3FM-TM	80	122	154	85	29
100 G3FM-TM	100	220	248	145	41
125 G3FM-TM	125	369	437	245	58
150 G3FM-TM	150	510	600	259	71
200 G3FM-TM	200	807	1100	435	114
250 G3FM-TM	250	1500	2100	695	159
300 G3FM-TM	300	2000	2650	795	207
350 G3FM-TM	350	2530	3380	1350	278
400 G3FM-TM	400	3050	3950	TBC	346
450 G3FM-TM	450	3680	4480	2100	433

¹⁾ k_{vs} -value for port A and B 50% open.

*Torque calculated at max inlet P for:
 DN 65 - 125 = 25 Bar
 DN 150-250 = 16 Bar
 DN 300-450 = 10 Bar



3-WAY CONTROL VALVE TYPE G3CM-T

Nodular Cast Iron, PN25 DN 100 – 125 mm, PN16 DN 150 - 300 mm, Grooved Joints

0-2.6.05-B

Page 1 of 2



TECHNICAL DATA

Materials:

- Valve body, slide	EN-GJS-400-15
- O-ring	NBR 70A
- U-ring	PTFE

Flow characteristic	Almost linear
Leakage rate	Max. 0.5%
Regulating capability	Kvs/Kvr > 25

Connection	Grooved joints acc. to ANSI/AWWA C-606 (Victaulic joints)
------------	-----------------------------------------------------------------

Max. pressure Δp_L , against which the valve can close 16 bar

Nominal pressure
DN 100 - 125mm PN 25, max. 100°C (option 250°C)
DN 150 - 300mm PN 16, max. 100°C (option 250°C)

Slide in Nodular cast iron

APPLICATIONS

Control valve type G3CM-T is a three-way control valve with a slide for quarter turn operation designed for regulating of fresh water, lubricating oil and other liquid media. The valves are designed for use in conjunction with industrial processes, district heating and marine installations with large water or lubricating oil volumes:

- Engine Jacket Cooling Water System
- Lubricating Oil Cooling
- Central Cooling Water System, etc.

The valves are designed for use in conjunction with valve motor type CAR with handle for manual operation or for use in conjunction with a pneumatic actuator.

DESIGN

The valve body and the valve slide are made of nodular cast iron.

FUNCTION

The slide is firmly connected with the motor spindle. When the slide is in the one outer position by turning the spindle, connection A-AB is fully open and connection B-AB is fully closed. In the other outer position connection A-AB is fully closed and connection B-AB is fully open. In the intermediate positions the opening degrees change proportionally. The valve has a small tolerance between body and slide. To minimize the leakage an O-ring is mounted in a groove on the slide.

FEATURES

- Simple design secures reliable controls and reduces costly downtime
- Grooved ends - ready for coupling installation
- No need for counter flange

PRESSURE/TEMPERATURE DIAGRAM

According to DIN 2401

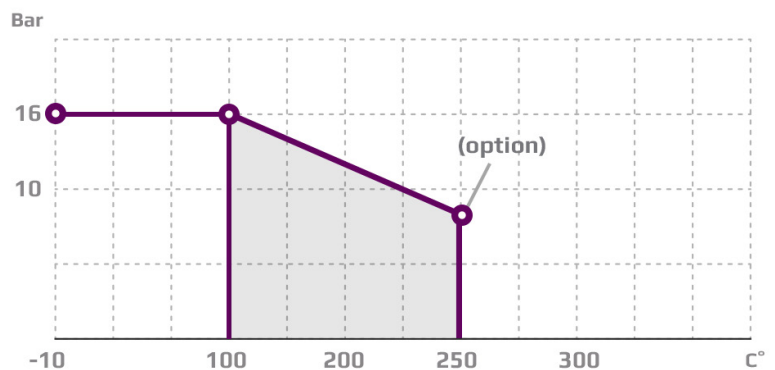

Subject to change without notice.

PORT NUMBERING



MOUNTING

The valve connections are marked A, B and AB. The slide is operating between A and B. Check slide position before installation in the pipe. The slide position is marked on the top of the shaft. The valves can be installed vertically as well as horizontally. The valves must be mounted in a way that the valve actuator will be exposed to a minimum of moisture and unnecessary vibrations.

DIMENSION SKETCH

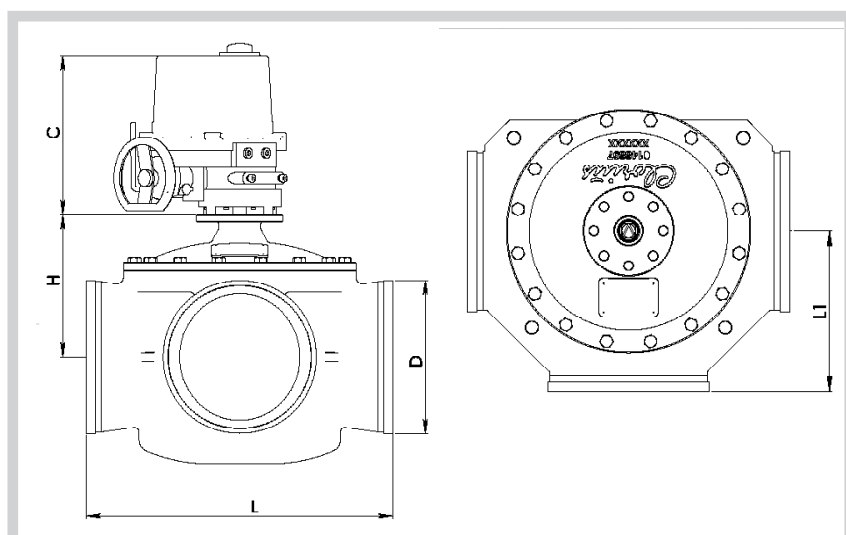

Type	L mm	L1 mm	H mm	B mm	C mm	D (dia.) mm
100	350	175	132	19	470	114
150	480	270	216	24	470	168
200	530	270	236	21	361	219
250	592	300	273	23	361	273
300	649	330	305	25.5	361	324

SPECIFICATIONS

Type	Connection DN in mm	k_{vs} -value ⁽¹⁾ Mixing valve m ³ /h	k_{vs} -value ⁽¹⁾ Diverting valve m ³ /h	Weight kg
100 G3CM ⁽²⁾	100	125	107.5	33
150 G3CM	150	310	266.6	88
200 G3CM-T	200	800	1100	92
250 G3CM-T	250	1500	2100	130
300 G3CM-T	300	2000	2650	170

¹⁾ kvs-value for port A and B 50% open. ²⁾ available from 2015

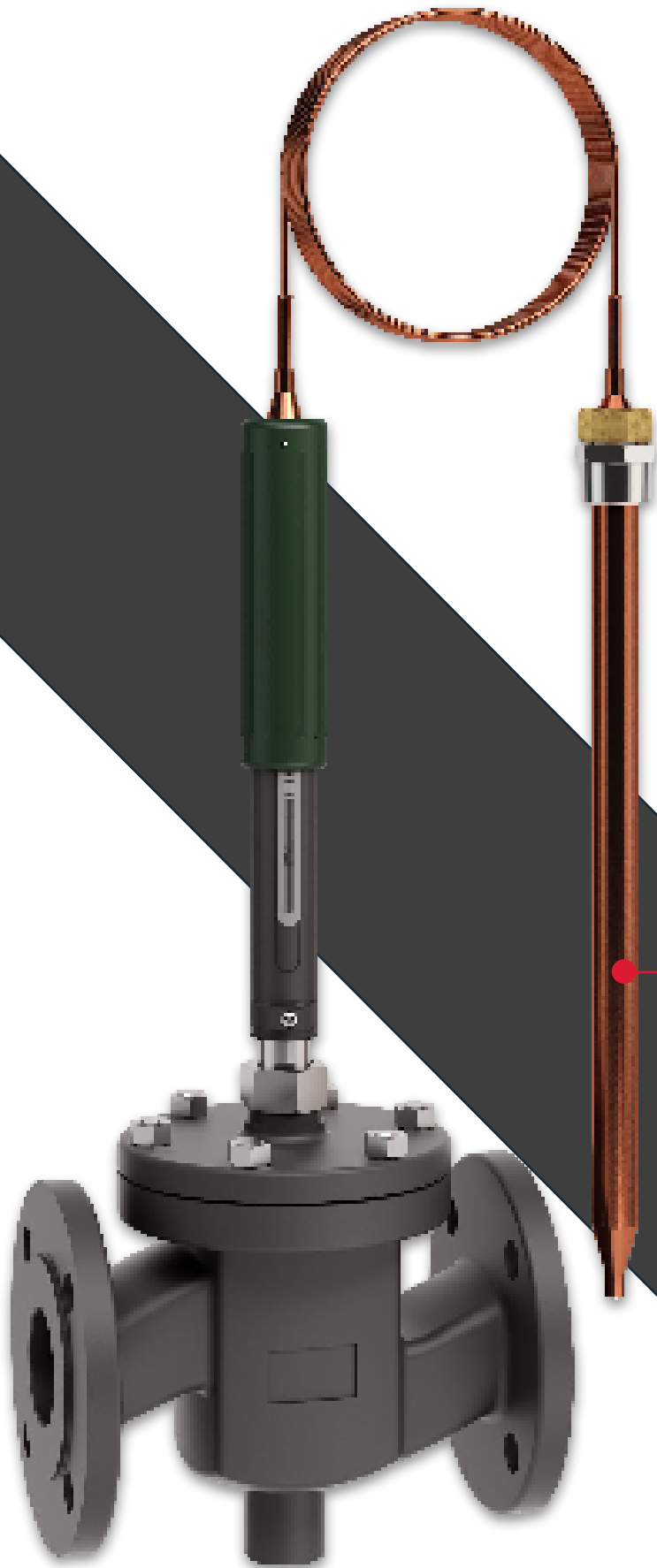

ENSURING CONTINUOUS OPERATION

Self-acting temperature controller will operate in all conditions — without external controls or energy supply, resulting in continuous operation instead of disastrous breakdown.

THERMOSTATS

OUR CONTROL VALVES PROGRAM INCLUDES:

THERMOSTAT TYPES	V2.05	V4.03	V4.05	V4.10	V8.09	V8.18
MAX. CLOSING FORCE	400N	500N	500N	500N	800N	800N
STANDARD SETTING RANGE (°C)	0-60	0-160	0-120	0-60	0-120	0-60
	30-90 60-120		40-160	30-90 60-120	40-160	30-90 60-120

V2, V4 and V8 Thermostats

Self-acting Temperature Controls

0-3.4.01-M

Page 1 of 6



TECHNICAL DATA

Closing force	400 N, 500 N and 800 N
Capillary length	3m to 21m
Neutral zone	1,5°C - 2,5°C
Temperature range	0 to 160°C (-30 to 280°C on request)

For linear valves up to DN150
For heating or cooling valves

APPLICATIONS

The temperature controller, which consists of a thermostat and a valve, is used for controlling the temperature in central heating systems, district heating systems, industrial plants or industrial processes and in marine systems. It can be used for the control of cold or hot water, steam or oil in heating as well as cooling systems.

DESIGN

Thermostat

A thermostat consists of a sensor and a capillary tube, filled with liquid, and an adjusting cylinder. The thermostat type designations and technical data are specified in fig. 2. With temperatures above 170°C, a cooling unit must be fitted between the valve and the thermostat - see fig. 1. The thermostat is self-acting and works on the principle of liquid expansion, it is sturdy in its design, and works with a large closing force - see fig. 2

Sensor

The following sensor types are available - see fig. 4:

- 4.1. Rod sensor in copper or stainless steel and spiral sensor in copper with threaded connection according to ISO R7/1.
- 4.2. Spiral sensor (copper only) with air duct flange.
- 4.3. Rod/spiral sensor with steel flange DN 50, PN 40 and DN 50, PN 160.
- 4.4. Sensor without connection. Usually used with capillary pack box for temperature control in tanks.

Capillary Tube

The capillary tube is made of copper, stainless steel, or of PVC-coated copper - see fig. 3, but can also be delivered with a flexible iron tube protection.

Valve

A wide range of valve types for heating as well as cooling systems can be delivered. For quick and accurate valve selection and valve sizing, we advise you to visit our website www.broenclorius.com or contact us on mail@cloriuscontrols.com.

FEATURES

- No external power required
- For use in hazardous area
- Simple design secures reliable controls and reduces costly downtime
- Customizable, User friendly, Plug & Control
- No special tools needed for service
- Low installation cost

FUNCTION

The adjusting cylinder of the thermostat is set at the required temperature for the heating medium in °C or °F. This setting can be fixed, if required. The temperature control is carried out by the thermostatically controlled valve reducing or increasing the flow of the heating (or cooling) medium. The sensor and the capillary tube, which are filled with a liquid, constitute - together with the adjusting cylinder - a closed system. If the temperature of a medium to be heated is above the required level, the temperature of the sensor liquid rises and expands, causing the piston of the thermostat to act upon the valve, reducing the flow of the heating medium.

Subject to change without notice.

FUNCTION

If the temperature of the medium to be heated is below the required level, the temperature of the sensor liquid falls, reducing the volume of the liquid, so that the piston allows the valve to open under its internal spring, thus increasing the flow of the heating medium. The neutral zone of a thermostat is the temperature difference which can occur at the sensor without any movement of the valve spindle. This represents the sensitivity of the control system to temperature changes: V2 = 2.5°C, V4 = 2°C and V8 = 1.5°C. (see fig. 2.)

CHOICE OF TEMPERATURE CONTROL

The selection of the correct temperature controller is determined by the sizing of the valve and thermostat respectively, which may be chosen by using our web-based software "Quick Choice" available on our website.

Fig. 1 indicates whether the temperature of the heating medium necessitates a cooling unit, and how the thermostat is to be mounted in relation to the valve; for a temperature range -30°C to 170°C the thermostat may be installed both above and below the valve.

Fig. 2 shows the type designation of the thermostat, its closing force in N and its setting range in °C.

Fig. 3 shows the choices of length and material for the capillary tubes.

Fig. 4 shows the different types of sensors.

Fig. 5 shows the time coefficients for the sensors. **Fig. 6** shows the choices of sensor materials, etc.

Fig. 7 shows the dimensions and weights of the sensors as well as the weight of adjusting cylinders and the thermostats.

FIG. 1. TEMPERATURE LIMITS

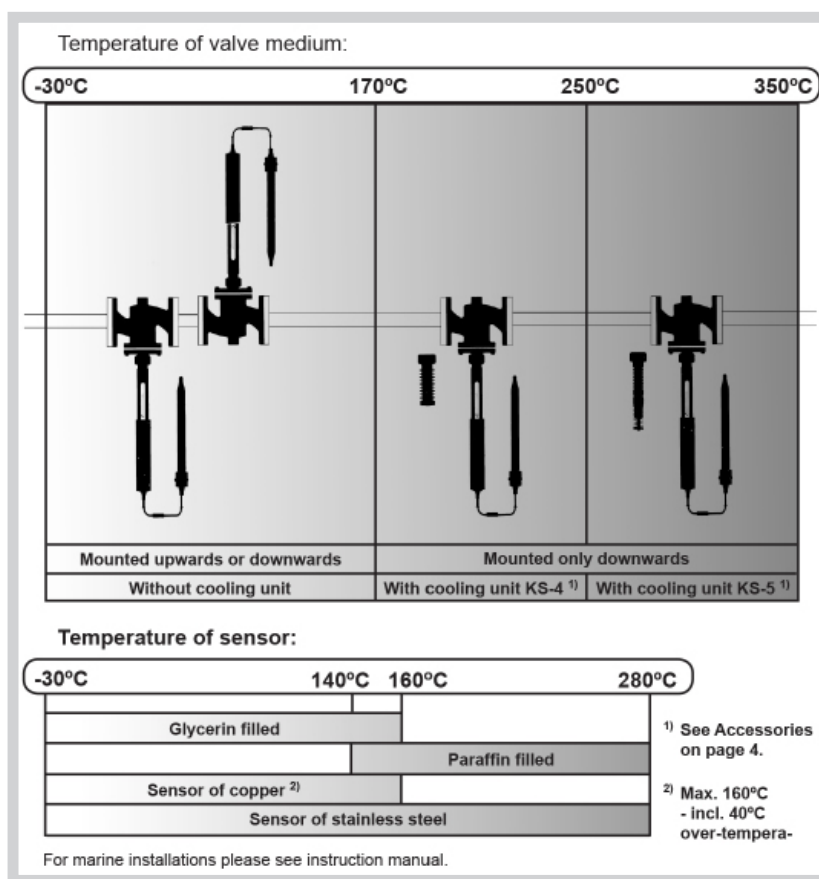

FIG. 2. TEMPERATURE TYPES

Technical Data		Thermostat Types					
		V2.05	V4.03	V4.05	V4.10	V8.09	V8.18
Max. closing force	N	400	500	500	500	800	800
Setting range for standard thermostats ¹⁾	°C	0-60	0-160	0-120	0-60	0-120	0-60
		30-90		40-160	30-90	40-160	30-90
		60-120			60-120		60-120
Neutral zone	°C	2.5	2	2	2	1.5	1.5
For valves with rated travel up to:	mm	10	21	21	21	21	21
Travel (amplification) in range: mm/°C	-30 to 160°C ²⁾	0.5	0.3	0.5	1	0.9	1.8
	140 to 280°C ³⁾	0.7	0.33	0.7	1.33	1.2	2.4

¹⁾ Setting ranges from -30 to 280°C on request. - Excess temp. safety range: 40°C²⁾ Glycerine³⁾ Paraffin

Subject to changes, without notice.

V2, V4 and V8 Thermostats

Self-acting Temperature Controls

0-3.4.01-M

Page 3 of 6

Rod Sensor

Spiral Sensor

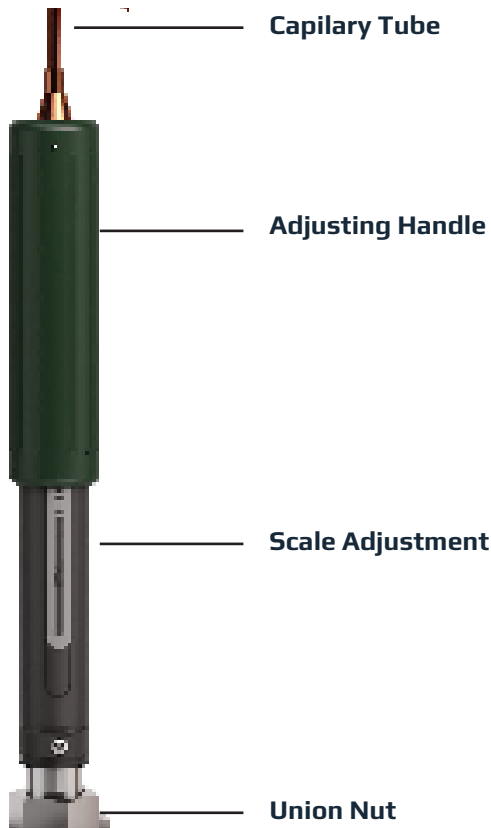

FIG. 3. CAPILLARY TUBES

Choice of capillary tube, length and material, is determined according to the table below, independent of the choice of the thermostat type.

Length	Copper threads	PVC-coated copper	Stainless steel
3 m	✓	✓	✓
6 m	✓	✓	✓
7.5 m			✓
9 m	✓	✓	✓
10.5 m			✓
12 m	✓	✓	✓
13.5 m			✓
15 m	✓	✓	✓
16.5 m			✓
18 m	✓	✓	✓
19.5 m			✓
21 m	✓	✓	✓

FIG. 4. SENSOR TYPES

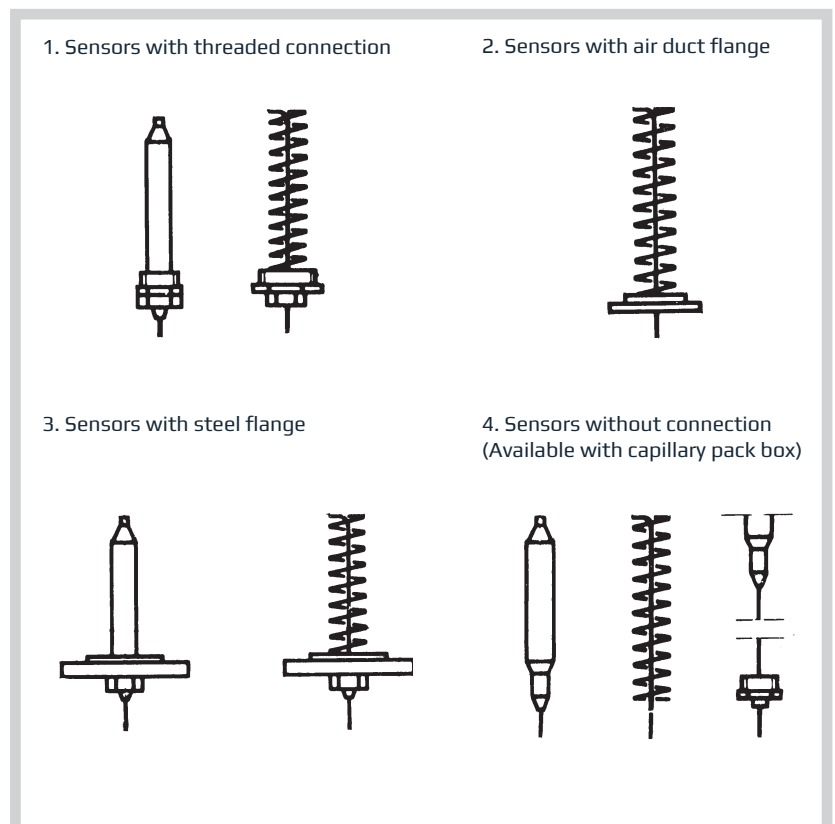
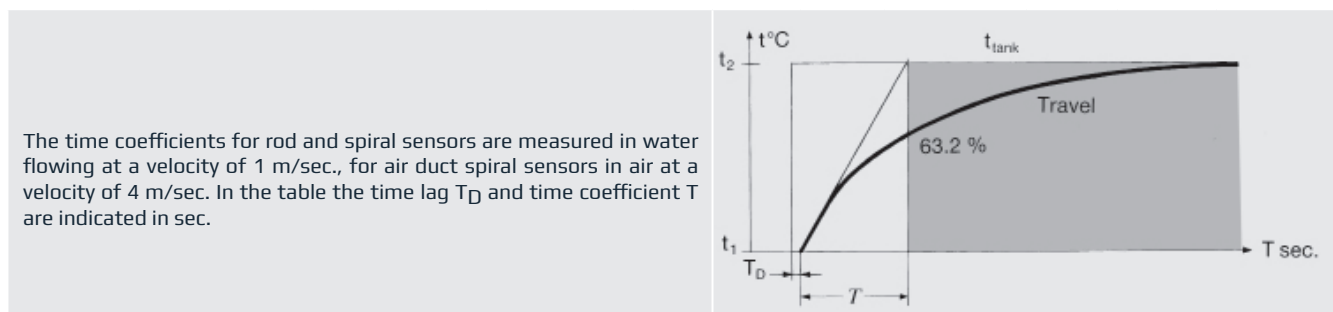

FIG. 5. TIME COEFFICIENT FOR SENSORS



Type	Copper					Acid-resistant stainless steel				Copper with sensor pocket		
	Rod sensor		Spiral sensor		Spiral sensor	Rod sensor		Spiral sensor		Rod sensor		Liquid in sensor pocket
	T_D	T	T_D	T	T	T_D	T	T_D	T	T_D	T	
V2.05	10	85	3	20	360	10	85	3	20	20	210	Hot oil
V4.03	6	120	3	20	360	6	90	3	20	20	250	Hot oil
V4.05	6	130	2	20	360	6	100	2	20	20	200	Hot oil
V4.10	8	165	2	20	360	8	150	2	25	25	300	Hot oil
V8.09	8	165	2	30	600	9	220	2	30	25	450	Hot oil
V8.18						9	280	10	65	28*	570*	Hot oil

FIG. 6. SENSOR MATERIAL ETC.

Adjusting Cylinder	Copper sensors				Acid-resistant				Capillary
									Copper = c Stainless steel = n
DIN/EN no. Material no.	a 10088	b 17440	c 1787	d OM-Metal	e 17100	f 1725	h 17440	k 17440	n 17440

ACCESSORIES

Manual Adjusting Device



With stuffing box. For tightening and manual operation of the valves, when a thermostat has not been fitted, e.g. during periods of construction etc.

Cooling Unit KS-4



Cooling unit protecting the stuffing box of the thermostat. To be applied at valve temperatures between 170°C and 250°C.

Cooling Unit KS-5



Cooling unit with built-in bellows gland. Replaces the stuffing box of thermostat. Must be applied by valve temperatures between 250°C and 350°C.



V2, V4 and V8 Thermostats

Self-acting Temperature Controls

0-3.4.01-M

Page 5 of 6

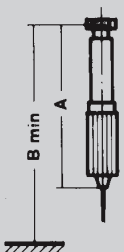
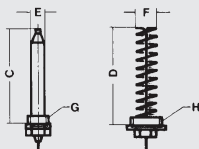
FIG. 7. DIMENSIONS AND WEIGHTS

The measurements G and H are pipe threads according to ISO R7/1. All other measurements are mm. Weight: Net. c = Copper sensor. s = Acid-resistant stainless steel sensor.		Thermostat / Sensor material												
		Type V2.05		Type V4.03		Type V4.05		Type V4.10		Type V8.09		Type V8.18		
		c	s	c	s	c	s	c	s	c	s	c	s	
Adjusting cylinder  Weights see below	A	305	305	385	385	385	385	385	385	560	560		560	
	B	405	406	525	525	525	525	525	525	740	740		740	
Sensor with threaded connection  Weight incl. G-connection Weight incl. H-connection	C	210	190	210	190	390	380	490	515	710	745		800	
	D	235	170	235	170	235	250	325	325	425	435		810	
	E	22	22	22	22	22	22	28	25	28	25		34	
	F	49	49	49	49	49	49	49	49	49	49		49	
	G	R $\frac{3}{4}$	R $\frac{3}{4}$	R1	R1	R1	R1	R1	R1	R1	R2	R2		R2
	H	R2	R2	R2	R2	R2	R2	R2	R2	R2	R2	R2		R2
	kg	1.8	1.8	2.4	2.4	2.6	2.6	3.3	3.3	6.3	6.3		7.3	
	2.3	2.3	2.9	2.9	3.1	3.1	3.8	3.8	6.3	6.3		7.3		
Sensors with air duct flange 	F	49		49		49		49		49				
	I	430		430		430		430		450				
	L	60		60		60		60		60				
	M	95		95		95		95		95				
	kg	1.8		2.4		2.6		3.3		5.8				

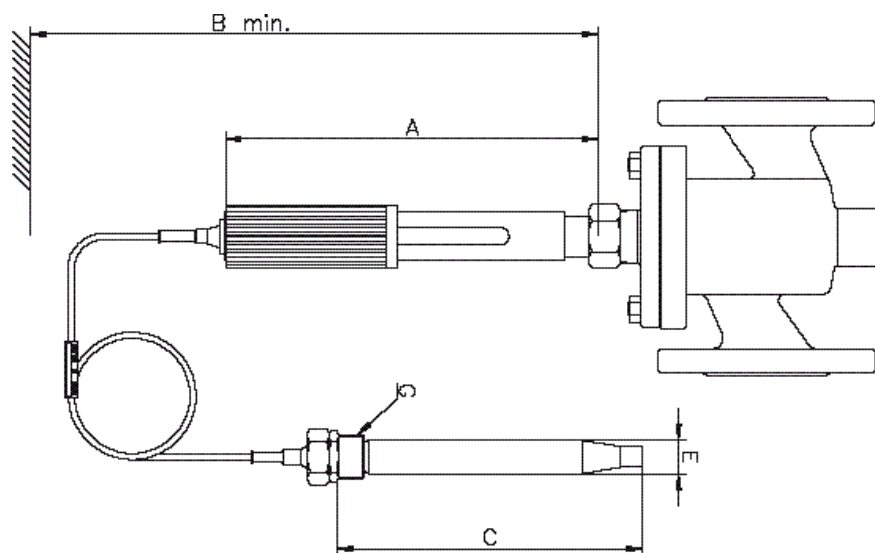
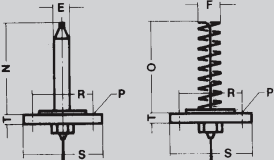
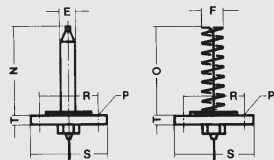
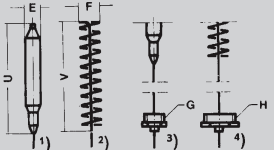

FIG. 7. DIMENSIONS AND WEIGHTS

The measurements G and H are pipe threads according to ISO R7/1. All other measurements are mm. Weight: Net. c = Copper sensor. s = Acid-resistant stainless steel sensor.		Thermostat / Sensor material												
		Type V2.05		Type V4.03		Type V4.05		Type V4.10		Type V8.09		Type V8.18		
		c	s	c	s	c	s	c	s	c	s	c	s	
Sensor with steel flange DN 50, PN 40 	E	22	22	22	22	22	22	28	25	28	25		34	
	F	49	49	49	49	49	49	49	49	49	49		49	
	N	200	180	200	180	380	360	480	505	700	735		790	
	O	225	160	225	160	225	240	315	315	415	425		800	
	P	4x18	4x18	4x18	4x18	4x18	4x18	4x18	4x18	4x18	4x18		4x18	
	R	125	125	125	125	125	125	125	125	125	125		125	
	S	165	165	165	165	165	165	165	165	165	165		165	
	T	22	22	22	22	22	22	22	22	22	22		22	
	kg	5.3	5.3	5.9	5.9	6.1	6.1	6.8	6.8	9.3	9.3		10.3	
	Sensor with steel flange DN 50, PN 160 	E	22	22	22	22	22	22	28	25	28	25		34
F		49	49	49	49	49	49	49	49	49	49		49	
N		180	160	180	160	360	340	460	485	680	715		770	
O		205	140	205	140	205	220	295	295	395	405		780	
P		4x27	4x27	4x27	4x27	4x27	4x27	4x27	4x27	4x27	4x27		4x27	
R		145	145	145	145	145	145	145	145	145	145		145	
S		195	195	195	195	195	195	195	195	195	195		195	
T		45	45	45	45	45	45	45	45	45	45		45	
kg		11.3	11.3	11.9	11.9	12.1	12.1	12.8	12.8	15.3	15.3		16.3	
Sensors without connection Available with capillary pack box in stainless steel (1.4436) 		E	22	22	22	22	22	22	28	25	28	25		34
	F	49	49	49	49	49	49	49	49	49	49		49	
	G	R1	R1	R1	R1	R1	R1	R1	R1	R1	R2	R2		R2
	H	R2	R2	R2	R2	R2	R2	R2	R2	R2	R2	R2		R2
	U	250	230	250	230	430	410	535	555	750	785		840	
	V	290	220	290	220	290	310	375	370	470	490		860	
	kg¹⁾	1.6	1.6	2.2	2.2	2.3	2.3	3	3	5.5	5.5		6.5	
	kg²⁾	1.6	1.6	2.2	2.2	2.4	2.4	3.1	3.1	5.6	5.6		6.6	
	kg³⁾	1.8	1.8	2.4	2.4	2.6	2.6	3.3	3.3	6.3	6.3		7.3	
	kg⁴⁾	2.3	2.3	2.9	2.9	3.1	3.1	3.8	3.8	6.3	6.3		7.3	



Thermostats of stainless steel types V4.03 and V4.05

0-3.4.05-F

Page 1 of 2

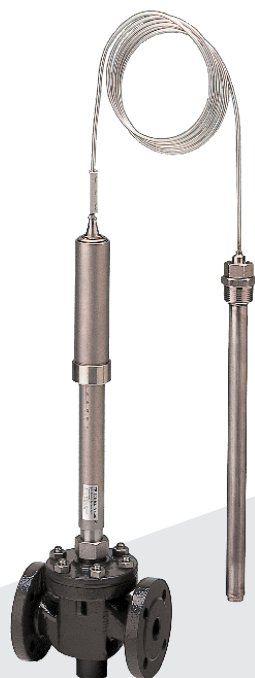

TECHNICAL DATA

Max. closing force	500 N
Standard settings:	
- Type V4.03	0-160 °C
- Type V4.05	0-120, 40-160 °C
Reinforcement (mm/°C):	
- Glycerine	Type V4.03: 0.3 Type V4.05: 0.5
- Paraffin	Type V4.03: 0.33 Type V4.05: 0.7
For valves with lifting height up to	21 mm
Time constant for rod sensor:	
- Type V4.03:	90 sec.
- Type V4.05:	100 sec.
Time constant for spiral sensor,	20 sec.
Neutral zone	< 2°C
Excess temperature protection	40°C
Materials:	
- Spring:	1.4401
- Capillary:	1.4301
- Adjusting cylinder:	1.4501

Sensor material W. No. 1.4436

Subject to change without notice.

APPLICATIONS

The thermostat is particularly suitable for installation in demanding environments such as tank installations, outdoor plants and where it must be non-magnetic, e.g. in submarines.

FUNCTION

The adjusting cylinder of the thermostat is set at the temperature in °C for the required heated medium. The temperature is regulated by the thermostatically controlled valve reducing or increasing the flow of the heating medium. Together with the adjusting cylinder, the liquid-filled sensor and capillary tube constitute a closed system. If the temperature of the medium to be heated is above the required level, the sensor liquid expands, causing the spindle of the thermostat to act upon the valve, thereby reducing the flow of the heating medium. If the temperature is below the required level, the temperature of the liquid in the sensor decreases and the volume is reduced, thereby the valve spring opens the valve causing an increasing flow of the heating medium.

CONSTRUCTION

The parts of the thermostat are made of stainless steel. The thermostat consists of a liquid-filled sensor, a capillary tube, and an adjusting cylinder. The adjusting cylinder has O-ring sealings and is sealed with silicone glue at the top for hermetical closure. The thermostat is available with settings between -30°C and +280°C. At flow temperatures above 170°C, a cooling unit must be installed between the valve and the thermostat. Please see datasheet no. 8.5.00.

FEATURES

- No external power required
- For use in hazardous area
- Simple design secures reliable controls and reduces costly downtime
- Customizable, User friendly, Plug & Control
- No special tools needed for service
- Low installation cost
- For outdoor installation even on open ship deck
- Self-acting
- P-controller
- Completely sealed
- Excess temperature protection
- All parts made of stainless steel
- Non-magnetic

NEUTRAL ZONE

The neutral zone of the thermostat, which is less than 2 °C, is the temperature difference which can occur at the sensor without the thermostat spindle being actuated.

SENSOR TYPES

Rod sensors of stainless steel with pipe thread. Sensors are also available with a pack-box on the capillary tube for applications where the sensor is to be lowered into a tank etc.

SENSOR LIQUID

Glycerine at a scale range between - 30 °C and 160 °C. Paraffin at a scale range between 140 °C and 280 °C.

CAPILLARY TUBE

The capillary tube is made of stainless steel and is available in lengths from 3 m up to 21 m.

VALVES

The thermostat may be used for valves up to DN 150 mm for heating and cooling plants. For quick and accurate valve selection and valve sizing, we advise you to visit our website www.broenclorius.com and select our sizing software Quick Choice 4.



Sensors with pipe thread	Type V4.03	Type V4.05
	C E G* 190 mm 22 mm 1"	380 mm 22 mm 1"
Weight including G connection	2.4 kg	2.6 kg

Sensors without connection Available with capillary packbox	Type V4.03	Type V4.05
1) 3)	E U G* 22 mm 230 mm 1"	22 mm 410 mm 1"
Weight	1) 2.2 kg 2) 2.4 kg	2.3 kg 2.6 kg

* The measurements G and H are pipe threads according to ISO R7/1.

DIMENSION SKETCH

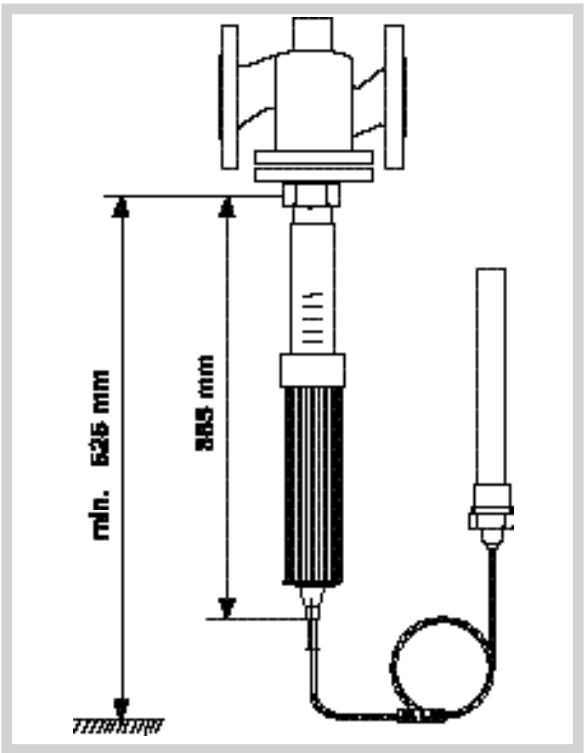

Duostats

Self-acting Temperature Controls

0-3.5.01-G

Page 1 of 4

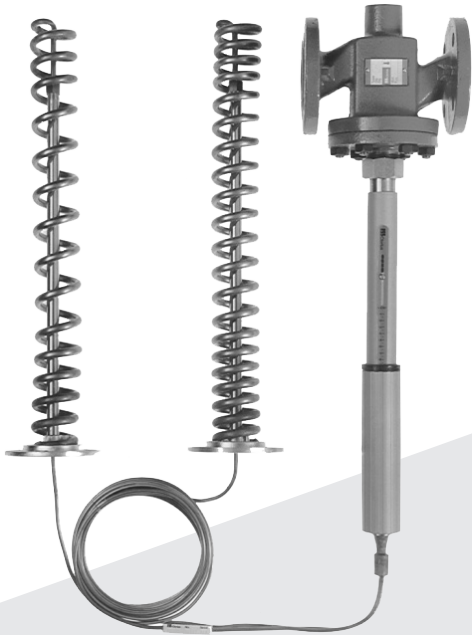

TECHNICAL DATA

Closing force	500 N
Capillary length	3m to 21m
Neutral zone	1,5°C - 2,5°C
Temperature range	0 to 160°C (-30 to 280°C on request)

For linear valves up to DN150
For heating or cooling valves

CLORIUS DUOSTATS

Duostats are thermostats, type V, which via two sensing elements in a common hydraulic system act on one and the same control valve.

Two basic types are available: V4.05 or V4.10, depending on the preferable proportional band PB, and the valve size.

The sensing elements are two spiral sensors for the ventilation duct or two rod sensors (a combination of one spiral sensor and one rod sensor may be supplied in certain combinations). The effect, which the two sensing elements have on the adjustment, is proportional to the liquid volume of the individual sensors. Duostats are therefore available with varying proportions between the liquid volumes of the two sensors (sensor proportions) and in that way they can meet the requirements made by a number of different adjustment problems. As the adjustment result is a weighted average value of the temperatures of the two sensors, no fixed adjustment value can be indicated. Hence, Duostats are not equipped with a temperature scale, but with a marking for adjustment towards higher or lower temperatures, respectively.

SELECTION OF DUOSTAT TYPES

For quick and accurate valve selection and valve sizing, we advise you to visit our website www.broenclorius.com or write to us at mail@cloriuscontrols.com.

APPLICATIONS

1. Adjustment of discharge air temperatures in hot-air heating plants, dependent on the outdoor temperature.
2. Adjustment of two temperatures which are interdependent. E.g. the hot-water tank of a district heating plant with simultaneous control that the return water temperature does not become too high.

FEATURES

- No external power required
- For use in hazardous area
- Simple design secures reliable controls and reduces costly downtime
- Customizable, User friendly, Plug & Control
- No special tools needed for service
- Low installation cost

Subject to change without notice.

APPLICATIONS

Air Heating Plants

For air heating plants Duostats with two spiral sensing elements for air ducts are used. **Fig. 1** shows an example of a plant with Duostat. The primary sensor V_p (red) is the real control sensor which goes into the controlled system. The secondary sensor V_s (blue) which is located outside the controlled system, registers the outdoor temperature and determines the necessary air temperature by V_p . If there is no supply air duct, where the secondary sensor can be built in, it can be placed in free air. For this purpose a wall bracket is available. In order to determine the correct Duostat, use diagram A where the combinations of spiral sensors for air ducts are found on the left hand.

Other Applications

Duostats are sometimes used for purposes where both sensing elements go into the same controlled system (see examples 2 and 3). The controlled condition will then be a weighted average of the registrations of the two sensors, as shown in the following examples.

In **fig. 2** a hot-water tank connected to district heating is adjusted by a Duostat whose one sensor - the primary sensor - controls the temperature of the tank which should be constant. The secondary sensor registers the temperature of the water which is led back to the district heating network. It secures that the valve does not open so much that the temperature of the return water rises in an uncontrolled manner, when a large water consumption reduces the temperature in the tank.

Fig. 3 shows a room heated by hot air. The primary sensor is built into the extract air duct in order to serve as a room thermostat from this place. The secondary sensor is built into the discharge air duct where it counteracts that the discharge air temperature becomes too low - which would feel like a draught - when the room temperature rises as a result of the heat development which may come from persons or heating processes in the room.

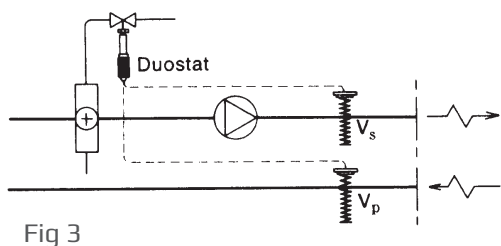
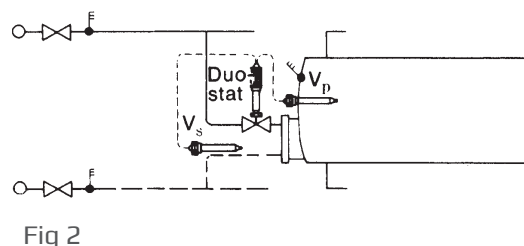
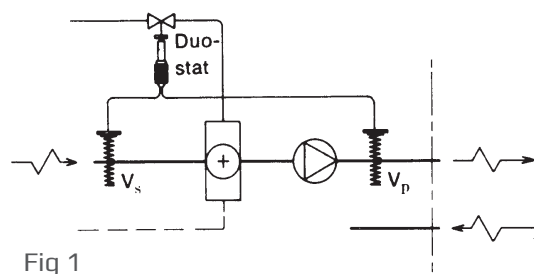

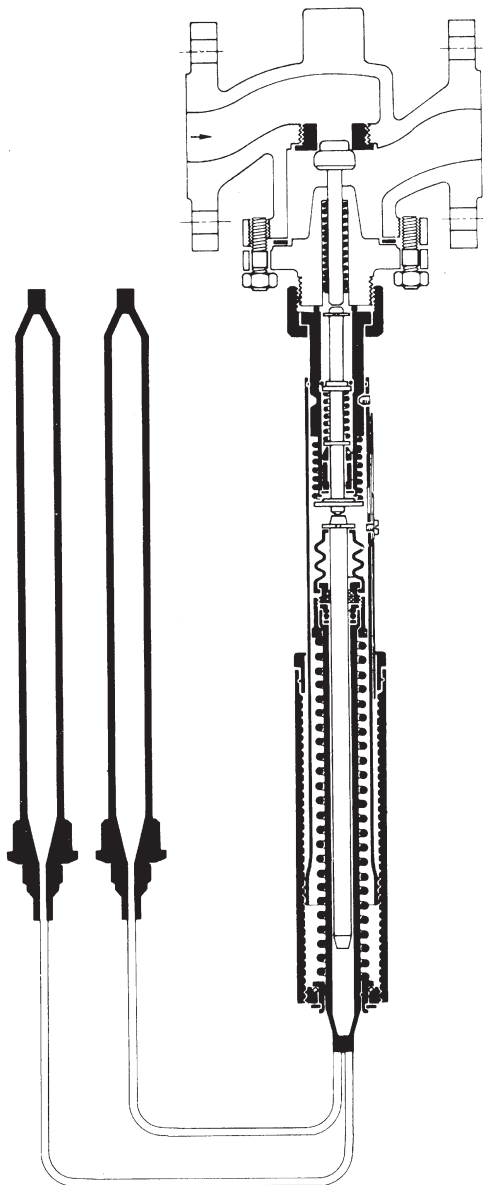

THEORETICAL BASIS

The theoretical basis for the use of Duostats for room heating plants rests on the balance between the heat brought to the plant, and the thermal loss from the heated rooms to the surroundings. By hot-air plants (**fig. 1**) this may approximately be expressed by equation 1), but with small changes, these considerations may be applied to central heating plants with water as the heat carrier.

$$1) Lc_p (t_i - t_u) = \Sigma kf(t_r - t_u)$$

Here L is the quantity of air which is heated from the outdoor temperature t_u to the discharge temperature t_i , and c_p is the specific heat of the air. $k \cdot f$ expresses the sum of transmission surfaces, joints, etc., through which heat is lost to the surroundings by the difference between the temperatures of the heated rooms t_r and the outdoor temperature t_u . As L, c_p , $k \cdot f$ and the room temperature are constant sizes, equation 1) can be converted into:

$$2) (t_{i \max} - t_{i \min}) / (t_{u \max} - t_{u \min}) = \Delta t_i / \Delta t_u = n$$

Here $t_{i \max}$ and $t_{u \min}$ are belonging values for the calculated discharge air temperature by the outdoor temperature for which the plant has been dimensioned. In the same way, $t_{i \min}$ and $t_{u \max}$ are interbelonging values by the condition where the thermal loss is 0 (normally 20°C). The size n expresses how many degrees t_i has to be raised, when t_u falls one degree. It is constant for the individual plant, but varies from plant to plant. This problem can be met by supplying the Duostats with different sensor proportions. The proportion between the liquid volume in secondary and primary sensors is:

$$3) V_s / V_p = 1.25n$$

This formula is approximate, as the expansion coefficient of the liquid (glycerine) varies with the temperature, which is compensated for with the factor 1.25.

ORDER DIAGRAM

By specifications of Duostats, the following information is given:

1. Valve. Dimension and type	Example 15 M1F
2. Duostat. Basic type and sensor proportion	V4.05 C
3. Capillary tube from adjusting cylinder to secondary sensor (Vs, blue)	6 m
4. Capillary tube from adjusting cylinder to primary sensor (Vp, red)	3 m

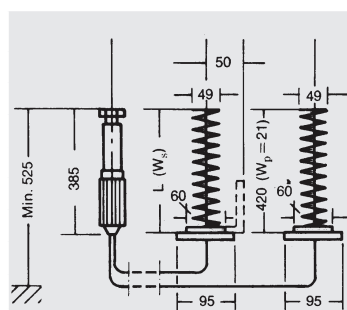

Type		V4.05 A	V4.05 B	V4.05 C	V4.05 D	V4.05 E
Closing power	N	500	500	500	500	500
Length of secondary sensor L	mm	430	430	430	430	430
Secondary sensor's windings W_s		7	10	14	21	29
Secondary sensor's time constant *	sec.	360	360	360	360	360
Primary sensors's time constant *	sec.	360	360	360	360	360
Sensor proportion $V_s : V_p$		0.35:1	0.5:1	0.7:1	1:1	1.4:1
Excess temperature protector	°C	80	80	80	80	80
Max. lifting height	mm	21	21	21	21	21
Travel	mm/°C	0.5	0.5	0.5	0.5	0.5

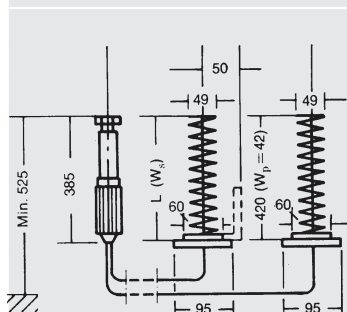

Type		V4.10 A	V4.05 B	V4.05 C	V4.05 D	V4.05 E
Closing power	N	500	500	500	500	500
Length of secondary sensor L	mm	430	430	430	430	430
Secondary sensor's windings W_s		14	21	29	42	42
Secondary sensor's time constant *	sec.	360	360	360	360	360
Primary sensors's time constant *	sec.	360	360	360	360	360
Sensor proportion $V_s : V_p$		0.35:1	0.5:1	0.7:1	1:1	1.45:1
Excess temperature protector	°C	40	40	40	40	40
Max. lifting height	mm	21	21	21	21	21
Travel	mm/°C	1	1.0	1.0	1.0	1.0

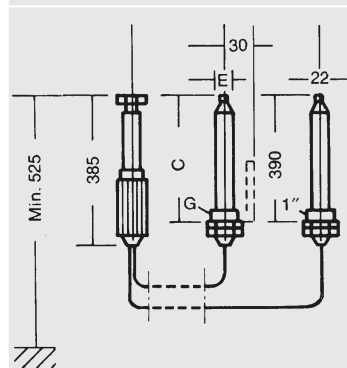

Type		V4.05 L	V4.05 M
Closing power	N	500	500
Length of secondary sensor C	mm	390	490
Secondary sensor's diam. E	mm	22	28
Secondary sensor's thread conn. G	ISO 7/1	R1	R1
Secondary sensor's time constant*	sec.	130	165
Primary sensor's time constant	sec.	130	130
Sensor proportion $V_s : V_p$		1:1	2:01
Excess temperature protector	°C	0:00	80
Max. lifting height	mm	21	21
Travel	mm/°C	0.5	0.5

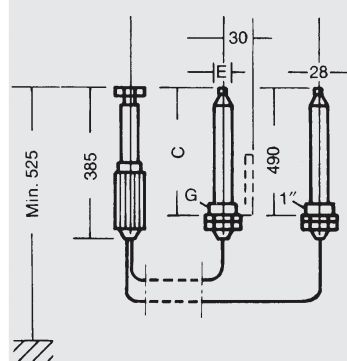

Type		V4.10 L	V4.10 N
Closing power	N	500	500
Length of secondary sensor C	mm	490	800
Secondary sensor's diam. E	mm	28	34
Secondary sensor's thread conn. G	ISO 7/2	R1	R2
Secondary sensor's time constant*	sec.	165	280
Primary sensor's time constant	sec.	165	165
Sensor proportion $V_s : V_p$		1:1	2.9:1
Excess temperature protector	°C	0:00	40
Max. lifting height	mm	21	21
Travel	mm/°C	1	1.0

*The time constants are for spiral sensing elements for air ducts measured in air with a velocity of 4 m/sec. For rod sensing elements they are measured in water with a velocity of 1 m/sec.



**HIGH PRECISION
& REPEATABILITY**

Our Electric actuators are compact and powerful actuator systems, which provide a long service life. Designed for our range of both linear and rotary valves



ELECTRIC ACTUATORS

OUR ELECTRIC ACTUATOR PROGRAM INCLUDES:

ACTUATOR TYPE

ROTARY ELECTRIC

LINEAR ELECTRIC

LINEAR WITH FAIL SAFE FUNCTION

ACTUATOR MODEL

CAR-H 006 - S400

AVM321, AVM322, AVM234

AVF234

ELECTRIC VALVE ACTUATOR TYPE CAR-H

FOR 2 & 3-WAY VALVES TYPE G/L/M/S 2FM-T & G/L/S/T AND TM

O-4.11.09-E

Page 1 of 8



TECHNICAL DATA

Protection class: IP67/IP68 option

Ambient temperature: -20°C to +60°C

Power supply:

110/230 VAC + -10% (50-60Hz)

24VDC: CAR-H 006-0250 - ON/OFF

24VDC: CAR-H 006-035 - PCU or CPT

Torque switches: Open/Close

Limit switches: 2x Open/Close

Stall protection: Built-in thermal protection
Cut-off at 125°C ± 5°C /
reset at 90°C ± 15°C

Travel angle: 90°±5°

Indicator: Continuous position indicator
Manual override: AUTO declutching mechanism
Worm gear: Permanently lubricated and self-locking

Mechanical stops: External adjustable limit stops

Space heater: 2 or 5W
Anti-condensation

Cable glands: 2 x M20 x 1,5mm

Lubrication: Grease NLGI grade 2 (EP-type)

Materials: Steel, aluminium alloy, Al-bronze
External coating: anodizing and dry powder epoxy painted RAL 6018 (green)

Duty cycle: ON/OFF AC230V, S2: 10min

Modulating: S4-25% ~ 600 start/hour

Anti-vibration: XYZ 10g 02 ~ 34Hz, 30min

Overvoltage: CAT. III

Available actuator size

STANDARD: On-Off, 3-Point

Modulating/PCU

Command signal input: 4-20mA or 0-10V

Analogue feedback signal: 4-20mA or 0-10V self powered

Deep band: 1,0% adjustable

CPT: feedback signal 4-20mA

APPLICATIONS

Electric valve actuator type CAR-H is specially designed to meet the demands of the powerful low frequency vibration environments in marine installations.

The main applications are cooling of fresh water, sea water and lubricating oil systems for main and auxiliary engines. The actuator is used for Clorius 2 or 3-way valves type L3FM-T, M3FM-T, G3FM-T and S3FM-T, H3FM-T and type TM with double slides.

MOUNTING

For mounting and starting up, the instructions delivered with the actuator must be followed carefully.

SERVICE

No special service is needed. It is recommended to check and grease the actuator at every docking or every three years.

FEATURE

- Robust design
- Maintenance free
- Reliable even in rough environments
- Easy installation
- User friendly

SPECIFICATIONS

Type	Max. torque Nm	Operating time sek/90° (50/60 Hz)	RATED CURRENT (A) 230 V AC	RATED CURRENT (A) 110 V AC	RATED CURRENT (A) 24 V AC/DC	Power (W)	Duty cycle S2 (min) ON-OFF	Duty cycle S4 (%)	Weight (kg)
CAR-H 006	60	26/22	0,45	-	-	20	10	25	8
CAR-H 010	100	26/22	0,5	1,0	1,7	20	10	25	8
CAR-H 016	160	28/23	0,6	1,45	2,0	40	10	25	14
CAR-H 020	200	28/23	0,6	1,5	2,2	40	10	25	14
CAR-H 024	240	28/23	0,7	1,6	2,8	45	10	25	14
CAR-H 035	350	32/27	0,9	1,8	4,0	60	10	25	18
CAR-H 050	500	32/27	1,3	3,2	6,9	90	10	25	19
CAR-H 080	800	36/30	1,5	3,9	9,8	120	10	25	24
CAR-H 110	1100	36/30	2,2	4,2	12,5	180	10	25	26
CAR-H S200	2000	55/46	2,2	4,2	12,5	180	10	25	46
CAR-H S250	2500	110/92	2,2	4,2	12,5	180	10	25	46
CAR-H S400	4000	150/125	2,2	4,2	12,5	180	10	25	61

DIMENSION SKETCH

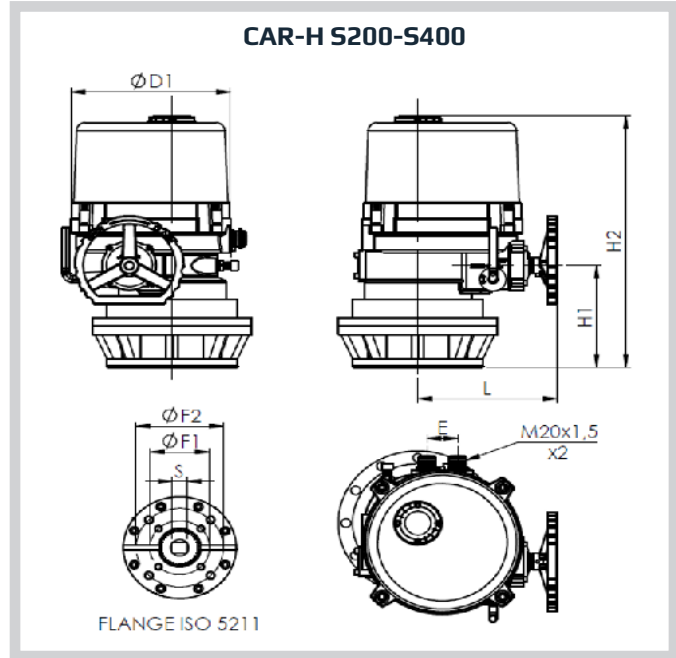
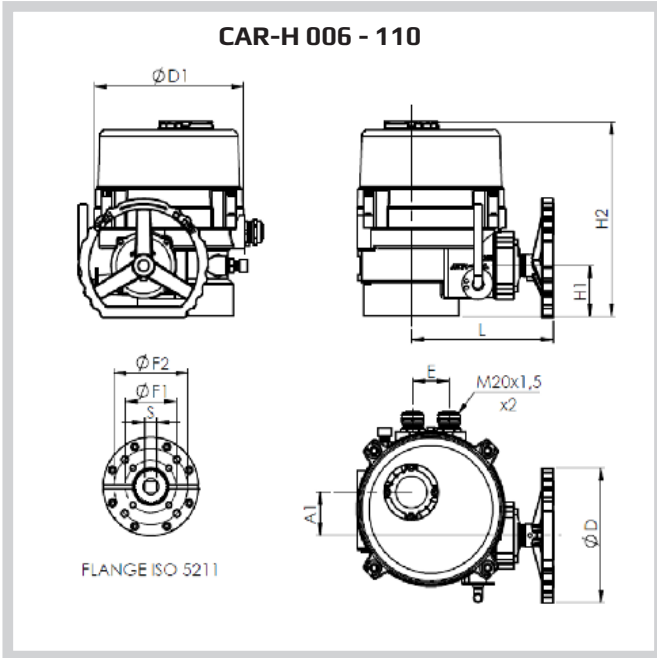

3

Type	A1	ØD	ØD1	H1	H2	L	E	ISO FLANGE 5211				
								F1	F2	M1	M2	S
								Ø	Ø			SQUARE
CAR-H 006	41	100	157	55	223	167	46	70	82	M8	M8	12x12 - 17x17
CAR-H 010	41	100	157	55	223	167	46	70	82	M8	M8	12x12
CAR-H 016	57,5	180	206	67	261	197	50	82	102	M8	M10	17x17
CAR-H 020	57,5	180	206	67	261	197	50	82	102	M8	M10	17x17
CAR-H 024	57,5	180	206	67	261	197	50	70	102	M8	M10	19x19
CAR-H 035	60,5	180	222	70	315	208	50	102	125	M8	M10	19x19
CAR-H 050	60,5	180	222	70	315	208	50	102	125	M8	M10	27x27
CAR-H 080	70	180	262	81	352	230	50	125	140	M12	M16	27x27
CAR-H 110	70	180	262	81	352	230	50	125	140	M12	M16	27x27
CAR-H S200	70	180	262	185	456	230	50	140	165	M16	M20	27x27 - 46x46
CAR-H S250	70	180	262	185	456	230	50	140	165	M16	M20	46x46
CAR-H S400	70	180	262	303	574	/	50	165	254	M16	M20	52x52

RECOMMENDED CAR MOUNTING POSITION

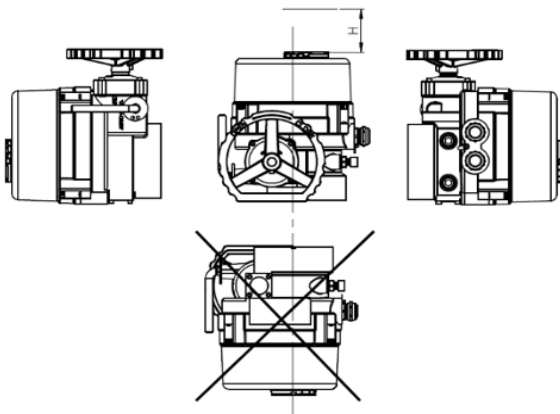

Actuator type	H
CAR-H 006 - 110	150
CAR-H S200-S400	200

ELECTRIC VALVE ACTUATOR TYPE CAR-H

For 2 & 3-way valves type G/L/M/S 2FM-T & G/L/M/S 3FM-T

O-4.11.09-E

110/230 VAC

Wiring diagram ON/OFF- for CAR-H 006-010

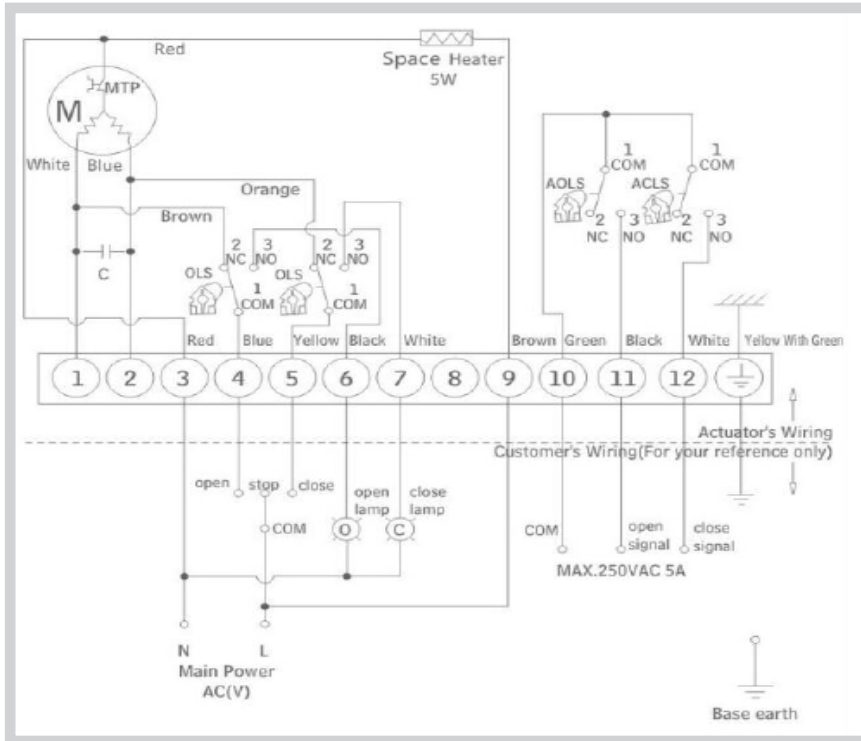

AOLS:	AUX. Open limit switch (250VAC 5A)
ACLS:	AUX. Close limit switch (250VAC 5A)
O:	Open lamp
C:	Close lamp
CLS:	Close limit switch
OLS:	Open limit switch
KMC:	Magnetic contactor close
KMO:	Magnetic contactor open
MTP:	Motor thermal protector
M:	Motor

Switch	Full Close ←	Intermediate	→ Full Open
CLS 1-2	[Bar chart showing signal presence]		
CLS 1-3	[Bar chart showing signal presence]		
OLS 1-2	[Bar chart showing signal presence]		
OLS 1-3	[Bar chart showing signal presence]		
ACLS 1-3	[Bar chart showing signal presence]		
AOLS 1-3	[Bar chart showing signal presence]		

110/230 VAC

Wiring diagram ON/OFF for CAR-H 016-S400

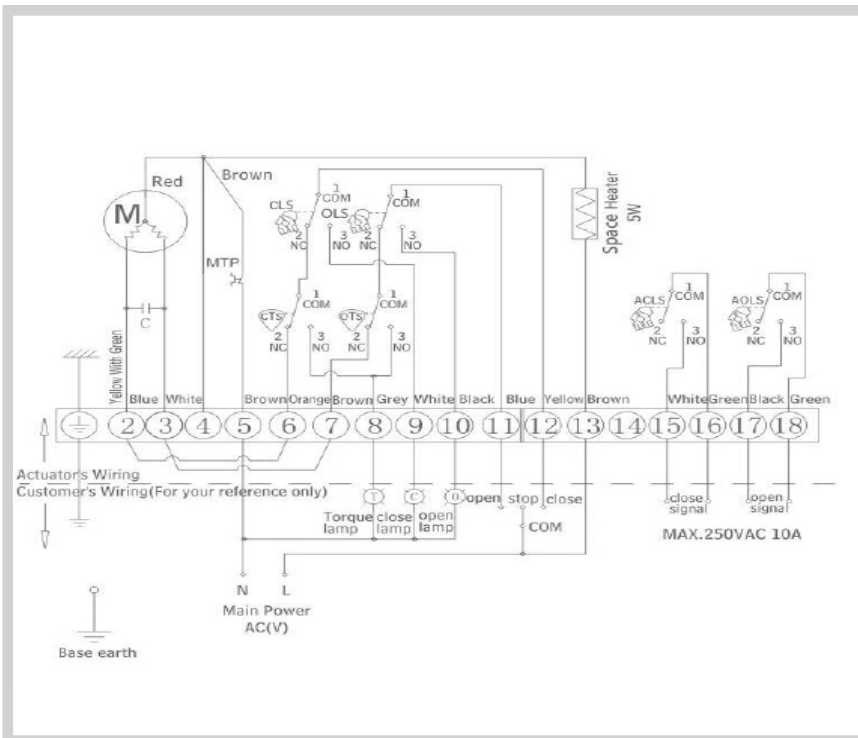

AOLS:	AUX. Open limit switch (250VAC 10A)
ACLS:	AUX. Close limit switch (250VAC 10A)
O:	Open lamp
C:	Close lamp
T:	Torque switch
CLS:	Close limit switch
OLS:	Open limit switch
CTS:	Close torque switch
OTS:	Open torque switch
RP1:	Potentiometer 1KΩ
KMC:	Magnetic contactor close
KMO:	Magnetic contractor open
MTP:	Motor thermal protector
M:	Motor

Switch	Full Close ←	Intermediate	→ Full Open
CLS 1-2	[Bar chart showing signal presence]		
CLS 1-3	[Bar chart showing signal presence]		
OLS 1-2	[Bar chart showing signal presence]		
OLS 1-3	[Bar chart showing signal presence]		
ACLS 1-3	[Bar chart showing signal presence]		
ACLS 1-2	[Bar chart showing signal presence]		
AOLS 1-3	[Bar chart showing signal presence]		

CTS 1-3	Closing torque switch interrupts control when mechanical overload occurs during closing cycle
OTS 1-3	Opening torque switch interrupts control when mechanical overload occurs during opening cycle

110/230 VAC
Wiring diagram MODULATING/PCU for CAR-H 006-010

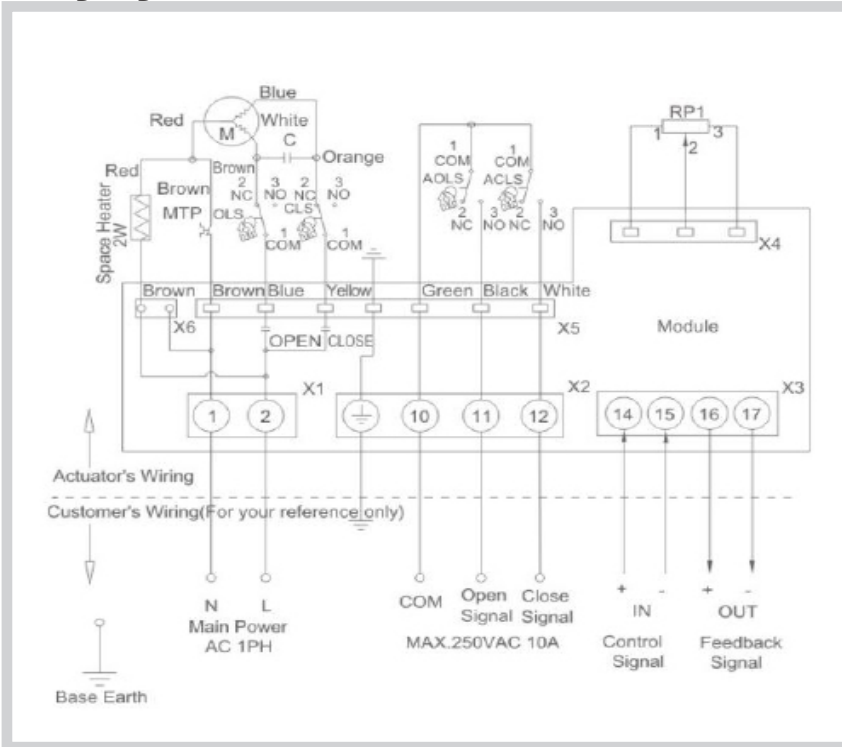

AOLS:	AUX. Open limit switch (250VAC 10A)
ACLS:	AUX. Close limit switch (250VAC 10A)
O:	Open lamp
C:	Close lamp
T:	Torque switch
CLS:	Close limit
OLS:	Open limit switch
RP1:	Potentiometer 1KΩ
KMC:	Magnetic contactor close
KMO:	Magnetic contactor open
MTP:	Motor thermal protector
M:	Motor

Switch	Full Close	Intermediate	Full Open
CLS 1-2	█	█	█
CLS 1-3	█	█	█
OLS 1-2	█	█	█
OLS 1-3	█	█	█
ACLS 1-3	█	█	█
AOLS 1-3	█	█	█

3

110/230 VAC
Wiring diagram Modulating/PCU for CAR-H 016-5400

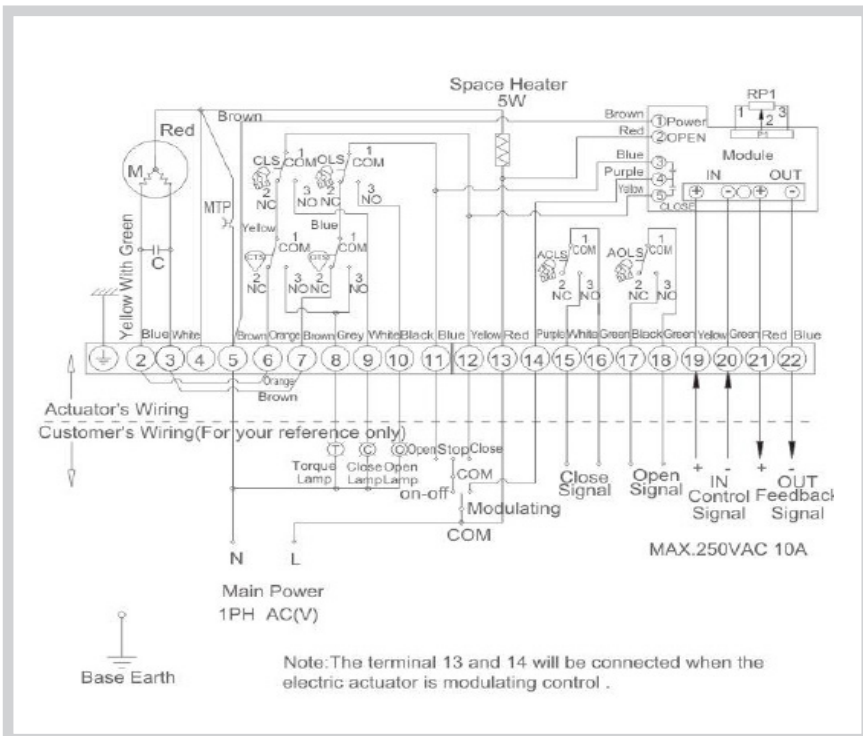

AOLS:	AUX. Open limit switch (250VAC 10A)
ACLS:	AUX. Close limit switch (250VAC 10A)
O:	Open lamp
C:	Close lamp
T:	Torquo switch
CLS:	Close limit switch
OLS:	Open limit switch
CTS:	Close torque switch
OTS:	Open torque switch
RP1:	Potentionmeter 1KΩ
KMC:	Mangetic contactor close
KMO:	Magnetic contactor open
MTP:	Motor thermal protector
M:	Motor

Switch	Full Close	Intermediate	Full Open
CLS 1-2	█	█	█
CLS 1-3	█	█	█
OLS 1-2	█	█	█
OLS 1-3	█	█	█
ACLS 1-3	█	█	█
ACLS 1-3	█	█	█
ACLS 1-2	█	█	█
AOLS 1-3	█	█	█
CTS 1-3	Closing torque switch interrupts control when mechanical overload occurs during closing cycle		
OTS 1-3	Opening torque switch interrupts control when mechanical overload occurs during opening cycle		

ELECTRIC VALVE ACTUATOR TYPE CAR-H

For 2 & 3-way valves type G/L/M/S 2FM-T & G/L/M/S 3FM-T

0-4.11.09-D

Page 5 of 8

110/230 VAC

Wiring diagram CPT for CAR-H 006-010

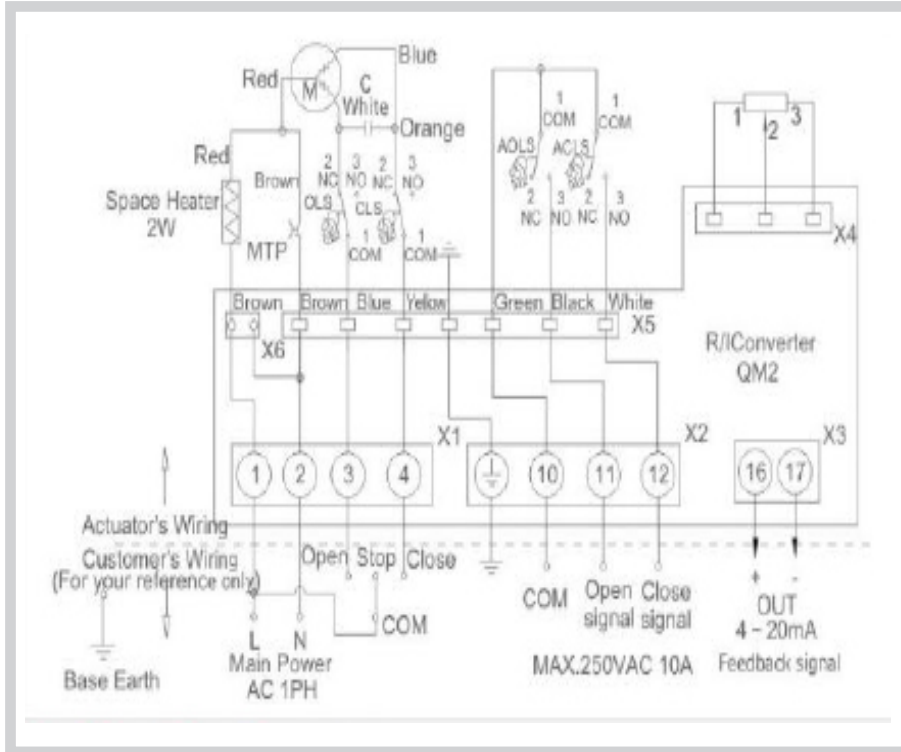

AOLS:	AUX. Open limit switch (250VAC 10A)
ACLS:	AUX. Close limit switch (250VAC 10A)
O:	Open lamp
C:	Close lamp
CLS:	Close limit switch
OLS:	Open limit switch
KMC:	Magnetic contactor close
KMO:	Magnetic contactor open
MTP:	Motor thermal protector
M:	Motor

Switch	Full Close	Intermediate	Full Open
CLS 1-2		—————	—————
CLS 1-3	—————		
OLS 1-2			—————
OLS 1-3	—————		
ACLS 1-3	—————		
AOLS 1-3			—————

110/230 VAC

Wiring diagram CPT for CAR-H 016-S400

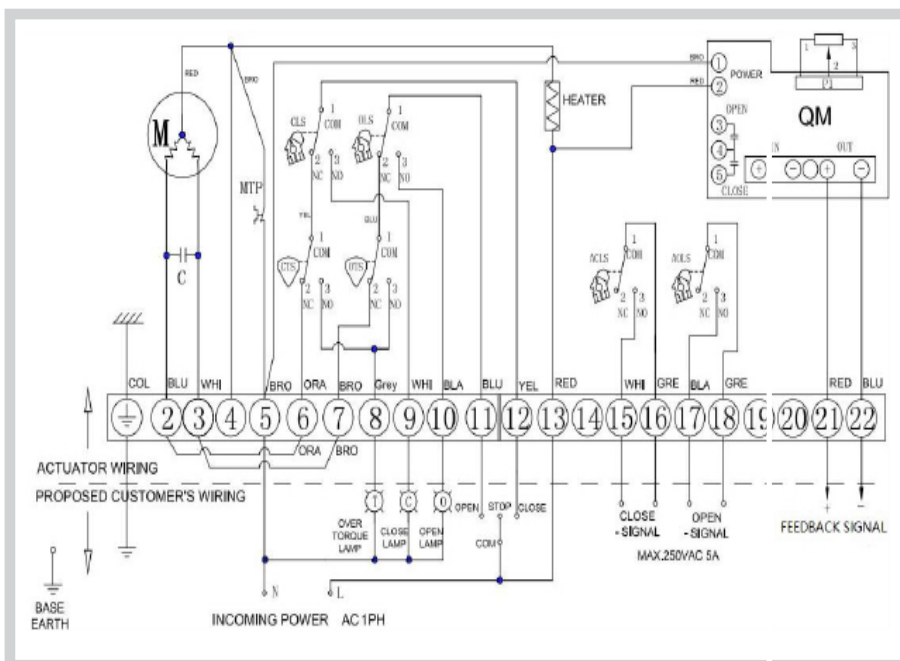

AOLS:	AUX. Open limit switch (250VAC 5A)
ACLS:	AUX. Close limit switch (250VAC 5A)
O:	Open lamp
C:	Close lamp
T:	Torque switch
CLS:	Close limit switch
OLS:	Open limit switch
KMC:	Magnetic contactor close
KMO:	Magnetic contactor open
MTP:	Motor thermal protector
M:	Motor

Switch	Full Close	Intermediate	Full Open
CLS 1-2		—————	—————
CLS 1-3	—————		
OLS 1-2			—————
OLS 1-3	—————		
ACLS 1-3	—————		
AOLS 1-2			—————
AOLS 1-3			—————
CTS 1-3		Closing torque switch interrupts control when mechanical overload occurs during closing cycle	
OTS 1-3		Opening torque switch interrupts control when mechanical overload occurs during opening cycle	

DCV24V
Wiring diagram PCU for CAR-H 006-010

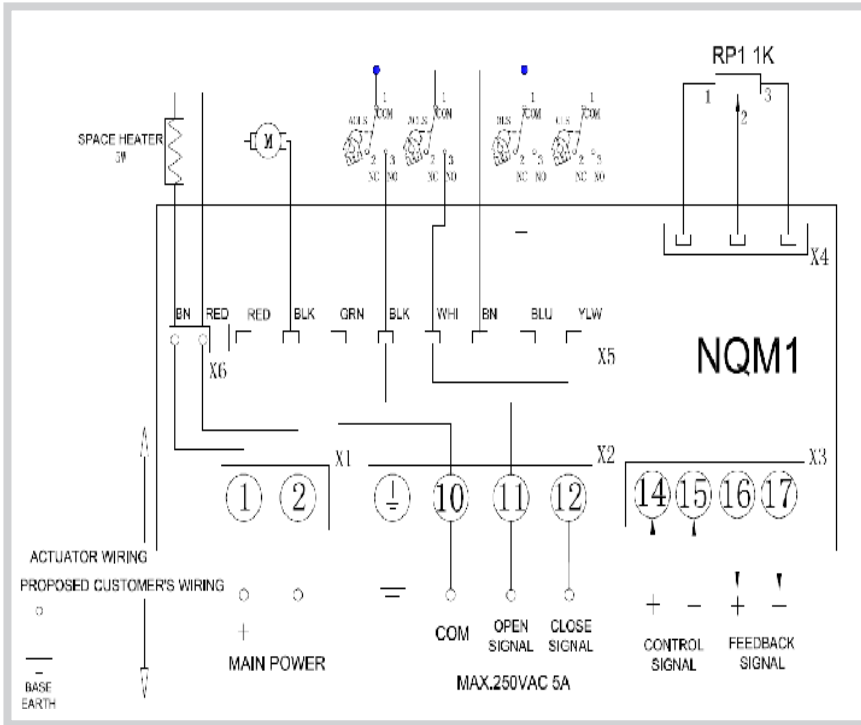

AOLS:	AUX. Open limit switch (250VAC 5A)
ACLS:	AUX. Closeslimit switch (250VAC 5A)
O:	Open lamp
C:	Close lamp
CLS:	Close limit switch
OLS:	Open limit switch
1K:	Potentiometer feedback 1KΩ
M:	Motor

Switch	Full Close	Middle Position	Full Open
CLS 1-2			
CLS 1-3			
OLS 1-2			
OLS 1-3			
ACLS 1-2			
AOLS 1-3			
AOLS 1-2			
AOLS 1-3			

3

DCV24V
Wiring diagram ON/OFF for CAR-H 006-010

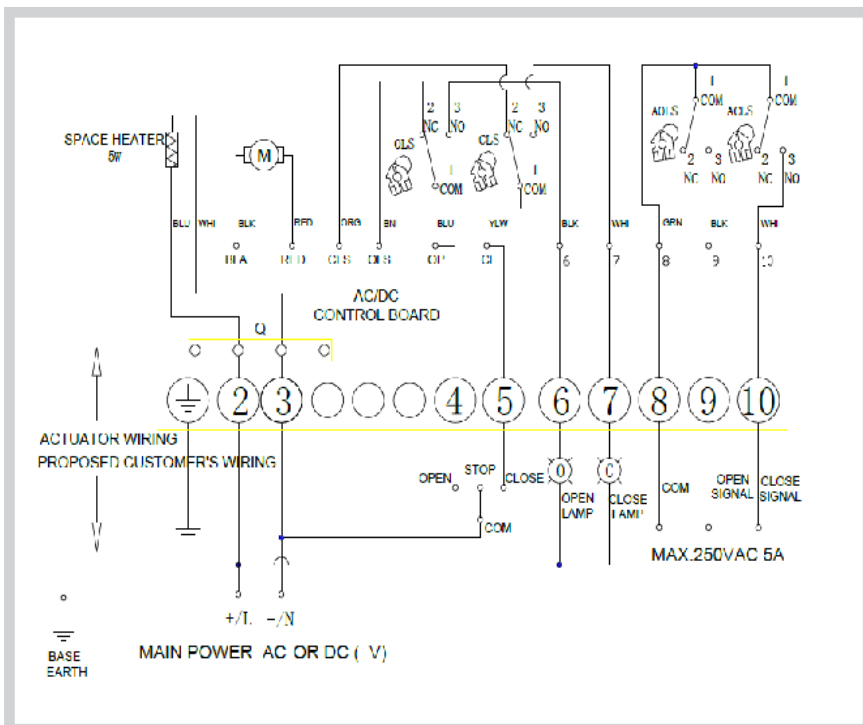

AOLS:	AUX. Open limit switch (250VAC 5A)
ACLS:	AUX. Close limit switch (250VAC 5A)
O:	Open lamp
C:	Close lamp
CLS:	Close limit switch
OLS:	Open limit switch
M:	Motor

Switch	Full Close	Middle Position	Full Open
CLS 1-2			
CLS 1-3			
OLS 1-2			
OLS 1-3			
ACLS 1-3			
AOLS 1-3			

ELECTRIC VALVE ACTUATOR TYPE CAR-H

For 2 & 3-way valves type G/L/M/S 2FM-T & G/L/M/S 3FM-T

0-4.11.09-D

Page 7 of 8

DCV24

Wiring diagram PCU for CAR-H 016-035

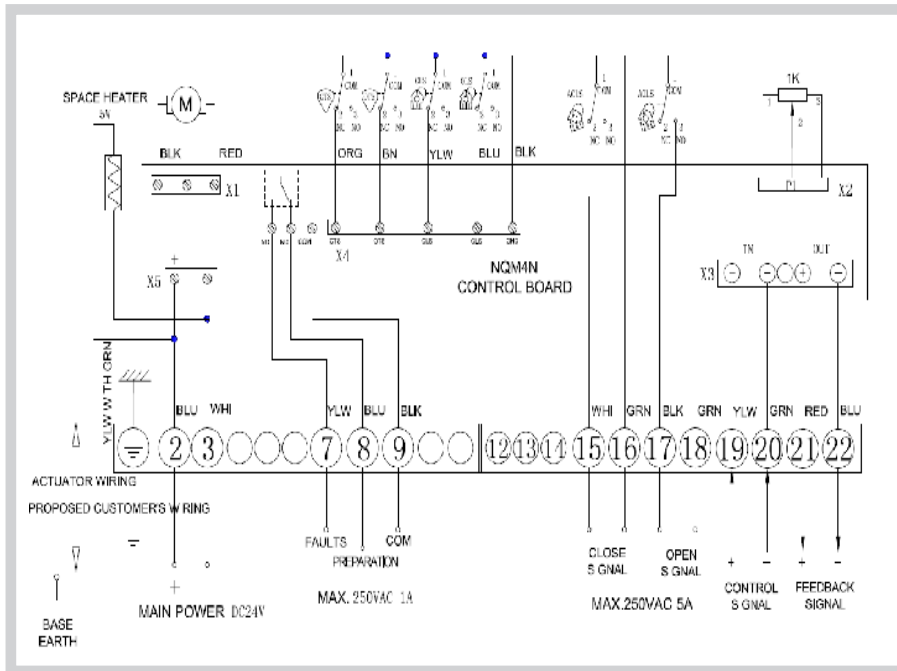

AOLS:	AUX. Open limit switch (250VAC 5A)
ACLS:	AUX. Close limit switch (250VAC 5A)
O:	Open lamp
C:	Close lamp
CLS:	Close limit switch
OLS:	Open limit switch
CTC:	Close torque switch
OTC:	Open torque switch
1K:	Potentiometer 1KΩ
M:	Motor

Switch	Full Close	Middle Position	Full Open
CLS 1-2			
CLS 1-3			
OLS 1-2			
OLS 1-3			
ACLS 1-2			
AOLS 1-3			
AOLS 1-2			
AOLS 1-3			

DCV24

Wiring diagram ON/OFF for CAR-H 016-250

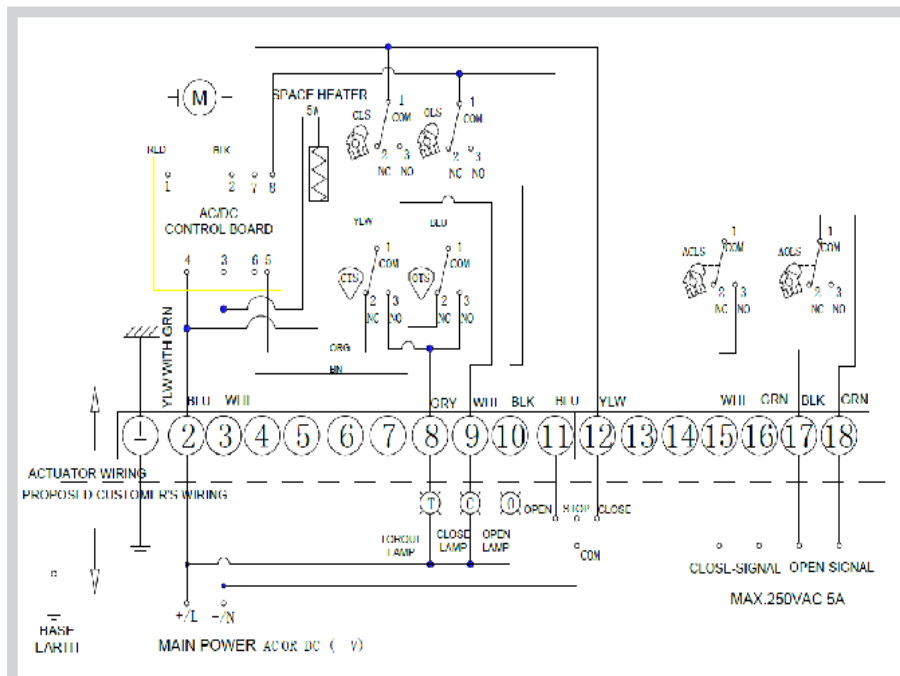

AOLS:	AUX. Open limit switch (250VAC 5A)
ACLS:	AUX. Close limit switch (250VAC 5A)
O:	Open lamp
C:	Close lamp
T:	Torque lamp
CLS:	Close limit switch
OLS:	Open limit switch
CTC:	Close torque switch
OTC:	Open torque switch
M:	Motor

Switch	Full Close	Middle Position	Full Open
CLS 1-2			
CLS 1-3			
OLS 1-2			
OLS 1-3			
ACLS 1-2			
AOLS 1-3			
AOLS 1-2			
AOLS 1-3			

Modulating/PCU actuator data

CAR-H 006-010 Technical data	• Analogue input signal 4-20mA or 0-10V	Optional
	• Analogue feedback signal 4-20mA or 0-10 self-powered	Optional
	• Input impedance $\geq 400K\Omega$	-
	• Dead band 1-%	Adjustable
	• The electronic components are protected dirt and similar	-

CAR-H 016-S250 Technical data	• Analogue input signal 4-20mA or 0-10V	DIP Switches
	• Analogue feedback signal 4-20mA or 0-10V self-powered	DIP Switches
	• Input impedance $\geq 400K\Omega$	-
	• Dead band 1-%	Adjustable
	• The electronic components are protected dirt and similar	-

CLS	Close limit switch (250VAC 5A)	-
OLS	Close limit switch (250VAC 5A)	-
CLS	Close Torque switch (250VAC 5A)	-
OTS	Close Torque switch (250VAC 5A)	-
Torque switch	x 2 close/open	CAR-H 016-S400
Torque switch	without	CAR-H 006-010
TP	Thermal protector (250VAC 5A)	-
Header	CAR-H 006-10: 5W; CAR-H 016-S400: 7W	-

3

AVM234S: 2500N Actuator

(With analog SUT positioner) 2 point or 3 point control and analogue I/O signals

0-99.70.04-B

Page 1 of 2



TECHNICAL DESCRIPTION

Power supply 230 V with modules or direct connection for 24 V~ or 24 V=; continuous activation also permissible at 230 V
 Two-part housing made of fire-retardant yellow plastic and seals to IP66.
 Maintenance-free gearbox of sintered steel, gearbox plate of steel.
 Patented actuator-valve coupling.
 Mounting column made of stainless steel; mounting bracket (for fitting the valve) of aluminium
 Electrical connections (max. 2.5 mm²) with screw terminals.
 Three pre-scored cable inlets for M20×1.5 (2×) and M16×1.5.
 Installation position: vertically upright to horizontal, but not upside down unless protected from dripping water.

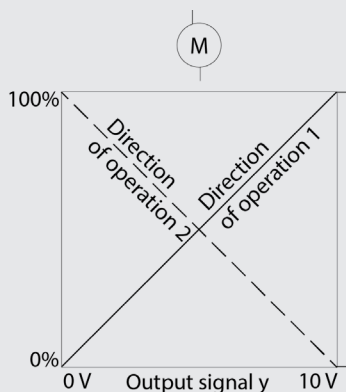

Subject to change without notice.

AREAS OF USE

For use with two or three-way control valves. For controllers with continuous output (0...10 V or 4...20 mA) or switching output (2-point or 3-point control).

HOW ENERGY EFFICIENCY IS IMPROVED

Automatic adaptation to valve, precision control and high energy efficiency with minimal operating noise.

FEATURES

- Pushing force of at least 2500 N
- Stepping motor with SUT (Superior Universal Technology) electronic control unit and electronic load-dependent cut-off
- Automatic detection of control signal applied (continuous or switching), indicated by two LEDs
- The type of characteristic (linear, quadratic or equal-percentage) can be set on the actuator
- Automatically adapts to valve stroke between 8 and 49 mm; captive even in the event of a power failure
- Direction of travel can be selected via screw terminals when making electrical connection or remotely
- Coding switches for selecting the characteristic and the running time (2, 4 or 6 s/mm)
- Lever for external manual adjustment, with motor cut-off, and for triggering a re-initialisation
- Easy assembly with valve; spindle is connected automatically when control voltage is applied

Type	Positioning time (s/mm)	Nominal stroke (mm)
AVM234SK002	2/4/6	49

DIMENSION DRAWING

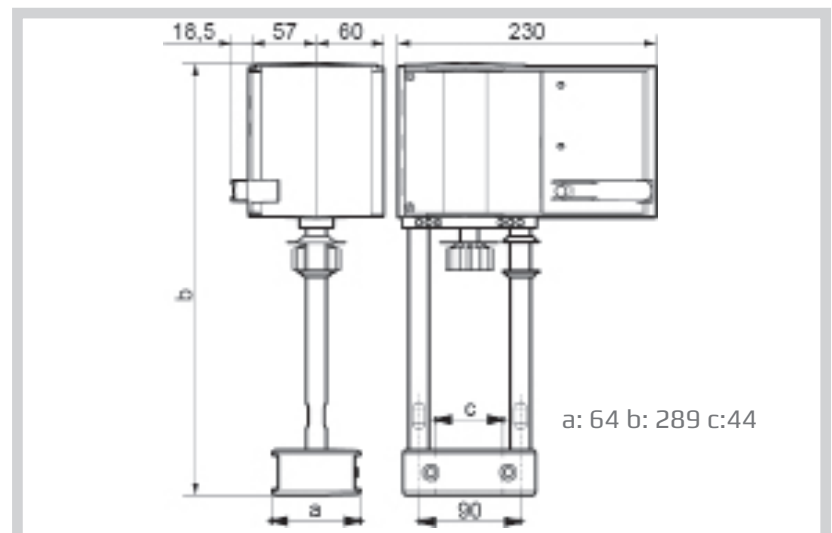

TECHNICAL DATA

Type	Run time s/mm	Stroke mm	Pushing force N	Power supply ¹⁾	Weight kg
AVM 234S K002	2/4/2006	8...40	2500	24 V~/=	4.1
Positioner: ¹⁾					
Control signal 1	0...10 V, R _i > 100 kΩ		Starting point U ₀		0 or 10
Control signal 2	4...20 mA, R _i = 50 kΩ		Control span ΔU		10 V
Position feedback signal	0...10 V, load > 2.5 kΩ		Switching range Xsh		300 mV
Power supply	24 V~ ±20 %, 50...60 Hz		Degree of protection		IP 66 (EN 60529)
with accessories	24 V= ±15%		Protection class		III (IEC 60730)
	230 V~ ±15% 50...60 Hz		Response time for 3-point		200 ms
Power consumption	10 W 18 VA ²⁾		Wiring diagram		A10357
Stroke	8...49 mm		Dimension drawing		M10356
Max temperature of medium	130 °C (option 240 °C) ³⁾		Fitting instructions		99.70.01
Permitted ambient temperature	-10...55 °C		Material declaration		MD 51.377
Permitted ambient humidity	< 95% rh without conversion				

1) Also for 2-point or 3-point depending on the connection for 24 V~

2) Design the transformers for this value, otherwise functional faults may occur.

3) If the temperature of the medium is higher (from 130 °C to 240 °C), an adaptor is required (see accessories)

CE conformity

EMC Directive 2004/108/EC
EN 61000-6-2
EN 61000-6-4

Low-Voltage Directive 2006/95/EC
EN 60730-1
EN 60730-2-14

Over-voltage category III

Degree of pollution III

ACCESSORIES

Type	Description
1-0152285	Temperature adaptor for media temperature > 130 °C ... 240 °C
1-0152287	Potentiometer 1000 Ω , 1 W, 24 V; installation as per MV 505894
1-0152289	Auxiliary change-over contacts (2 pcs. each) 12...250 V Infinitely variable, min. 100 mA and 12 V, additional load 6(2) A, MV 505866
1-0152281	230 V Module, plug-in type , for 2-/3-point and continuous activation, additional power 2 VA 230 V 15% power supply, MV 505901, 50/60 Hz
1-0152287	115 V Module, plug-in type 50/60 Hz
1-0152627	4-20 mA Position feedback signal , for 24VAC/DC, output load resistor max. 600 ohm Accuracy +/- 5% of full range
1-0147655	Cable gland M20×1.5



AVM321/AVM322: 1000N Actuator

For 2-point or 3-point control

0-99.70.05-B

Page 1 of 2



AREAS OF USE

For actuation of 2 and 3-way valves. For controllers with a switching output (2-point or 3-point control)

IMPROVING ENERGY EFFICIENCY

Automatic adaptation to valve, optimal operator convenience, precision control and high energy efficiency with minimal operating noise.

FEATURES

- Synchronous motor with electronic control unit and load - dependent cut-off
- Direction of operation and positioning time can be set using coding switches
- Crank handle for external manual adjustment with motor cut-off
- Very low operating noise
- Simple assembly with valve; spindle is automatically connected after nominal voltage is applied
- Electrical parallel operation of 5 actuators

TECHNICAL DESCRIPTION

Power supply 24 V~/= or 230 V~
Three-piece housing of flame retardant yellow/black plastic and seals with degree of protection IP54.

Maintenance-free gearbox made of plastic, threaded spindle and gearbox base-plates made of steel.

Patented actuator-valve coupling
Mounting studs made of aluminium.
Fixing bracket made of aluminium for the valve fitting with 20 mm and made of plastic for the valve fitting with 10 mm stroke.
Electrical connections (max. 1.5 mm²) with screw terminals.
Two break-out cable inlets for metric screw fitting made of plastic M20×1.5.
Fitting position, vertically upright to horizontal, not upside down unless protected from dripping water.

PRODUCTS

Type	Positioning time (s/mm)	Nominal stroke (mm)	Nominal voltage (V)
AVM321K001	12 (6)	10	230 V~
AVM321K002 ^{*)}	12 (6)	10	24 V~/=
AVM322K001	6 (12)	20	230 V~
AVM322K002 ^{*)}	6 (12)	20	24 V~/=

^{*)} CSA-certified actuators on request (only for devices with nominal voltage 24 V~/=)

DIMENSION DRAWING

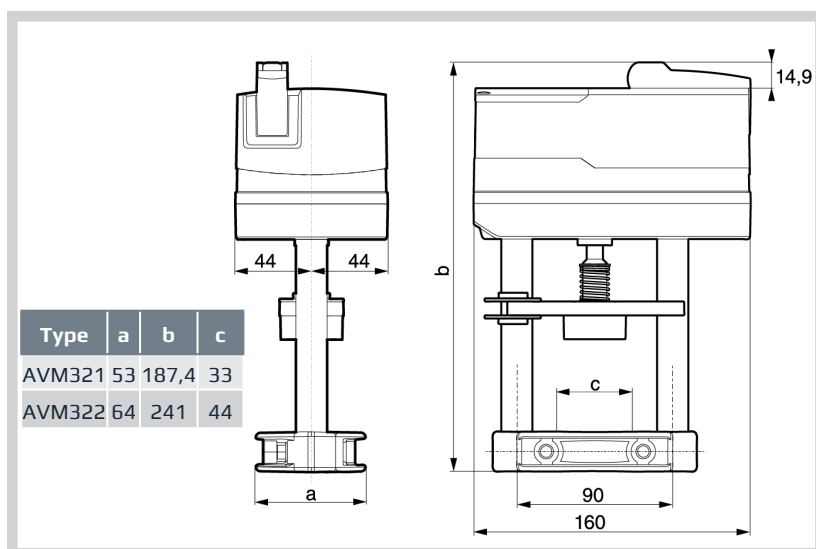

Subject to change without notice.

TECHNICAL DATA

Power supply		
Operating voltage		
	24 V~	±20 %, 50...60 Hz
		24 V=-10%...+20 %
	230 V~	±15 %, 50...60 Hz
Power consumption (at nominal voltage, with movement)		
AVM * K001	< 2.0 W	< 3.0 VA
AVM * K002	< 2.4 W	< 4.0 VA

Parameters	
Nominal force ¹⁾	1000 N
Operating noise ²⁾ (at nominal force)	< 30 dB(A)
Response time	Approx. 200 ms
Max. media temperature ³⁾	0...100 °C

Admissible ambient conditions	
Operating temperature	-10...55 °C
Storage and transport temperature	-40...80 °C
Humidity	5...85% rh
	No condensation

1) Actuating power 1000 N under nominal conditions (24 V or 230 V, 25 °C ambient temperature, 50 Hz). With boundary conditions (19.2 V~ / 28.8 V~ / 21.6 V= / 28.8 V=, -10 °C / 55 °C, 60 Hz) and positioning time, the actuating tensile force is minimised to 800 N

2) Operating noise with the slowest positioning time, test distance 1m

3) Use the appropriate accessory when the temperature of the medium is > 100 °C (temperature adaptor).

POWER CONSUMPTION AT NOMINAL VOLTAGE

Type	Positioning time (s/mm)	Status	Active power P (W)	Apparent power S (VA)
AVM * K001	6 (12)	Standstill *)	< 0,35	≥ 5,0
		Sizing		
	12 (6)	Operation	< 2,4	< 4,0
		Sizing		
AVM * K002	6 (12)	Standstill *)	< 0,3	≥ 4,0
		Sizing		
	12 (6)	Operation	< 2,0	< 3,0
		Sizing		

*) Standstill = actuator in the end position, voltage applied to terminal 1 or 2, motor switched off.

ACCESSORIES

Type	Description
1-0152285	Temperature adaptor for media temperature > 100 °C ... 240 °C
1-0147655	Cable glands M20×1.5 IP68

Installation	
Dimensions W x H x D (mm)	AVM321: 60x187x88 AVM 322: 160x241x88
Weight (kg)	AVM321: 1.5 AVM322: 1.6

Standards and directives	
Degree of protection	IP 54 (EN 60529)
Protection class	II EN60730 III EN60730

Additional information	
Fitting instructions	99.70.03
Declaration on materials and the environment	MD 51.374
Declaration of incorporation	P100012470
Manual & electrical connection diagram	99.70.05.01

3

CE CONFORMITY

EMC Directive 2004/108/EC
EN 61000-6-1
15/9 H1F
EN 61000-6-2
EN 61000-6-3
EN 61000-6-4
Low-voltage Directive 2006/95/EC
EN 60730-1
EN 60730-2-14
Over-voltage category III
Degree of contamination II
Maximum altitude. 2000 m
Machinery Directive 2006/42/EC in accordance with Annex II B
EN 12100

AVM321S/AVM322S: 1000N Actuator

(With analog SUT positioner)

0-99.70.06-B

Page 1 of 2



TECHNICAL DESCRIPTION

Power supply 24 V~ or 24 V= (optional accessory module for 85...265V ac 50/60Hz)

Three-piece housing of flame retardant yellow/black plastic and seals with degree of protection IP54

Maintenance-free gearbox made of plastic, threaded spindle and gearbox base-plates made of steel.

Patented actuator-valve coupling
Mounting studs made of aluminium.

Fixing bracket made of aluminium for the valve fitting with 20 mm and made of plastic for the valve fitting with 10 mm stroke.

Electrical connections (max. 1.5 mm²) with screw terminals.

Two break-out cable inlets for metric screw fitting made of plastic M20×1.5.

Fitting position, vertically upright to horizontal, not upside down unless protected from dripping water.

Subject to change without notice.

AREAS OF USE

For actuation of 2 and 3-way valves. For controllers with constant output (0...10 V / 4...20 mA).

IMPROVING ENERGY EFFICIENCY

Automatic adaptation to valve, optimal operator convenience, precision control and high energy efficiency with minimal operating noise.

FEATURES

- BLDC motor (brushless DC) with electronic control unit SUT
- (Superior Universal Technology) of the third generation and electronic load-dependent cut-off
- Automatic recognition of applied control signal (constant or switched), operating display with bi-coloured LED
- Independent adaptation to the stroke of the valve between 8 and 20 mm
- Very low operating noise
- With the built-in absolute distance measurement system, the position is always maintained in case of power failure
- The direction of operation, characteristic (linear / equal percentage), positioning time and control signal (voltage/current) can be adjusted with coding switches
- Integrated forced operation can be set with coding switches (with selectable direction of operation)
- Easy re-initialisation using a coding switch
- Crank handle for external manual adjustment with motor cut-off
- Simple assembly with valve; spindle is automatically connected after control voltage is applied
- Electrical parallel operation of 5 actuators
- Parameterisation option available through bus interface

PRODUCTS

Type	Positioning time (s/mm)	Nominal stroke (mm)
AVM321SK001 ^{*)}	12 (4)	10
AVM322SK001 ^{*)}	6 (4)	20

^{*)}CSA-certified actuators on request

DIMENSION DRAWING

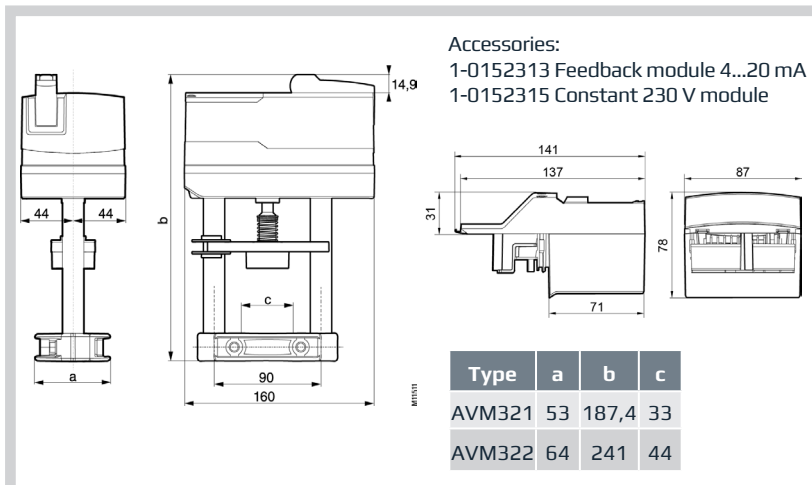

TECHNICAL DATA

Power supply	
Operating voltage	24 V~ ±20 %, 50...60 Hz
	24 V=-10%...+20 %
	230 V~ ±15 % 50...60 Hz
Power consumption (at nominal voltage, with movement)	< 1.7 W, < 3.5 VA

Parameters	
Nominal force ¹⁾	1000 N
Operating noise ²⁾ (at nominal force)	< 30 dB(A)
Response time	> 200 ms
Media temperature ³⁾	0...100 °C Option 240°C
Nominal voltage	24 V~/=
Characteristic	Linear / equal percentage
Positioner ⁴⁾	
Control signal y	0...10 V, R
Control signal y	4...20 mA, R _i ≤ 50 kΩ
Positional feedback signal y ₀	0...10 V, load ≥ 5 kΩ
Starting point U ₀	0 or 10 V
Starting point I ₀	4 or 20 mA
Control span ΔU	10 V
Hysteresis Xsh	160 mV
Control span ΔI	16 mA
Hysteresis Xsh	0.22 mA

¹⁾ Actuating power 1000 N under nominal conditions (24 V, 25 °C ambient temperature, 50 Hz). With boundary conditions (19.2 V~/ 28.8 V~/ 21.6 V= / 28.8 V=, -10 °C / 55 °C, 60 Hz) and positioning time, the actuating tensile force is minimised to 800 N

²⁾ Noise level with the slowest positioning time, test distance 1m

³⁾ Use the appropriate accessory when the temperature of the medium is > 100 °C (temperature adaptor).

⁴⁾ Also for 2- or 3-point, depending on type of connection

POWER CONSUMPTION AT NOMINAL VOLTAGE

Type	Positioning time (s/mm)	Status	Active power P (W)	Apparent power S (VA)
AVM3215	12 / (4)	Operation	< 1.7	< 3.5
AVM3225	6 / (4)	Standstill *	< 0.45	
		Sizing		≥ 4.5

*) Standstill = actuator in the end position, voltage applied to terminal 1 or 2, motor switched off.

ACCESSORIES

Type	Description
1-0152285	Temperature adaptor for media temperature > 100 °C ... 240 °C
1-0152313 *	4...20 mA feedback module, Accuracy +/- 5% of full range
1-0152315 *	Power supply 85-265V 50/60HZ
1-0147655	Cable glands M20x1.5 IP68

*) Dimension drawing or connection diagram is available under the same number

Admissible ambient conditions	
Operating temperature	-10...55 °C
Storage and transport temperature	-40...80 °C
Humidity	5...85% rh No condensation

Installation	
Dimensions W x H x D (mm)	AVM3215 160x187x88 AVM3225 160x241x88
Degree of protection IP 54	(EN 60529)
Weight (kg)	
AVM3215	1.5
AVM3225	1.6

Standards and directives	
Protection class III (EN 60730-1), EN60730-2-14	

Additional information	
Fitting instructions	99.70.03
Declaration on materials and the environment	MD 51.375
Declaration of incorporation	P100012470
Manual & connection diagram	99.70.06.01

CE CONFORMITY

EMC Directive 2004/108/EC
EN 61000-6-1
EN 61000-6-2
EN 61000-6-3
EN 61000-6-4
Low-voltage Directive 2006/95/EC
EN 60730-1
EN 60730-2-14
Over-voltage category III
Degree of contamination II
Maximum altitude. 2000 m
Machinery Directive 2006/42/EC in accordance with Annex II B
EN 12100

AVF234S: 2000N Actuator

With analog SUT positioner (analogue I/O signals) and spring return

0-99.70.07-B

Page 1 of 2



TECHNICAL DESCRIPTION

Power supply 230 V with modules or direct connection for 24 V~ or 24 V=; continuous activation also permissible at 230 V
 Two-part housing made of fire-retardant yellow plastic and seals to IP66
 Maintenance-free gearbox of sintered steel, gearbox plate of steel.
 Patented actuator-valve coupling.
 Mounting column made of stainless steel; mounting bracket (for fitting the valve) of aluminium
 Electrical connections (max. 2.5 mm²) with screw terminals.
 Three pre-scored cable inlets for M20×1.5 (2×) and M16×1.5.
 Installation position: vertically upright to horizontal, but not upside down unless protected from dripping water.

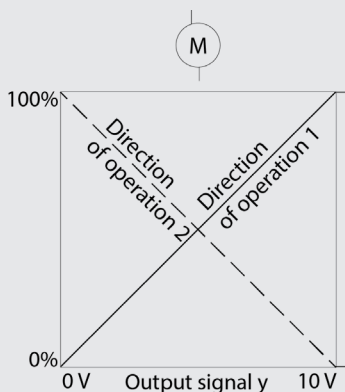

Subject to change without notice.

AREAS OF USE

For use with two or three-way control valves. For controllers with continuous output (0...10 V or 4...20 mA) or switching output (2-point or 3-point control). For applications where a fail-safe function is required.

HOW ENERGY EFFICIENCY IS IMPROVED

Automatic adaptation to valve, precision control and high energy efficiency with minimal operating noise.

FEATURES

- Actuator with spring return action and pushing force of at least 2000 N with actuator extending or retracting spindle versions.
- Stepping motor with SUT (Superior Universal Technology) electronic control unit and electronic load-dependent cut-off
- Automatic detection of control signal applied (continuous or switching), indicated by two LEDs
- The type of characteristic (linear, quadratic or equal-percentage) can be set on the actuator
- Automatically adapts to valve stroke between 8 and 49 mm; captive even in the event of a power failure
- Direction of travel can be selected via screw terminals when making electrical connection or remotely
- Coding switches for selecting the characteristic and the running time (2, 4 or 6 s/mm)
- Lever for external manual adjustment, with motor cut-off, and for triggering a re-initialisation
- Easy assembly with valve; spindle is connected automatically when control voltage is applied
- The availability of numerous adaptors enables the actuator to be fitted to third-party valves

Type	Positioning time (s/mm)	Nominal stroke (mm)
AVF2345K008 Actuator spindle normally retracted	2/4/6	49
AVF2345K009 Actuator spindle normally extended		

DIMENSION DRAWING

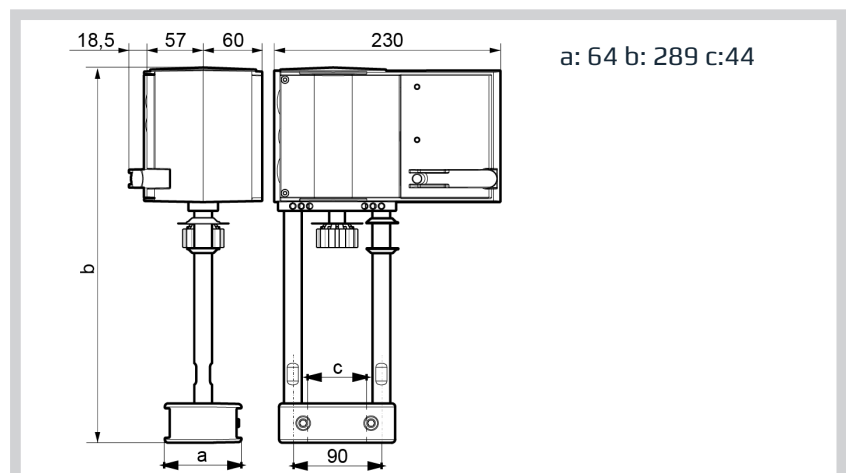

TECHNICAL DATA

Type	Run time s/mm	Stroke mm	Pushing force N	Power supply ¹⁾	Weight kg
AVM 2345 K002 AVF 2345 K009	2/4/2006	8...49	2000	24 V~/=	5.6
Positioner: ¹⁾					
Control signal 1	0...10 V, R _i > 100 kΩ		Starting point U ₀		0 or 10
Control signal 2	4...20 mA, R _i = 50 kΩ		Control span ΔU		10 V
Position feedback signal	0...10 V, load > 2.5 kΩ (Optional: 4-20mA)		Switching range Xsh		300 mV
Power supply	24 V~ ±20 %, 50...60 Hz		Degree of protection		IP 66 (EN 60529)
with accessories	24 V= ±15%		Protection class		III (IEC 60730)
	230 V~ ±15%, 50...60 Hz		Response time for 3-point		200 ms
Power consumption	10 W 18 VA ²⁾		Manual and wiring diagram		99.70.02.02
Stroke	8...49 mm		Dimension drawing		M10356
Number of spring returns	>40.000		Fitting instructions		99.70.02
Spring return time ³⁾	15...30s		Material declaration		MD 51.377
Max. temperature of medium	130 °C (Option 240°C) ⁴⁾				
Permitted ambient temperature	-10...55 °C				
Permitted ambient humidity	< 95% rh without condensation				

1) Also for 2-point or 3-point depending on the connection for 24 V~

2) Design the transformers for this value, otherwise functional faults may occur.

3) The return time corresponds to a stroke of 14 to 40mm and does not depend on the set run time

4) If the temperature of the medium is higher (from 130 °C to 240 °C), an adaptor is required (see accessories)

CE conformity

EMC Directive 2004/108/EC

EN 61000-6-2 ¹⁾

EN 61000-6-4

Low-Voltage Directive 2006/95/EC

EN 60730-1

EN 60730-2-14

Over-voltage category III

Degree of pollution III

ACCESSORIES

Type	Description
1-0152285	Temperature adaptor for media temperature > 130 °C ... 240 °C
1-0152287	Potentiometer 1000 Ω , 1 W, 24 V; installation as per MV 505894
1-0152289	Auxiliary change-over contacts (2 pcs. each) 12...250 V Infinitely variable, min. 100 mA and 12 V, additional load 6(2) A, MV 505866
1-0152281	230 V Module, plug-in type , for 2-/3-point and continuous activation, additional power 2 VA 230 V 15% power supply, MV 505901
1-0152627	4-20 mA Position feedback signal , for 24VAC/DC, output load resistor max. 600 ohm Accuracy +/- 0,25% of full range
1-0147655	Cable gland M20x1.5 IP68
1-0145537	Cable gland M16x1.5 IP68

Electric Actuator Linear CAL M301 & M302

with manual override and 2-point or 3-point control and analog I/O signals

0-4.20.01-B

Page 1 of 2



TECHNICAL DATA

Material - Body and cover:	Aluminum/polycarbonate RAL6018 green
Material - Pillar:	Steel. 1.4104
Material - Bracket:	Galv. steel 1.0037
Weight:	5.6 kg without accessories
Handwheel and positioner:	Integrated
Stroke:	from 5mm - max 40mm
Power supply:	24 VAC/DC, 100 - 240 VAC, $\pm 10\%$
Control signals:	2 and 3-point control signals 24 AC/DC, 100 - 230 VAC. Analog I/O signals 0-20 mA, 4-20 mA, 0-10V, 2-10 V
Duty cycle according to IEC 60034-1.8	
Binary ON/OFF:	52 - 30 min 50% ED
Modulating:	54 - 1200 c/h 50% ED
Valve positioner function:	Integrated, dead band 0.6% of full signal range, shut-off minimum
Manual override:	Electrically via 2 push buttons and handwheel
Permitted ambient temp:	-20 to +60°C
Operating speed:	0.6 / 0.9 / 1.2 mm/s
Enclosure acc. to EN 60529:	IP65
Overvoltage category:	CAT III
Minimum force:	1 kN - Type M301 2 kN - Type M302
Power consumption:	Type M301 - 9 W Type M302 - 12 W

Subject to change without notice.

APPLICATION

The Electric valve actuator type CAL is specifically designed to meet the demands of the powerful low frequency vibration environments in marine installations as well as in other demanding environments.

The main applications are heating, cooling, ventilation and industrial systems where the medium is water, steam or oil. The actuator is designed to be used with Clorius 2-way and 3-way linear control valves.

DESIGN

Linear actuator with manual override, power supply with direct connection for 24 VAC/DC.

Also available with a wide range power supply module (100 - 240 VAC) Gearbox made of high quality aluminum die casting, powder-coated (60 μm thickness).

FUNCTION

Brushless DC motor (BLDC) driving the gear system. This turning is converted into an upward and downward motion via the crank mechanism.

FEATURES

- Robust and compact design
- Low installation height
- Easy valve mounting
- Contactless, non-wearing travel detection with Hall sensor for exact positioning
- Durable aluminum gearbox
- Brushless DC motor
- Manual operation with push buttons and handwheel

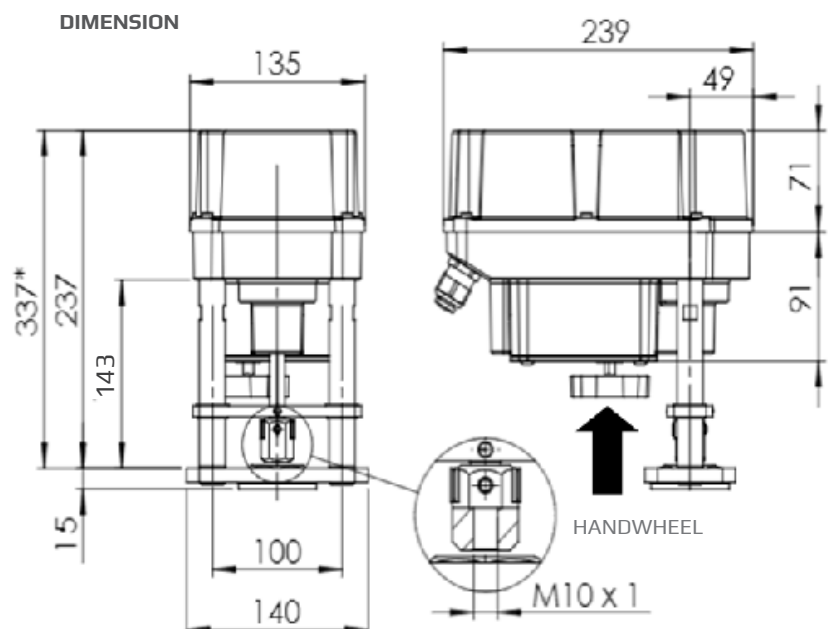

*FOR TEMPERATURES UP TO 240°C

MOUNTING

Vertically upright to horizontal, but not upside down unless protected against dripping liquids

Delivered with cable glands for correct installation, M20 x 1.5 (x2) and M16 x 1.5 (x1)

Electrical connections (max. 2.5 mm² wire) with screw terminals

The instructions supplied with the actuator must be followed carefully for mounting and start-up

TABLE 1

PRODUCT NO.	TYPE	FORCE (kN)	STROKE (mm)
1-5231960	ACTUATOR CAL-M301 24 VAC/DC	1	40
1-5231962	ACTUATOR CAL-M301 WITH POWER MODULE 100-240 VAC	1	40
1-5231965	ACTUATOR CAL-M302 24 VAC/DC	2	40
1-5231967	ACTUATOR CAL-M302 WITH POWER MODULE 100-240 VAC	2	40

TABLE 2

PRODUCT NO.	ACCESSORIES	
1-0156919	MODULE 100-240 VAC FOR M301 AND M302	Module 100 - 240 VAC
1-0156955	TEMPERATURE ADAPTOR CAL M301 AND M302	Adapter for temperatures up to 240°C
1-0156957	POSITION SIGNAL SWITCHES	2 potential-free position switches, mechanical, with silver changeover contacts (0.1 A - 5 A switching current)
1-0156959	POSITION SIGNAL RELAYS	Switching points can be adjusted from 0 - 100% of the stroke using potentiometers 2 position signal relays with changeover contacts, calibrated automatically to valve stroke 24V to 230V AC/DC 0.1 A - 1 A

BETTER EFFICIENCY IN ENERGY GENERATION

Our electric controllers ensure a better efficiency in energy generation and energy conversion in marine, industry and HVAC systems.



**CONTROLLER ER 2022 &
ER 2025**

ELECTRIC CONTROLLERS

4

OUR ELECTRIC CONTROLLERS PROGRAM INCLUDES:

CONTROLLER TYPE

ER 2022
ER 2022A
ER 2022S (SMART)
ER 2022SA (SMART ANALOG)

USAGE

CONSTANT TEMPERATURE CONTROL

Compact Controller type ER 2022 & ER 2022A

For Electronic Temperature Control

0-4.6.02-D

Page 1 of 4



APPLICATIONS

The ER 2022 and ER 2022A controller are used for constant temperature control. It is suitable for all heating and cooling control systems. The controller is primarily intended for marine installations and other industrial applications - such as cooling water and lubricating oil installations, flow temperature control etc.

DESIGN

The device is characterized by a simple, clearly structured operation supported with texts. Process values and parameters are represented by two 18-segment LCD displays. The ER 2022 and ER 2022A type are additionally equipped with a pixel matrix LCD display for displaying text. In addition, the device has individual display elements for the switch positions of the outputs as well as for manual mode. The device is operated using a membrane keyboard with four buttons and can be used under harsh environmental influences thanks to the high IP65 protection.

The ER 2022 and ER 2022A includes, a program controller, manual mode, limit value monitoring functions, digital control signals.

FUNCTION

The temperature input comes via a Pt100 sensor with a single sensing element. The measured value of the controlled variable is compared with the set point value and adjusted via a PI or a PID control structure.

The ER 2022 & ER 2022A can act as either a heating controller, the actuator closes at rising temperature, or as cooling controller, the actuator opens at rising temperature.

The ER 2022 & ER 2022A permits direct reading of the actual temperature value (PV) and it is secured from failure in the measuring circuit i.e. the controller can be set to give either a closing, an opening or remain in current position command in case of sensor short circuit or sensor break. The error message Err appears in the LED display PV.

FEATURES

- **PI and PID performance**
- **Easy operation**
- **For heating and cooling systems in maritime and industrial installations**
- **Manual and automatic changeover**
- **Robust self-optimization**
- **Alarm indicating a deviation from set point, positive or negative**
- **Only one sensor element Pt 100 required for control and temperature indication**
- **User-defined operation**
- **3 positional output for controlling the actuator**

COMMUNICATION

The controller is equipped with a RS 485 communication module.

TECHNICAL DATA

Line voltage

110-240 V AC -15 % /+10 %, 48-63 Hz
20-30 V AC/DC -15 % /+10 %, 48-63 Hz - optional

Power consumption

Approx. 6,6 VA
Measuring rate: -200°C/+850°C or -328°F/+1562°F

Permissible ambient temperature

Operation -10 to +55°C
Transport and storage -30 to +70°C

Degree of protection

Front IP 65 according to DIN 60529
IP20 on the back

Design

For control panel installation 96 x 96 x 65 mm
(W x H x D) panel cut out 92 x 92 mm

Installation position

Arbitrary

Set-point values

4 available

ER 2022

Input: Pt100, 0-10V, 2-10V, 0-20mA, 4-20mA
Output: 3-point

ER 2022A

Analog Input: Pt100, 0-10V, 2-10V, 0-20mA, 4-20mA
Analog output: 0-10V, 2-10V, load resistance >500Ω
20mA, 4-20mA, load resistance >450Ω

Measuring accuracy 0.1% of the measuring range

Overvoltage Category III

Displays 18-segment LCD displays
24,8 mm x 12 mm

Alarm

Alarm functions work with a fixed limit value which corresponds to the limit value entered
ER 2022 1xAlarm and ER 2022A 2xAlarm

Relay (N/O) 3x switching capacity - 230 V AC/3A

Electric connection Conductor cross section
wire min.0,2 mm², max 1,5 mm²

Data protection Semi - conductor memory

Weight Approx. 0,22 kg

Approvals DNV GL – on request

WIRING DIAGRAM - ER 2022 - 3-POINT OUTPUT

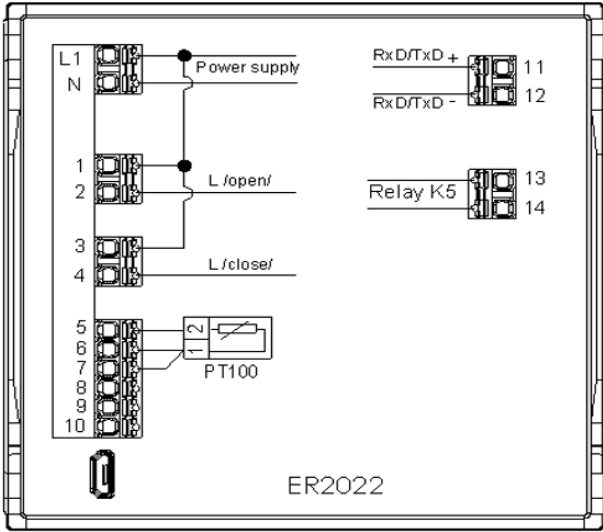

ER 2022 TERMINALS	CONNECTION
L1 (+) - N	Voltage supply 24VAC/DC - 110-240VAC
1 - 2	Output 1 (relay)
3 - 4	Output 2 (relay)
5 (+) - 6 - 7	Input/Pt100 - three-wire
5 - 7	Input/Pt100-two-wire
6(+)- 7(-)	Input 0-20mA or 4-20mA
8(+)* 7(-)	Input 0-10V or 2-10V
8 - 9 - 10	Set point SP 1-4 changeover
11(+)- 12(-)	RS485
13 - 14	ALARM

ELECTRICAL CONNECTIONS POWERED 110-240VAC - OPTIONAL EXTERNAL UNITS 3-POINT OUTPUT

UNIT	TERMINALS	CAR	TERMINAL
ER 2022	Voltage supply	L	-
		N	3
	Output 1	2	10
		4	11

UNIT	TERMINALS	UNIT	TERMINAL
ER 2022	Voltage supply	L	-
		N	MM/N
	Output 1	2	.01
		4	.02

UNIT	TERMINALS	CAR	TERMINAL
ER 2022	Voltage supply	L	-
		N	3
	Output 1	2	4
		4	5

UNIT	TERMINALS	UNIT	TERMINAL
ER 2022	Voltage supply	L	-
		N	N
	Output 1	2	2a
		4	2b

UNIT	TERMINALS	CAR	TERMINAL
ER 2022	Voltage supply	L	-
		N	5
	Output 1	2	11
		4	12

UNIT	TERMINALS	UNIT	TERMINAL
ER 2022	Voltage supply	L	21
		N	N
	Output 1	2	2a
		4	2b

UNIT	TERMINALS	CAR	TERMINAL
ER 2022	Voltage supply	L	X5-2
		N	X5-1 AND X1-2
	Output 1	2	X1-1
		4	X1-3

* AVM321/322/3215/3225 and AVM234: Please refer to instruction depending on the type

Compact Controller type ER 2022 & ER 2022A

For Electronic Temperature Control

0-4.6.02-D

Page 3 of 4

WIRING DIAGRAM - ER 2022A- ANALOG

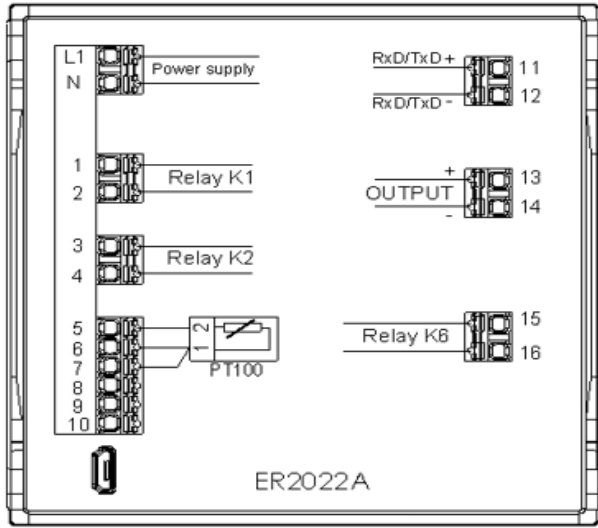

ER 2022 TERMINALS	CONNECTION
L1 (+) - N	Voltage supply 24 VAC/DC -110-240VAC
1 - 2	Output K1 (relay)
3 - 4	Output K2 (relay)
5 (+) - 6 - 7	Input/Pt100 - three-wire/
5 - 7	Input/Pt100-two-wire/
6(+)- 7(-)	Input 0-20mA or 4-20mA
8(+)- 7(-)	Input 0-10V or 2-10V
8 - 9 -10	Set point SP 1-4 changeover
11 (+) - 12 (-)	R5485
13(+)- 14(-)	Output analog signal
15-16	ALARM

ELECTRICAL CONNECTIONS 110 - 240VAC - OPTIONAL EXTERNAL UNITS

UNIT	TERMINALS	UNIT	TERMINAL
ER 2022A	Voltage supply	L	1
		N	2
	Control signal 4-20mA	13	5-6 (bridge)
		14	Input (-)
			Input (+)

UNIT	TERMINALS	UNIT	TERMINAL	
ER 2022A	Voltage supply	L	L	
		N	N	
	Control signal	13	AVM 3215K/3225K	03
		14		MM

UNIT	TERMINALS	UNIT	TERMINAL
ER 2022A	Voltage supply	L	2
		N	1
	Control signal 4-20mA	13	14
		14	15

UNIT	TERMINALS	UNIT	TERMINAL	
ER 2022A	Voltage supply	L	21 & 2a or 2b	
		N	N	
	Control signal	13	AVF2345K	3i
		14		1

UNIT	TERMINALS	UNIT	TERMINAL
ER 2022A	Voltage supply	L	13
		N	5
	Control signal 4-20mA	13	13-14 (bridge)
		14	19
			20

UNIT	TERMINALS	UNIT	TERMINAL	
ER 2022A	Voltage supply	L	2a or 2b	
		N	N	
	Control signal	13	AVM2345K	3i
		14		1

* AVM321/322/3215/3225 and AVM234: Please refer to instruction depending on the type

UNIT	TERMINALS	UNIT	TERMINAL	
ER 2022A	Voltage supply	L	X5-2	
		N	X5-1	
	Control signal 4-20mA	13	M301/302	X3-1
		14		X2-1

Subject to change without notice.

DIMENSIONS IN MM/INCH

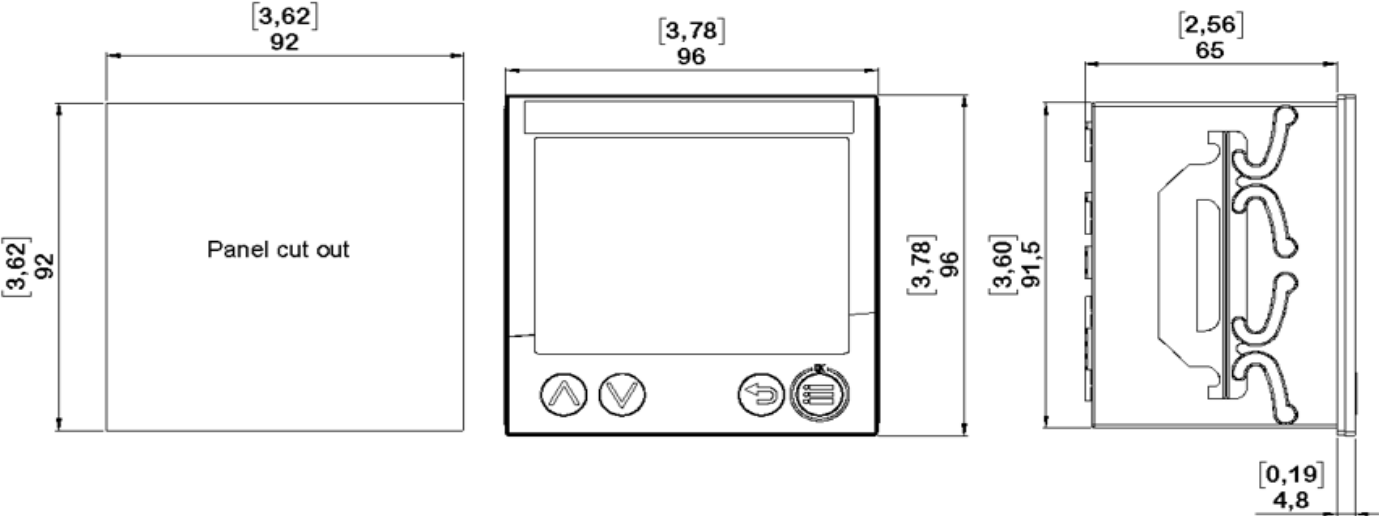

Compact Controller type ER 2025S (Smart) & ER 2025SA (Smart Analog)

For Electronic Temperature Control

0-4.6.04-B

Page 1 of 4



TECHNICAL DATA

Line voltage

110 - 230V AC -15% /+10%, 48-63 Hz
24V AC/DC -15% /+10%, 48-63 Hz - **optional**

Power consumption

Approx. 6,8 VA

Measuring rate: -200°C/+850°C or -328°F/+1562°F

Permissible ambient temperature

Ambient -10 to +55°C

Transport and storage -30 to +70°C

Degree of protection

Front IP 65 according to DIN 60529

IP20 on the back

Design

For control panel installation 96 x 96 x 115 mm
(W x H x D) panel cut out 92 x 92 mm

Installation position

Horizontal

Set-point values

4 available

ER 2025S - 3-Point

Input: Pt100, 0-10V, 2-10V, 0-20mA, 4-20mA

Output: 3-point and 2 x 4-20mA

ER 2025SA - Analogue

Analogue Input: Pt100, 0-10V, 2-10V, 0-20mA, 4-20mA

Analogue output: 2 x 4-20mA

Measuring accuracy

0.1% of the measuring range

Over voltage

Category II

Displays

18-segment LCD displays
24,8 x 12mm

Alarm

Alarm functions work with a fixed limit value which corresponds to limit value entered

Relay (N/O contact)

Switching capacity: 230V AC/3A

Relay (changeover)

Switching capacity: 230V AC/8A

Electric connection

Conductor cross section
wire min 0,2 mm² - max 1.5mm²

Data protection

Semi - conductor memory

Weight

Approx. 0,41 kg

Approvals

DNV GL - on request

APPLICATIONS

The ER 2025S and ER 2025SA controllers are used for constant temperature control. They are suitable for all heating and cooling control systems. The controller is primarily intended for marine installations and other industrial applications - such as cooling water and lubricating oil installations, flow temperature control and where it is needed to use remote set point function.

DESIGN

The device is characterized by a simple, clearly structured operation supported with texts. Process values and parameters are represented by two 30-segment LCD displays. The ER 2025S and ER 2025SA types are additionally equipped with a pixel matrix LCD display for displaying text. In addition, the device has individual display elements for the switch positions of the outputs as well as for manual mode. The device is operated using a membrane keyboard with four buttons and can be used under harsh environmental influences thanks to the high IP65 protection.

The ER 2025S and ER 2025SA includes, a program controller, manual mode, limit value monitoring functions, digital control signals.

FUNCTION

The temperature input comes via a Pt100 sensor with a single sensing element or from other devices/Remote set point. The measured value of the controlled variable is compared with the set point value and adjusted via a PI or a PID control structure.

The ER 2025S & ER 2025SA can function as either heating or cooling controllers the actuator closes at rising temperature, or as a cooling controller, the actuator opens at rising temperature.

The controller permits direct reading of the actual temperature value and it is secured from failure in the measuring circuit, i.e. the controller can be set to give either a closing, an opening or stay in current position command in case of sensor short circuit or sensor break. The error message appears in the LED display.

FEATURES

- **PI and PID performance**
- **Easy operation**
- **For heating and cooling systems in maritime and industrial installations**
- **Manual and automatic changeover**
- **Robust self-optimization**
- **Changeover from remote analog set point to local set point Pt100 and vice versa**
- **Alarm indication a deviation from det point, positive or negative**
- **Only one sensor element Pt 100 required for control and temperature indication**
- **User-defined operation**
- **3 positional output for controlling the actuator**

COMMUNICATION

The controller is equipped with a RS 485, PROFINET communication module or ENETHERNET communication module - on request.

Subject to change without notice.

WIRING DIAGRAM - ER 2025S - 3-POINT OUTPUT

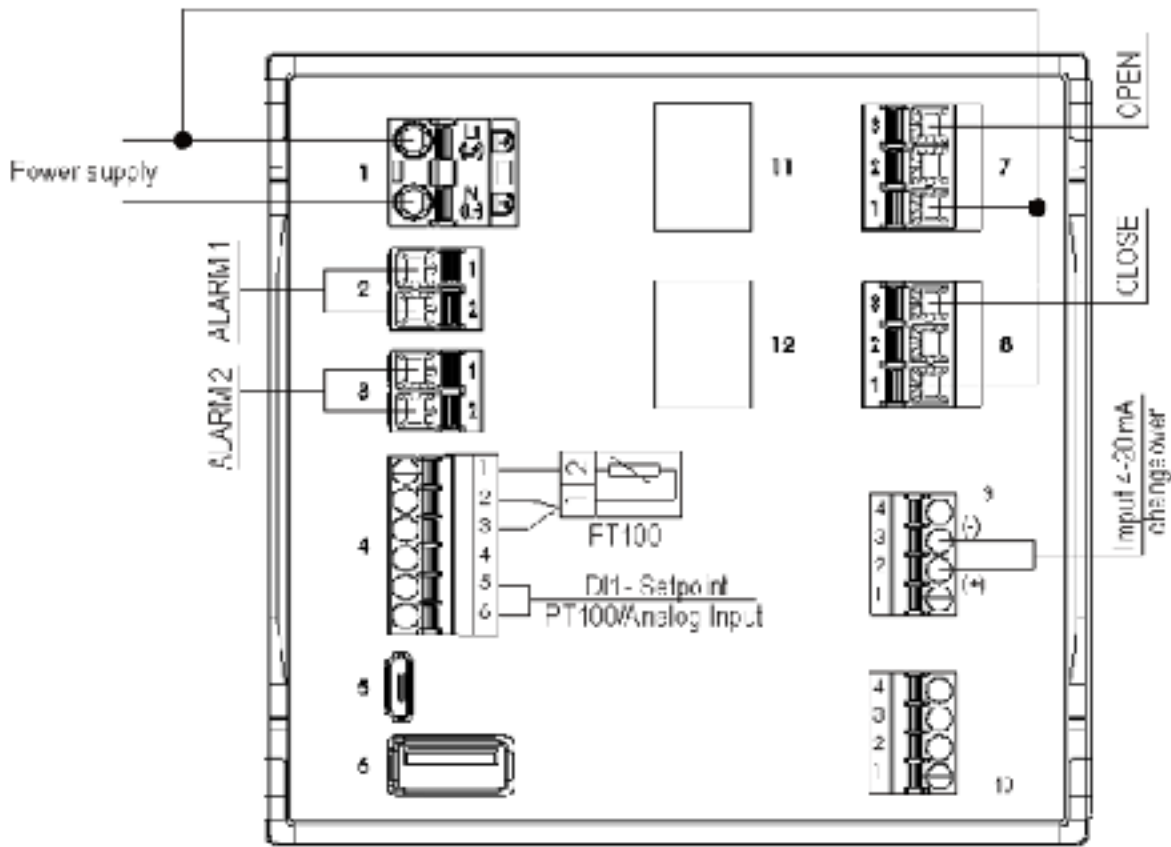

4

TERMINAL	CONNECTION	DESCRIPTION
Block 1		
L1(+) and N(-)	Voltage supply 110-240VAC 24ACDC-Option	
Block 2		
1	ALARM	
2		
Block 3		
1	ALARM	
2		
Block 4		
1	INPUT/Pt100 - three -wire/white	
2	INPUT/Pt100 - two -wire/red	
3	INPUT/Pt100 - two-wire/red	
5	DI-1 - Digital setpoint settings	Pt100/analog 4-20mA
6		

TERMINAL	CONNECTION	DESCRIPTION
Block 7		
1	Relays 230V/8A - OUTPUT	
3		3 to actuator OPEN
Block 8		
1	Relays 230V/8A - OUTPUT	
3		3 to actuator CLOSE
Block 9		
2	Input signal 4-20mA(+)	Set point controller signal 4mA - 65°C/20 mA - 95°C
3	Input signal 4-20mA(-)	

Compact Controller type ER 2025S (Smart) & ER 2025SA (Smart Analog)

For Electronic Temperature Control

0-4.6.04-B

Page 3 of 4

WIRING DIAGRAM - ER 2025SA- ANALOG

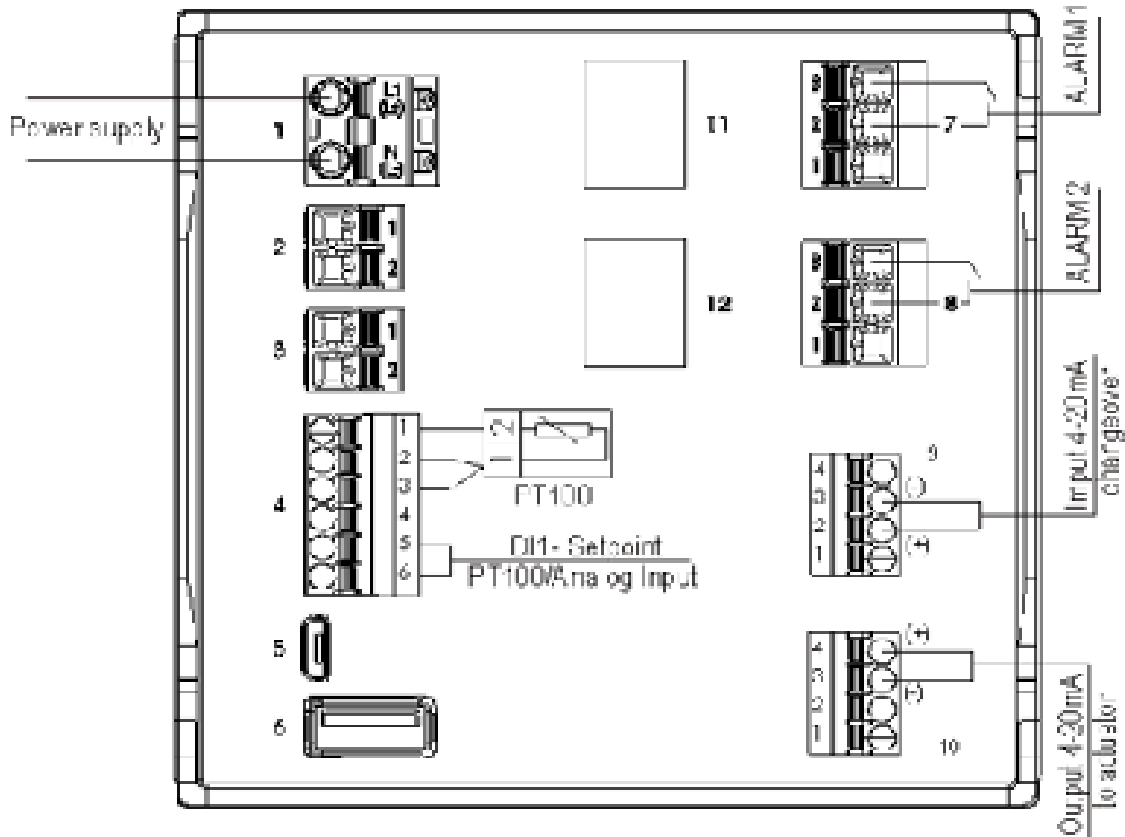

TERMINAL	CONNECTION	DESCRIPTION
Block 1		
L1(+) and N(-)	Voltage supply 110-240VAC 24ACDC-Option	
Block 7		
3	ALARM	
2		
Block 8		
3	ALARM	
2		

TERMINAL	CONNECTION	DESCRIPTION
Block 4		
1	INPUT/Pt100 - three -wire/white	
2	INPUT/Pt100 two -wire/red	
3	INPUT/Pt100 two -wire/red	
5	DI-1 - Display set point settings	Pt100/analog 4-20mA
6	DI-1 - Display set point settings	
Block 9		
2	Input signal 4-20mA(+)	Set point controller signal 4mA - 65°C/20 mA - 95°C
3	Input signal 4-20mA(-)	
Block 10		
3	Input signal 4-20mA(+)	To actuator
4	Input signal 4-20mA(-)	

Subject to change without notice.

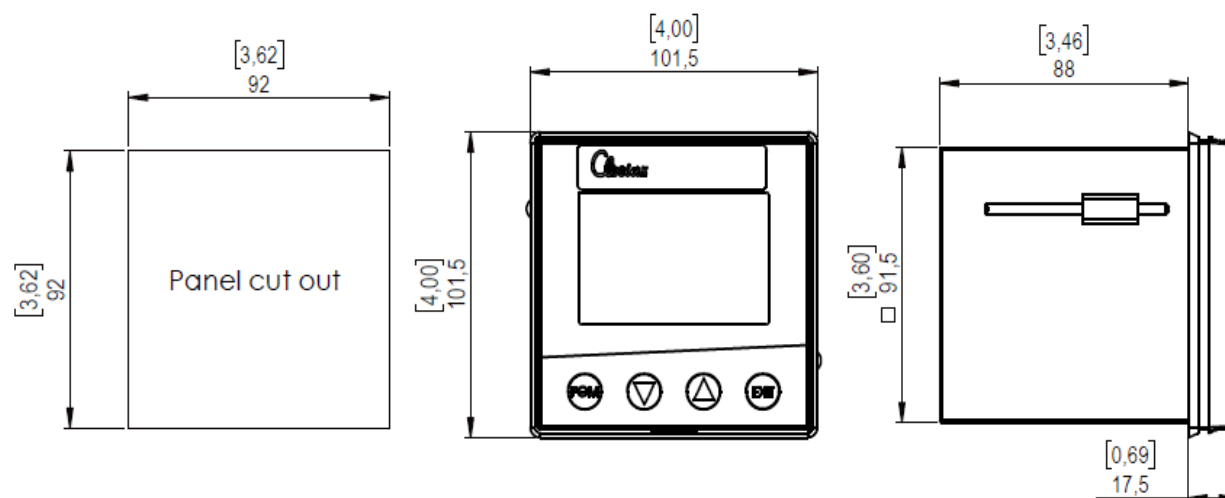
DIMENSIONS IN MM/INCH**CAUTION:**

Use always shielded cables.

It is recommended to use the cable end clamps when installing wire.

ELECTRIC CONNECTION:

At the back, via screw terminals, conductor cross-section up to 2.5mm² With core ferrules (length: 10mm)

**PRECISION PERFORMANCE
& RELIABILITY**

Reliable and efficient pneumatic actuators for extreme environments and critical applications without compromising performance or safety.

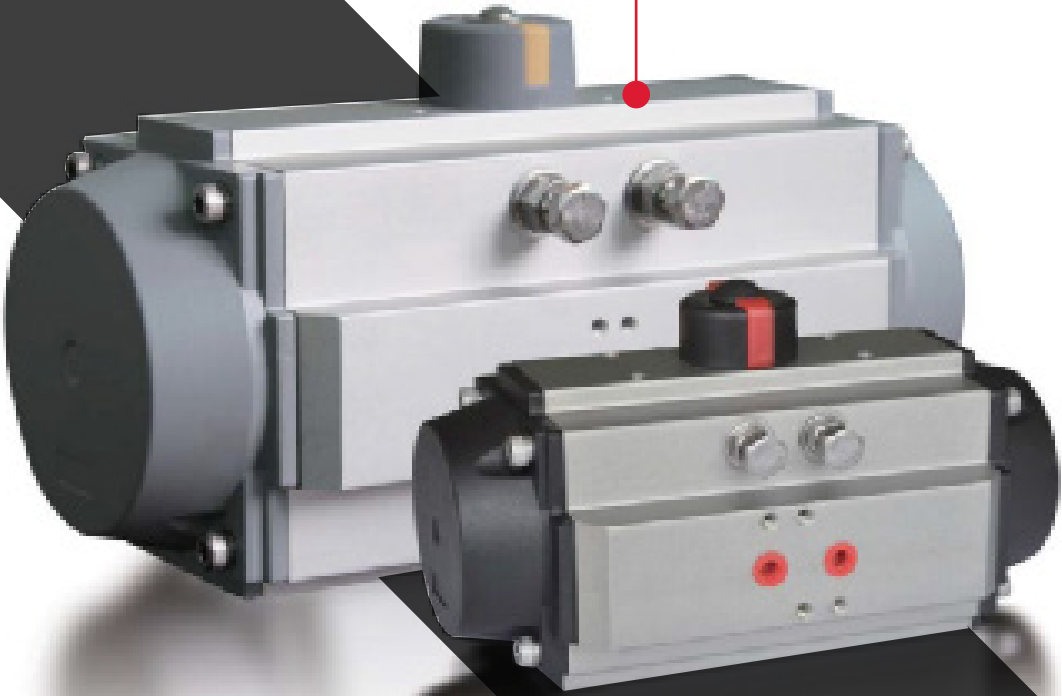

PNEUMATIC ACTUATORS

5

OUR PNEUMATIC ACTUATOR PROGRAM INCLUDES:

ACTUATOR TYPE

ROTARY PNEUMATIC
LINEAR PNEUMATIC

USAGE

VT SINGLE AND DOUBLE ACTING
516, 525, 534

Pneumatic Actuator

Series S

0-6.5.01-E

Page 1 of 2



TECHNICAL DATA

Material:	
- Body	Polyester coated steel
- Stem	Stainless steel 1.4301
- Tie rods	Stainless steel AISI 316
- Mounting plate	Polyester coated steel
- O-rings	NBR (Nitrile rubber)
- Diaphragm	Neoprene rubber w/terylene support
- Springs	Galvanized steel
Air quality	Dry and filtrated air, non aggressive gasses
Air supply	Max. 6 bar
Air supply connect.	1/8" RG Female
Temperature	-25°C to +115°C
Acting mode:	
- Type SC: Spring close / Air open (NC)	
- Type SO: Spring open / Air close (NO)	
Data sheet	0-6.5.01-E

APPLICATIONS

Pneumatic actuator for actuating and control of Clorius valves in various environments.

Relevant datasheets for accessories to the S actuators:

- Positioners	0.6.6.01, 0.6.6.02
- Filter regulators	0.6.8.01
- Controller	ER2022 0.4.6.02
- Sensor	PT100 0.4.25.01
- Pneumatic controller	580 0.6.7.01

DESIGN

Compact pneumatic actuator with rolling diaphragm and multiple internal compression springs for operating Clorius valves.

Reinforced rolling diaphragm guarantees long lifetime and reliable, safe operation. Maintenance or change of operating method does not require any special tools.

FUNCTION

The pneumatic actuator is powerful with a high control speed compared to electric actuators. The linear actuator has a simple and light design with a minimum of moving parts. The pneumatic actuator are also low maintenance due to the simple design and the few moving parts. The linear actuator is ideal for on/off and control functions of globe valves. The spring loaded actuator offers the possibility for a fail-safe function, the safety installation is low cost compared to example battery backup. The pneumatic actuator can be used in Eex areas, without extraordinary encapsulation or other precautions.

FEATURES

- Linear characteristic
- Multispring diaphragm actuator
- Compact design with low weight
- Diaphragm with vulcanised terylene support secures a long and safe life-time

DIMENSION SKETCH

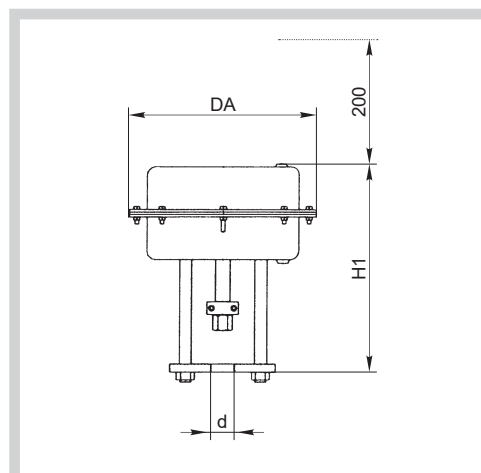

Type	d mm	DA mm	H1 mm	Travel mm
S16	25	160	237	20
S25	35	250	277,5	20
S34	32	340	350	33.5

Subject to change without notice.

Actuator	Type	Force	Travel (max)	Min. pressure to close valve	Min. pressure to open valve
S16	SC	1270 N	20 mm	-	1.1 Bar
	SO	925 N	20 mm	0.8 Bar	-
S25	SC	9090 N	20 mm	-	2.9 Bar
	SO	1740 N	20 mm	0.6 Bar	-
S34	SC	16100 N	33.5 mm	-	3.2 Bar
	SO	-	-	-	-

SELECTION OF LINEAR PNEUMATIC ACTUATORS

Valve size DN	Valve type	MAX P1 Inlet Pressure	Pneumatic actuator type
15	L1S, L1SB, M1F, M1FBN, G1F, G1FBN, H1F, H1FBN	16	S16
20	L2S, M1FBN, M2F, G1FBN, G2F, H1FBN, H2F	16	S16
	L1S, L1SB, L3S	10	
	M1F, G1F, H1F	7,5	
25	L1SB, L2S, M1FBN, M2F, G1FBN, G2F, G1FB, H1FBN, H2F, H1FB	16	S16
	M1F, G1F, H1F	5	
32	L1SB, L2S, G1FBN, G2F, H1FBN, H2F, M1FBN, M2F	16	S16
	L3S, M3F, G3F, H3F	10	
40	L2S, G2F, M2F, H2F	16	S16
	M1FBN, G1FBN, H1FBN	10	
	M3F, G3F, H3F	7,5	
	L3S	5	
50	L2S, G2F, M2F, H2F	16	S16
	M1FBN, G1FBN, H1FBN	16	
	L3S, M3F, G3F, H3F	16	
65	L3F, M1FBN, M2F, M3F, G1FBN, G2F, G3F, H1FBN, H2F	16	S25
80	L3F, M1FBN, M2F, M3F, G1FBN, G2F, G3F, H1FBN, H2F	16	S25
100	L3F, M2F, M3F, G2F, G3F, H2F	16	S25
125	L3F, M2F, M3F, G2F, G3F, H2F	16	S25
150	L3F, M2F, M3F, G2F, G3F, H2F	16	S25
200	L3F, M3F, G3F	16	S34
250	L3F, M3F, G3F	10	S34
300	L3F, M3F, G3F	10	S34 (on request)

Where the differential pressure is higher than noted S16 must be replaced with S25.

Where manual override is needed S16 must be replaced with S25

Pneumatic actuators type VT Single Acting

For 2 & 3-way valves type G/L/M/S 2FM-T & G/L/M/S 3FM-T

0-6.5.15

Page 1 of 4



APPLICATIONS

Pneumatic actuators type VT and are the main component of the automatic control system.

It is mainly used for rotary angle 90° to open and close the rotary Clorius valves.

Single-acting cylinders use one air port to allow compressed air to enter the cylinder to move the piston to the desired position, as well as an internal spring to return the piston to the "home" position when the air pressure is removed.

Actuators can work with SPRING OPEN or SPRING CLOSE functions Pneumatic actuators type VT has cooperated with manual override type KH or mounted directly on the valve.

VT actuators are made in accordance with the latest international standards and higher efficiency and reliability

QUALITY

Products manufactured acc. to ISO9001 standard.

Each individual actuator has been factory inspected and tested and given a serial number for full traceability.

A single compact design utilising identical body and end caps for both - double and single acting.

Full conformance to following latest specifications: ISO 5211, DIN 3337 and VDI/VDE 3845 for products interchangeability and easy mounting of solenoids, limit switches and other accessories.

TECHNICAL DATA

Materials:

Cap	Aluminum alloy
Piston	Aluminum alloy
Drive shaft	Alloy Steel
Nut	Stainless steel
Washer	Stainless steel
Spring clip	Spring steel
Position indicator	Nylon
Indicator thrust bearing	Stainless steel
Bearing	POM+PTFE
Wear band	Nylon
Spring seat	Nylon
"o" ring	NBR
Spring	High-carbon steel

FEATURES

- **VT series pneumatic actuators have an advantageous characteristic in:**
 - Reliability
 - High performance
- **Extensive products range allows the best versatility**
- **Compact and light**
- **VT piston rack and pinion design for compact construction, symmetric mounting position, high-cycle life and fast operation.**
- **Two independent external travel stop adjustments permit easy and precise adjustment of +/- 5° In both directions.**
- **This adjustment may be made in either the open or closed position and provides for accurate valve.**
- **Multiple bearings and guides on pistons and racks for precise operation, low friction, high cycle life and a blowout proof pinion shaft.**
- **Electroless nickel- plated blowout resistant, bearing guided, one-piece pinion shaft for improved safety and maximum cycle life.**
- **High precision teeth on piston racks and pinion shaft for accurate positioning, low backlash, and maximum engagement resulting in overall efficient operation.**
- **Extruded aluminium body with both internal and external corrosion protections having a honed cylinder surface for longer life and a lower coefficient of friction.**
- **Selected high-quality bearings and seals that provide a wide operating temperature range, low friction, and high cycle life.**
- **Multifunctional position indicator for visual position indication, and a direct, easy, economical way to mount popular sensor.**
- **Protection class in IP65**

Subject to change without notice.

**RECOMMENDED PNEUMATIC ACTUATORS TYPES SINGLE ACTING
 AND CLORIUS ROTARY VALVES AND DECLUTCH**

DN	Type	Drop pressure (P1 ≤ ...bar)	Pneumatic Actuator for DP 5 bar	DECLUTCH
65	G3FM-T	25	VT125S	KH-3
65	G3FM-TM	25	VT125S	KH-3
80	G3FM-T	25	VT125S	KH-3
80	G3FM-TM	25	VT140S	KH-4
100	G3FM-T	25	VT160S	KH-4
100	G3FM-TM	25	VT160S	KH-4
125	G3FM-T	25	VT190S	KH-5
125	G3FM-TM	25	VT190S	KH-5
150	G3FM-T	16	VT190S	KH-5
150	G3FM-TM	16	VT190S	KH-5
200	G3FM-T	16	VT210S	KH-5
200	G3FM-TM	16	VT240S	KH-6
250	G3FM-T	16	VT240S	KH-6
250	G3FM-TM	16	VT270S	KH-6
300	G3FM-T	16	VT270S	KH-6
300	G3FM-TM	16	VT300S	KH-7
350	G3FM-T	10	VT300S	KH-7
350	G3FM-TM	10	VT350S	KH-8
400	G3FM-T	10	VT350S	KH-8
400	G3FM-TM	10	VT400S	KH-9
450	G3FM-T	10	VT400S	KH-9
450	G3FM-TM	10	VT400S	KH-9
500	G3FM-T	10	VT400S	KH-9
500	G3FM-TM	10	Available on request	
600	G3FM-T	10	Available on request	
600	G3FM-TM	10	Available on request	

DIMENSION SKETCH

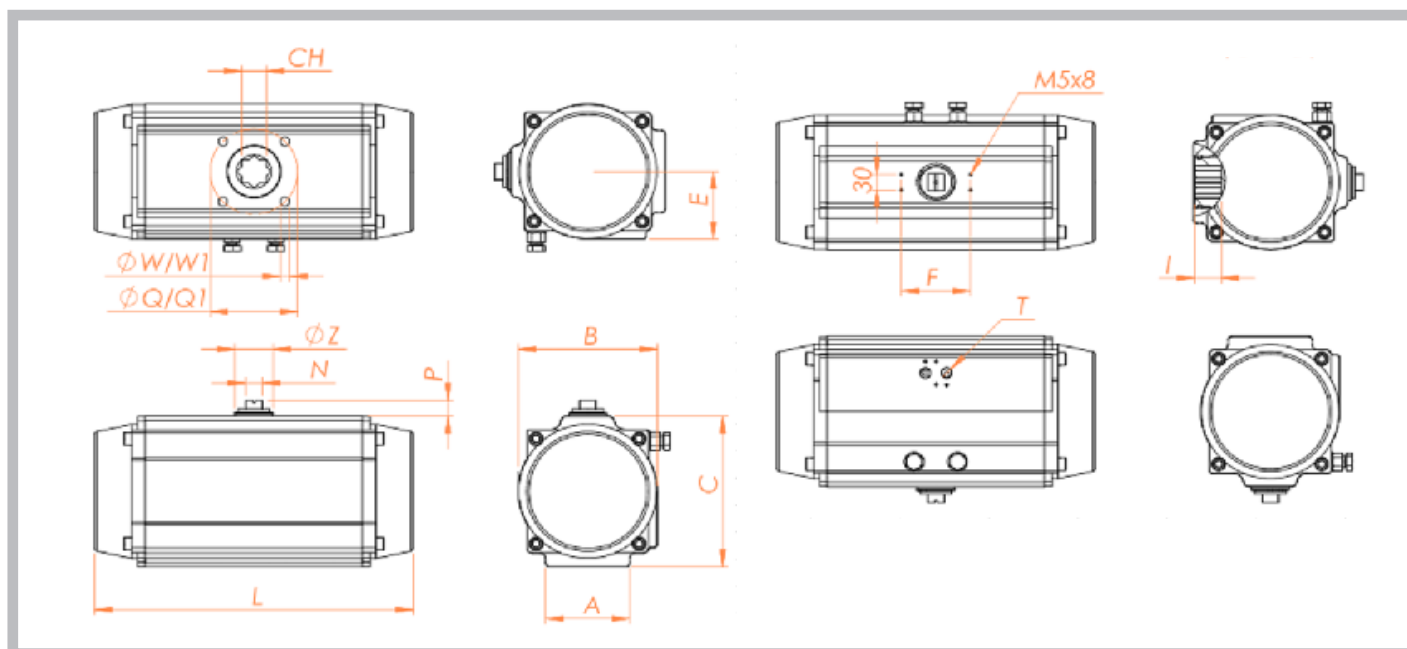

MODEL	A	B	C	D	E	F	P	ØZ	N	I	FLANGE	Q	Q1	W	W1	Ch	T	Weight [kg]
VT125S	96	157	161	337	85	80	30	56	22	25	F07/10	70	102	M8x12	M10x15	22x22	G1/4'	12.5
VT140S	110	178	178	377	97	80	30	56	22	31	F10/12	102	125	M10x15	M12x18	27x27	G1/4'	15.9
VT160S	112	196	200	412	106	130	30	56	22	31	F10/12	102	125	M10x15	M12x18	27x27	G1/4'	23.8
VT190S	136	216.5	232	488	112	130	30	56	22	41	F10/14	102	140	M10x15	M16x24	36x36	G1/4'	33.8
VT210S	140	235.5	255	550	120	130	30	80	32	40	F14	-	140	-	M16x24	36x36	G1/4'	48.4
VT240S	159	262	292	602	131	130	30	80	32	50	F16	-	165	-	M20x28	46x46	G1/2'	77.8
VT270S	159	295	331	672	147.5	130	30	80	32	50	F16	-	165	-	M20x28	46x46	G1/2'	90.6
VT300S	180	335	354	784	173	130	30	80	32	50	F16	-	165	-	M20x28	46x46	G1/2'	135.6
VT350S	270	385	410	845	195	130	30	80	32	50	F16/F25	165	254	M20x28	M16x30	46x46	G1/2'	188.1
VT400S	290	520	466	956	260	130	30	80	32	60	F25	-	254	-	M16x30	55x55	G1/2'	283.5

Other relevant data sheets for VT actuators:

- 2-way valves
- 3-way valves
- Positioners
- Filter regulators
- Controller
- Sensor PT 100
- Pneumatic controller S80

G2FM-T 0.2.5.05.01
G3FM-T 0.2.6.02, 0.2.6.03
0.6.6.01, 0.6.6.02
0.6.8.01
ER2022 0.4.6.02
0.4.7.25
0.6.7.01

Pneumatic actuators type VT Double Acting

For 2 & 3-way valves type G/L/M/S 2FM-T & G/L/M/S 3FM-T

0-6.5.16

Page 1 of 4



APPLICATIONS

Pneumatic actuators type VT and are the main component of the automatic control system.

It is mainly used for rotary angle 90° to open and close the rotary Clorius valves.

Double-acting cylinders have an air port at each end and move the piston forward and back by alternating the port that receives the high-pressure air.

Pneumatic actuators type VT has cooperated with manual override type KH or mounted directly on the valve.

VT actuators are made in accordance with the latest international standards and higher efficiency and reliability.

QUALITY

Products manufactured acc. to ISO9001 standard.

Each individual actuator has been factory inspected and tested and given a serial number for full traceability.

A single compact design utilising identical body and end caps for both - double and single acting.

Full conformance to following latest specifications: ISO 5211, DIN 3337 and VDI/VDE 3845 for products interchangeability and easy mounting of solenoids, limit switches and other accessories.

TECHNICAL DATA

Materials:

Body	Aluminum alloy
Cap	Aluminum alloy
Drive shaft	Alloy Steel
Nut	Stainless steel
Washer	Stainless steel
Position indicator	Nylon
Indicator thrust bearing	Stainless steel
Bearing	POM+PTFE
Wear band	Nylon
Spring seat	Nylon
"o" ring	NBR

FEATURES

- VT series pneumatic actuators have an advantageous characteristic in:
 - Reliability
 - High performance
- Extensive products range allows the best versatility
- Compact and light
- VT piston rack and pinion design for compact construction, symmetric mounting position, high-cycle life and fast operation.
- Two independent external travel stop adjustments permit easy and precise adjustment of +/- 5° In both directions.
- This adjustment may be made in either the open or closed position and provides for accurate valve.
- Multiple bearings and guides on pistons and racks for precise operation, low friction, high cycle life and a blowout proof pinion shaft.
- Electroless nickel- plated blowout resistant, bearing guided, one-piece pinion shaft for improved safety and maximum cycle life.
- High precision teeth on piston racks and pinion shaft for accurate positioning, low backlash, and maximum engagement resulting in overall efficient operation.
- Extruded aluminium body with both internal and external corrosion protections having a honed cylinder surface for longer life and a lower coefficient of friction.
- Selected high-quality bearings and seals that provide a wide operating temperature range, low friction, and high cycle life.
- Multifunctional position indicator for visual position indication, and a direct, easy, economical way to mount popular sensor.
- Protection class in IP65

Subject to change without notice.

**RECOMMENDED PNEUMATIC ACTUATORS TYPES DOUBLE ACTING
 AND CLORIUS ROTARY VALVES AND DECLUTCH**

DN	Type	Drop pressure (P1 ≤ ...bar)	Pneumatic Actuator for DP 5 bar	DECLUTCH
65	G3FM-T	25	VT085D	KH-1
65	G3FM-TM	25	VT095D	KH-2
80	G3FM-T	25	VT095D	KH-2
80	G3FM-TM	25	VT095D	KH-2
100	G3FM-T	25	VT110D	KH-2
100	G3FM-TM	25	VT125D	KH-3
125	G3FM-T	25	VT125D	KH-3
125	G3FM-TM	25	VT140D	KH-3
150	G3FM-T	16	VT125D	KH-3
150	G3FM-TM	16	VT140D	KH-3
200	G3FM-T	16	VT160D	KH-4
200	G3FM-TM	16	VT190D	KH-4
250	G3FM-T	16	VT190D	KH-4
250	G3FM-TM	16	VT210D	KH-5
300	G3FM-T	16	VT210D	KH-5
300	G3FM-TM	16	VT240D	KH-5
350	G3FM-T	10	VT240D	KH-5
350	G3FM-TM	10	VT240D	KH-5
400	G3FM-T	10	VT240D	KH-5
400	G3FM-TM	10	VT270D	KH-6
450	G3FM-T	10	VT270D	KH-6
450	G3FM-TM	10	VT300D	KH-6
500	G3FM-T	10	VT270D	KH-6
500	G3FM-TM	10	Available on request	
600	G3FM-T	10	VT350D	KH-7
600	G3FM-TM	10	Available on request	

Pneumatic actuators type VT Double Acting

For 2 & 3-way valves type G/L/M/S 2FM-T & G/L/M/S 3FM-T

0-6.5.16

Page 3 of 4

DIMENSION SKETCH

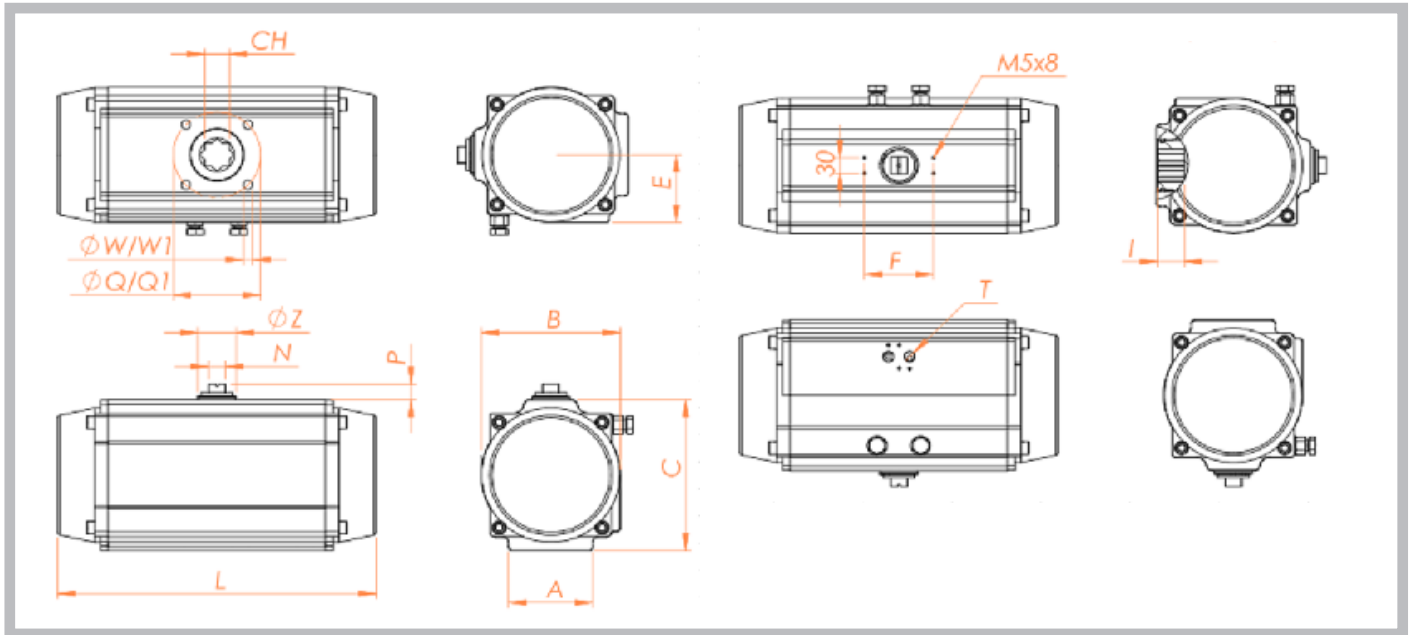

MODEL	A	B	C	D	E	F	P	ØZ	N	I	FLANGE	Q	Q1	W	W1	Ch	T	Weight [kg]
VT085D	68	112.5	113	229	63.5	80	20	40	14	19	F 05/07	50	70	M6x9	M8x12	17x17	G1/4'	3.8
VT095D	92	126	123	264	71	80	20	40	14	19	F05/07	50	70	M6x9	M8x12	17x17	G1/4'	5.1
VT110D	93	138.5	136	266	76.5	80	20	40	14	19	F07/10	70	102	M8x12	M10x15	17x17	G1/4'	6.1
VT125D	96	157	161	337	85	80	30	56	22	25	F07/10	70	102	M8x12	M10x15	22x22	G1/4'	10.9
VT140D	110	178	178	377	97	80	30	56	22	31	F10/12	102	125	M10x15	M12x18	27x27	G1/4'	13.8
VT160D	112	196	200	412	106	130	30	56	22	31	F10/12	102	125	M10x15	M12x18	27x27	G1/4'	20.2
VT190D	136	216.5	232	488	112	130	30	56	22	41	F10/14	102	140	M10x15	M16x24	36x36	G1/4'	28.4
VT210D	140	235.5	255	550	120	130	30	80	32	40	F14	-	140	-	M16x24	36x36	G1/4'	40.0
VT240D	159	262	292	602	131	130	30	80	32	50	F16	-	165	-	M20x28	46x46	G1/2'	52.6
VT270D	159	295	331	672	147.5	130	30	80	32	50	F16	-	165	-	M20x28	46x46	G1/2'	73.6
VT300D	180	335	354	784	173	130	30	80	32	50	F16	-	165	-	M20x28	46x46	G1/2'	108.0
VT350D	270	385	410	845	195	130	30	80	32	50	F16/ F25	165	254	M20x28	M16x30	46x46	G1/2'	146.7

Other relevant data sheets for VT actuators:

- 2-way valves
- 3-way valves
- Positioners
- Filter regulators
- Controller
- Sensor PT 100
- Pneumatic controller S80

G2FM-T 0.2.5.05.01
G3FM-T 0.2.6.02, 0.2.6.03
0.6.6.01, 0.6.6.02
0.6.8.01
ER2022 0.4.6.02
0.4.25.01
0.6.7.01

**RUGGET, EASY MAINTENANCE
& PRECISE CALIBRATION**

Rugged valve control device giving a confidence in reliable performance and outstanding durability under harsh working conditions.



PNEUMATIC CONTROLLERS & POSITIONERS

6

OUR PNEUMATIC CONTROLLERS AND POSITIONER PROGRAM INCLUDES:

POSITIONER TYPE

PNEUMATIC-PNEUMATIC
ELECTRO-PNEUMATIC

CONTROLLER TYPE

PNEUMATIC INDICATING CONTROLLER

FILTER REGULATOR

FLOAT TYPE WITH AUTO-DRAIN

POSITIONER MODEL

PPL, PPR
EPL, EPR

CONTROLLER MODEL

S80

REGULATOR MODEL

AW 20K-F02CE-H

PPL / PPR

Pneumatic-Pneumatic Positioner

0-6.6.01-C

Page 1 of 4

PPL

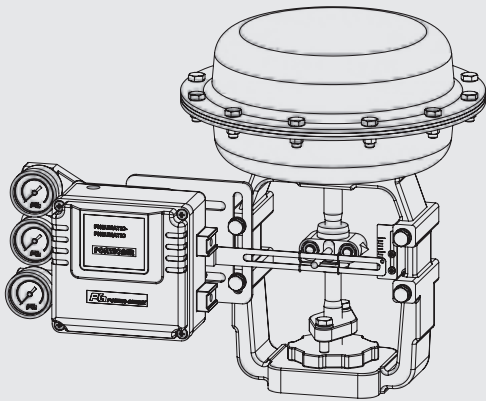

Robust valve control device giving a confidence in reliable performance and outstanding durability under harsh working environments

FEATURES

- Easy maintenance
- Precise calibration with simple **SPAN** and **ZERO** adjustments
- Simple conversion to direct acting or reverse acting
- 1/2 split range available
- Rugged aluminum housing with corrosion-resistant coating
- Vibration resistant design
- Stainless steel gauges standard
- Restricted pilot valve orifice kit for small actuators included

OPTIONS

- High temperature

SPECIFICATIONS

	PPL	
	Linear Type (Lever Feedback) Single	Double
Input Signal	0.2-1.0 bar (3-15 psi) (Note 1,2)	
Supply Air Pressure	Max 7.0 bar (100 psi)	
Standard Stroke	10-80 mm (Note.3)	
Pneumatic Connections	PT(Rc) 1/4 or NPT 1/4	
Ambient Temperature	-20~ +70 °C (Note. 4)	
Pressure Gauge	Stainless steel	
Output Characteristics	Linear	
Linearity	Within ±1.0% F.S.	Within ±1.5% F.S.
Sensitivity	Within ±0.2% F.S.	Within ±0.5% F.S.
Hysteresis	Within ±1.0% F.S.	
Repeatability	Within ±0.5% F.S.	
Air Consumption	5 LPM (Sup. 1.4 bar)	
Flow Capacity	80 LPM (Sup. 1.4 bar)	
Body Material	Aluminium die-cast	
Weight	2.1 kg	

Note:

- 1) 1/2 split range is available for 3-9 psi input signal or 9-15 psi input signal
- 2) Please contact for 6-30 psi input signal
- 3) Feedback lever can be extended to stroke 80-150mm
- 4) High temperature option: up to +120°C

HOW TO ORDER

PPL — Feedback Lever Pressure Gauge Pilot Valve Orifice Connection Threads Operating Temperature Mounting Bracket

Description	Code	Description	Code
Feedback Lever:	A: Stroke 10 ~ 40mm B: Stroke 10 ~ 80mm C: Stroke 80 ~ 150mm	Connection Threads: (pneumatic)	3: PT(Rc) ¼ 4: NPT ¼
Pressure Gauge	1: 6 bar (90psi) 2: 10 bar (150psi)	Operating Temperature:	T: 70°C (standard) H: 120°C L: -40°C
Pilot Valve Orifice:	S: Standard (Actuator volume over 180 cm³) M: Small orifice (Ø 1.0 or Ø0.7) (Actuator volume 90~180cm³)	Mounting Bracket:	L: DIN/IEC 60534-6-1

DIMENSION SKETCH

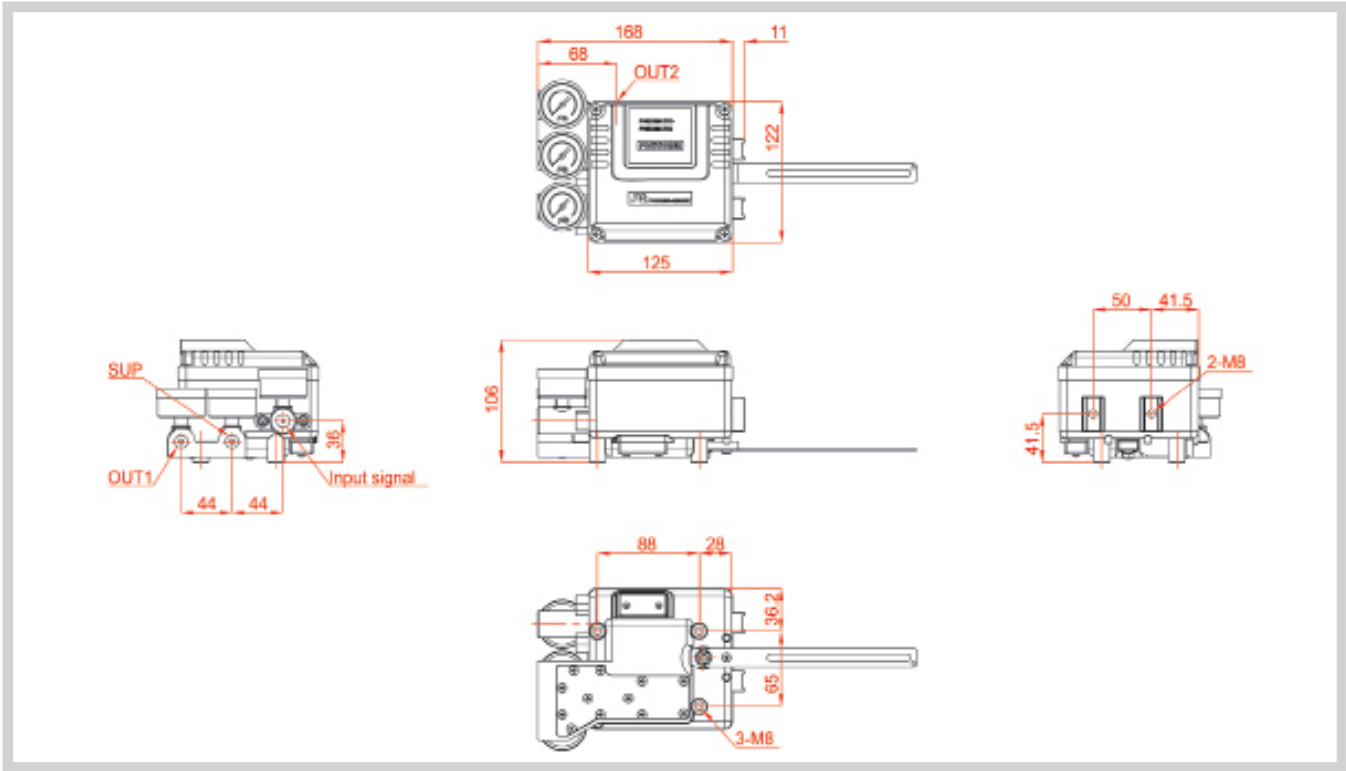

PPR



With Dome Indicator



Robust valve control device giving a confidence in reliable performance and outstanding durability under harsh working environments

FEATURES

- Easy maintenance
- Precise calibration with simple **SPAN** and **ZERO** adjustments
- Simple conversion to direct acting or reverse acting
- 1/2 split range available
- Rugged aluminum housing with corrosion-resistant coating
- Vibration resistant design
- Stainless steel gauges standard
- Restricted pilot valve orifice kit for small actuators included

OPTIONS

- Position transmitter (4-20mA output signal)
- 2 x SPDT limit switch
- 2 x P&F proximity sensor NJ2-V3-N
- Visual dome indicator
- High temperature

SPECIFICATIONS

	PPR	
	Linear Type (Lever Feedback)	
	Single	Double
Input Signal	0.2-1.0 bar (3-15 psi) (Note 1,2)	
Supply Air Pressure	Max 7.0 bar (100 psi)	
Standard Stroke	60-100° (Note.3)	
Pneumatic Connections	PT(Rc) 1/4 or NPT 1/4	
Ambient Temperature	-20~ +70 °C (Note. 4)	
Pressure Gauge	Stainless steel	
Output Characteristics	Linear	
Linearity	Within ±1.0% F.S.	Within ±1.5% F.S.
Sensitivity	Within ±0.5% F.S.	
Hysteresis	Within ±1.0% F.S.	
Repeatability	Within ±0.5% F.S.	
Air Consumption	5 LPM (Sup. 1.4 bar)	
Flow Capacity	80 LPM (Sup. 1.4 bar)	
Body Material	Aluminium die-cast	
Weight	2.5 kg	

Note:

- 1) 1/2 split range is available for 3-9 psi input signal or 9-15 psi input signal
- 2) Please contact for 6-30 psi input signal
- 3) Operating angle can be adjusted to 0-60° or 0-100°
- 4) High temperature option: up to +120°C without feedback options
up to +85°C with feedback options

HOW TO ORDER

PPR	Feedback Lever	Pressure Gauge	Pilot Valve Orifice	Position Feedback	Connection Threads	Dome Indicator	Operating Temperature	Mounting Bracket

Description	Code
Feedback Lever:	A: NAMUR shaft (direct mounting) B: Fork lever M6 x 40L C: Fork lever other size on request
Pressure Gauge	1: 6 bar (90psi) 2: 10 bar (150psi)
Pilot Valve Orifice:	S: Standard (Actuator volume over 180 cm ³) M: Small orifice (Ø 1.0 or Ø0.7)
Position Feedback:	N: None (standard) O: Position transmitter (4~20mA output signal) L: 2 x SPDT limit switch P: 2 x proximity sensor P&F NJ2-V3-N M: O + L Q: O + P

Description	Code
Connection Threads:	3: PT(Rc) ¼ (pneumatic) 4: NPT ¼
Dome Indicator:	N: Flat indicator (standard)
Operating Temperature:	T: 70°C (standard) H: 120°C (without position feedback option) 85°C (with position feedback option)
Mounting Bracket	
- NAMUR Shaft Type:	R: Multi-size NAMUR bracket for DIN VDI/VDE 3845 (130 x 30 x 50 bracket on request)
- Fork Lever Type	F: DHCT bracket 80x30 for fork lever type E: Multi-size NAMUR bracket for Fork lever type (130 x 30 x 50 bracket on request)

DIMENSION SKETCH

A. With Flat Indicator

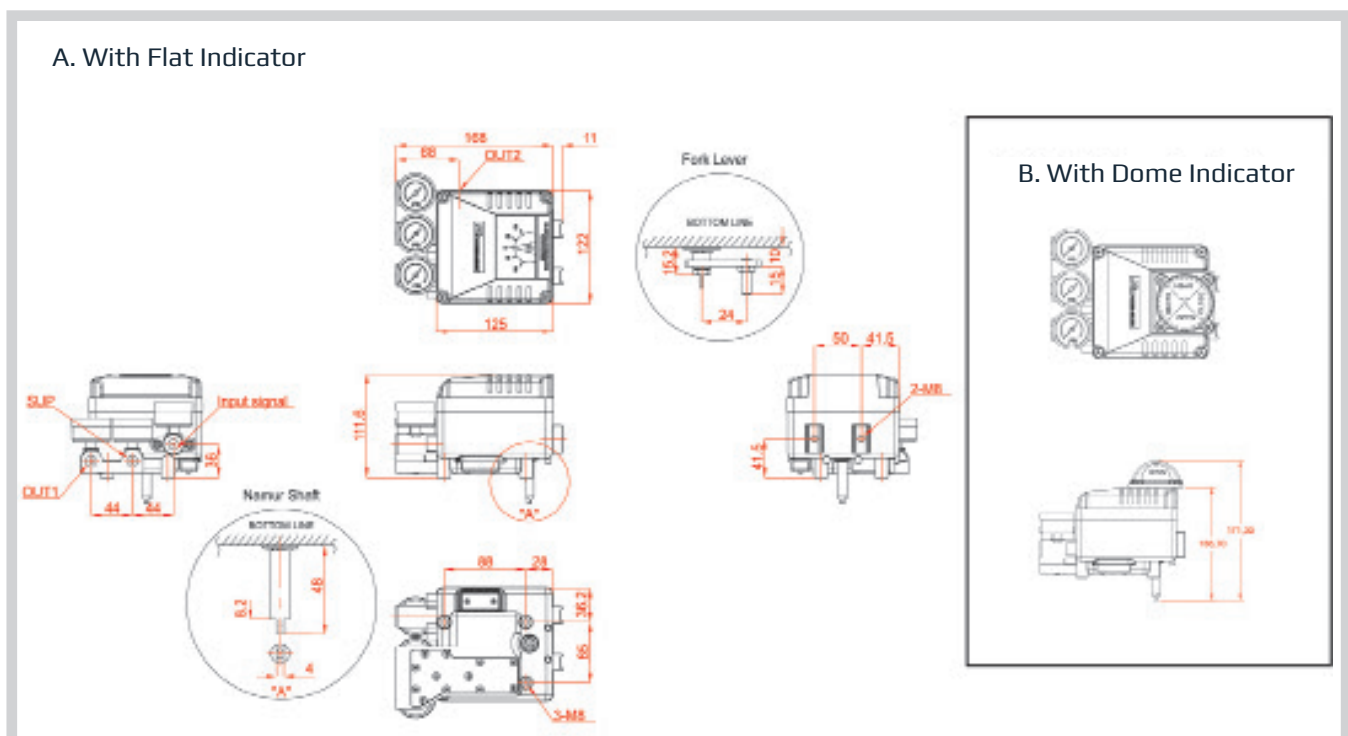

6

EPL / EPR

Electro-Pneumatic Positioner

0-6.6.02-E

Page 1 of 8

EPL

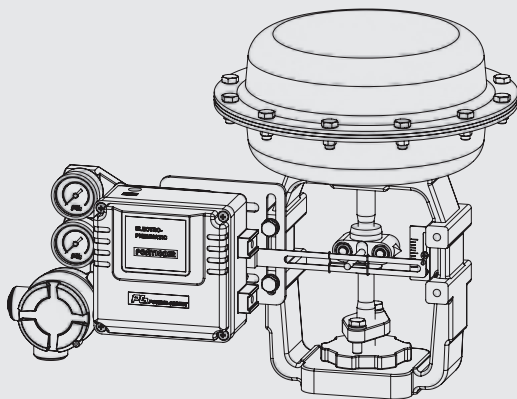

Robust valve control device giving a confidence in reliable performance and outstanding durability under harsh working environments

FEATURES for EPL

- Easy maintenance
- Precise calibration with simple SPAN and ZERO adjustments
- Simple conversion to direct acting or reverse acting
- 1/2 split range available
- Rugged aluminum housing with corrosion-resistant coating
- Vibration resistant design
- Stainless steel gauges standard
- Restricted pilot valve orifice kit for small actuators included
- KC-certified flameproof Ex dmb IIB+H₂ T6
- NEPSI-certified flameproof Ex dmb IIB+H₂ T6
- IECEx-certified flameproof Ex dmb IIC T6/T5
- ATEX-certified flameproof Ex dmb IIC T6/T5
- KC-certified flameproof Ex dmb IIC T6/T5
- IECEx-certified intrinsically safe Ex ia IIC T6
- ATEX-certified intrinsically safe Ex ia IIC T6
- KC-certified intrinsically safe Ex ia IIC T6

OPTIONS

- Position transmitter (4...20 mA output signal)
- High temperature (+120°C)
- Low temperature (-40°C)

SPECIFICATIONS

	EPL	
	Linear Type (Lever Feedback)	
	Single	Double
Input Signal	4-20mA DC (Note. 1)	
Input Resistance	235 ± 15Ω	
Air Supply	Max 7.0 bar (100 psi) free of oil, water and mois-	
Standard Stroke	10-80 mm (Note. 2)	
Pneumatic Connections	PT(Rc) 1/4 or NPT 1/4	
Electrical Connections	PF (G) ½ or NPT ½	
Protection Class	Ex dmb IIB+H ₂ T6/ Ex dmb IIC T6/T5 Ex ia IIC T6/	
Ambient Temperature	-20~ +70 °C (Note. 3)	
Pressure Gauge	Stainless steel	
Output Characteristics	Linear	
Linearity	Within ±1.0% F.S.	Within ±1.5% F.S.
Sensitivity	Within ±0.2% F.S.	Within ±0.5% F.S.
Hysteresis	Within ±1.0% F.S.	
Repeatability	Within ±0.5% F.S.	
Air Consumption	5 LPM (Sup. 1.4 bar)	
Flow Capacity	80 LPM (Sup. 1.4 bar)	
Body Material	Aluminium die-cast	
Weight	3.3 kg (with terminal box)	

Note:

- 1) 1/2 split range is available for 4-12mA input signal or 12-20mA input signal
- 2) Feedback lever can be extended to stroke 80-150mm
- 3) Temperature option: up to +120°C without feedback options
up to +85°C without feedback options
up to -40°C without feedback options

MOUNTING

1. Install the EPL positioner so that the angle between the valve stem and the feedback lever can be 90° at 12 mA input signal (50%) as shown to the right.
2. The operating angle of the EPL feedback lever is minimum 10° to maximum 30° .

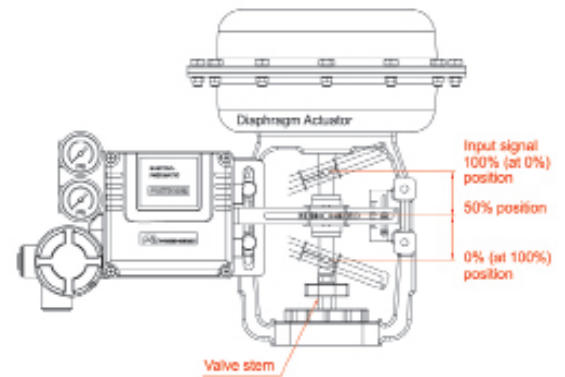

INTERNAL VIEW

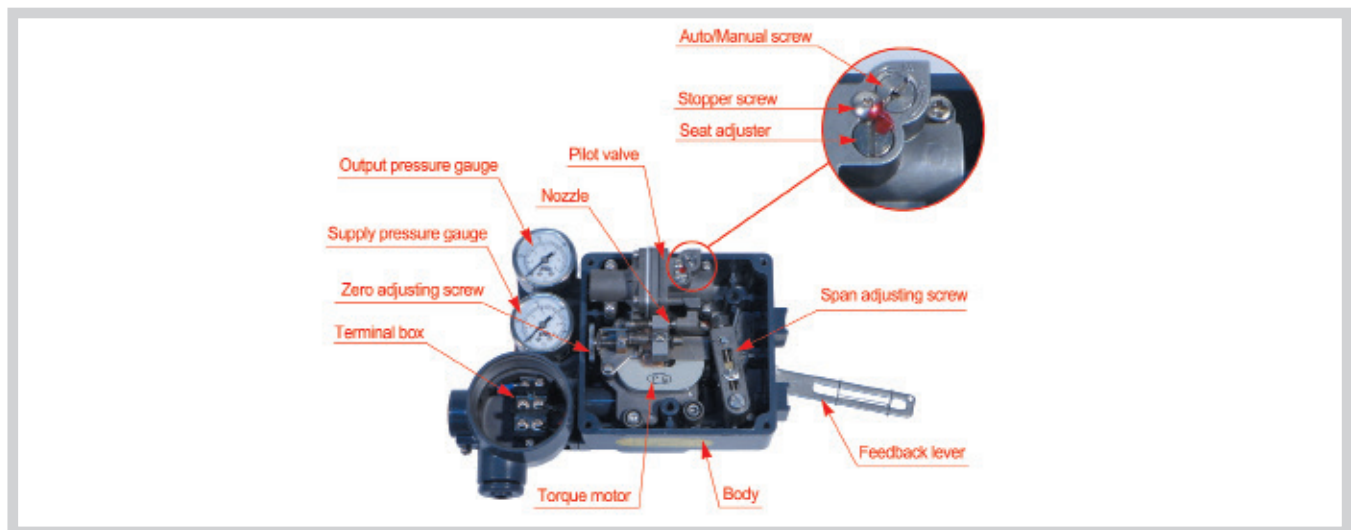

AIR CONNECTIONS

Direct Acting (DA)

As the input increases,
Valve stem moves downwards
Actuator: **DA**
Connection: out 1

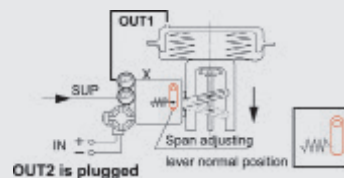

As the input increases,
Valve stem moves downwards
Actuator: **DA**
Connection: out 2

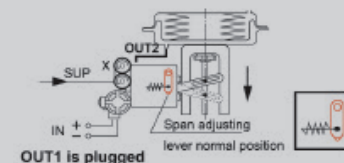

As the input increases,
Valve stem moves downwards

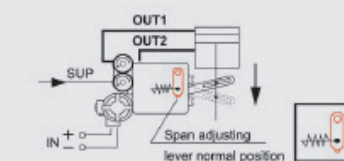

Reverse Acting (RA)

As the input increases,
Valve stem moves upwards
Actuator: **RA**
Connection: out 2

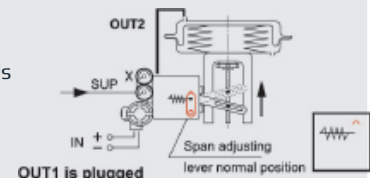

As the input increases,
Valve stem moves upwards
Actuator: **RA**
Connection: out 1

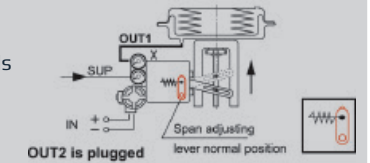

As the input increases,
Valve stem moves upwards

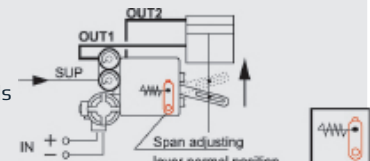

POSITION TRANSMITTER OPTIONS (BUILT-IN TYPE)

1. Board View

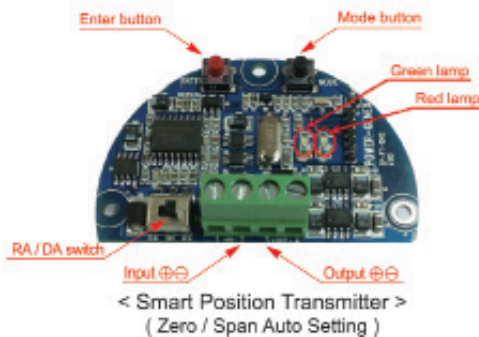
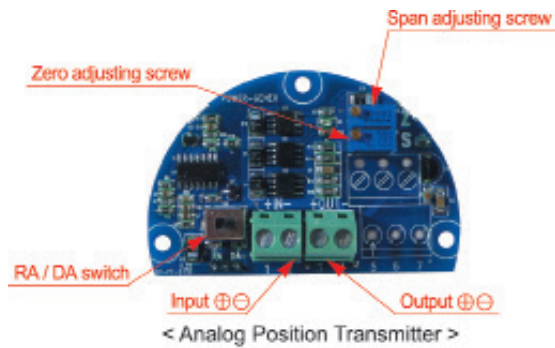

3. Wiring Diagram

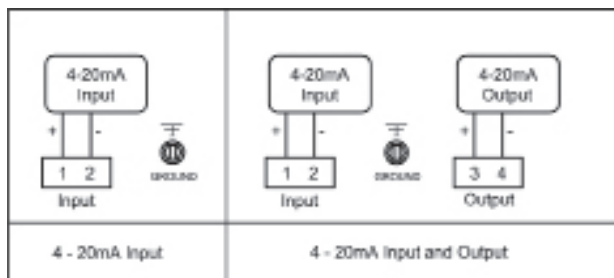

2. Position Transmitter (4-20mA output signal)

a. Specifications

Power Supply Rating	5.5-30 VDC loop power
Recommended Power Supply	24 VDC
Output Signal	4-20 mA, 2-wire
Operating Temperature	-20°C ~ +85°C
Load Impedance	0 ~ 600 ohms
Max. Output	30 mA DC
Linearity	± 1.0 %
Hysteresis	1.0 % of full scale
Repeatability	±0.5 % of full scale
Adjustment	Zero and Span in terminal box

b. with mA calibrator

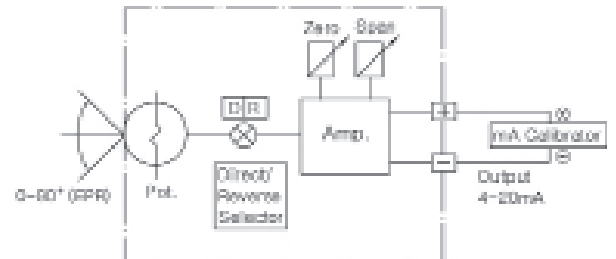

c. with multimeter

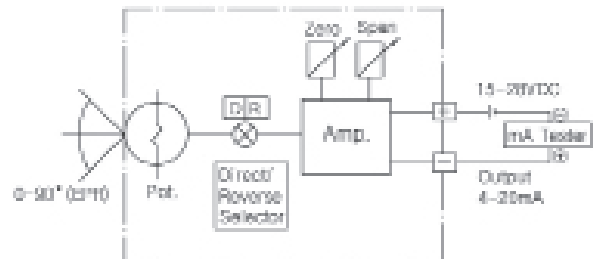

APPLICATION FOR LIMIT SWITCHES (EXTERNAL TYPE)

1) With explosion proof PTP-L

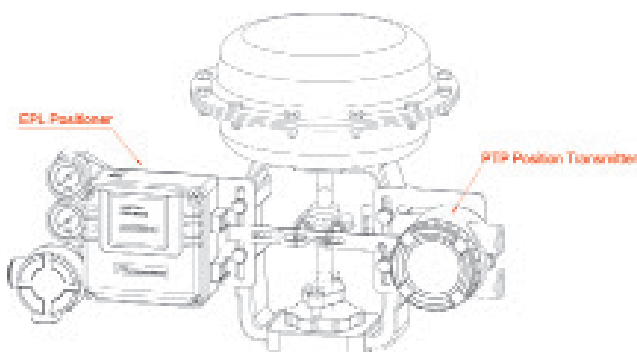

2) With non-explosion proof LSB-200

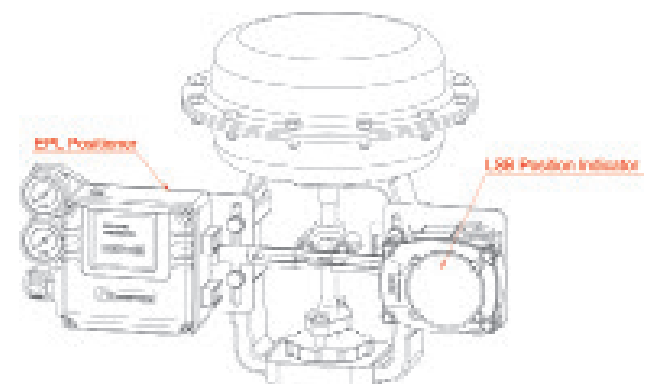

HOW TO ORDER

EPL —

Protection Class	Feedback Lever	Pressure Gauge (SUP, OUT)	Pilot Valve Orifice	Position Feedback	Connection Threads	Operating Temp.	Mounting Bracket
------------------	----------------	---------------------------	---------------------	-------------------	--------------------	-----------------	------------------

Description	Code	Description	Code
Protection Class:	F: KC flameproof Ex dmb IIB+H ₂ T6 NEPSI flameproof Ex dmb IIB+H ₂ T6 A: KC flameproof Ex dmb IIC T6/T5 D: IECEx flameproof Ex dmb IIC T6 I: IECEx intrinsically safe Ex ia IIC T6 ATEX intrinsically safe Ex ia IIC T6 KC intrinsically safe Ex ia IIC T6	Position Feedback: (only for waterproof type)	N: None (standard) O: Analog position transmitter (4~20mA output signal) S: Smart position transmitter (4~20mA output signal)
Feedback Lever:	A: Stroke 10~40 mm B: Stroke 10~80 mm C: Stroke 80~150 mm	Connection Threads: (pneumatic - electrical)	3: PT(Rc) ¼ - PF(G) ½ (standard) 4: NPT ¼ - NPT ½ 5: PT(Rc) ¼ - M20 x 1.5
Pressure Gauge:	1: 6 bar (90 psi) 2: 10 bar (150 psi)	Operating Temperature: (only for waterproof type)	T: 70°C (standard) H: 120°C (without position feedback option) 85°C (with position feedback option) L: -40°C (without position feedback option) N: None L: IEC 60534-6-1
Pilot Valve Orifice:	S: Standard (Actuator volume over 180 cm ³) M: Small orifice (Ø1.0 or Ø0.7) (Actuator volume over 90~180 cm ³)	Mounting Bracket:	

DIMENSION SKETCH

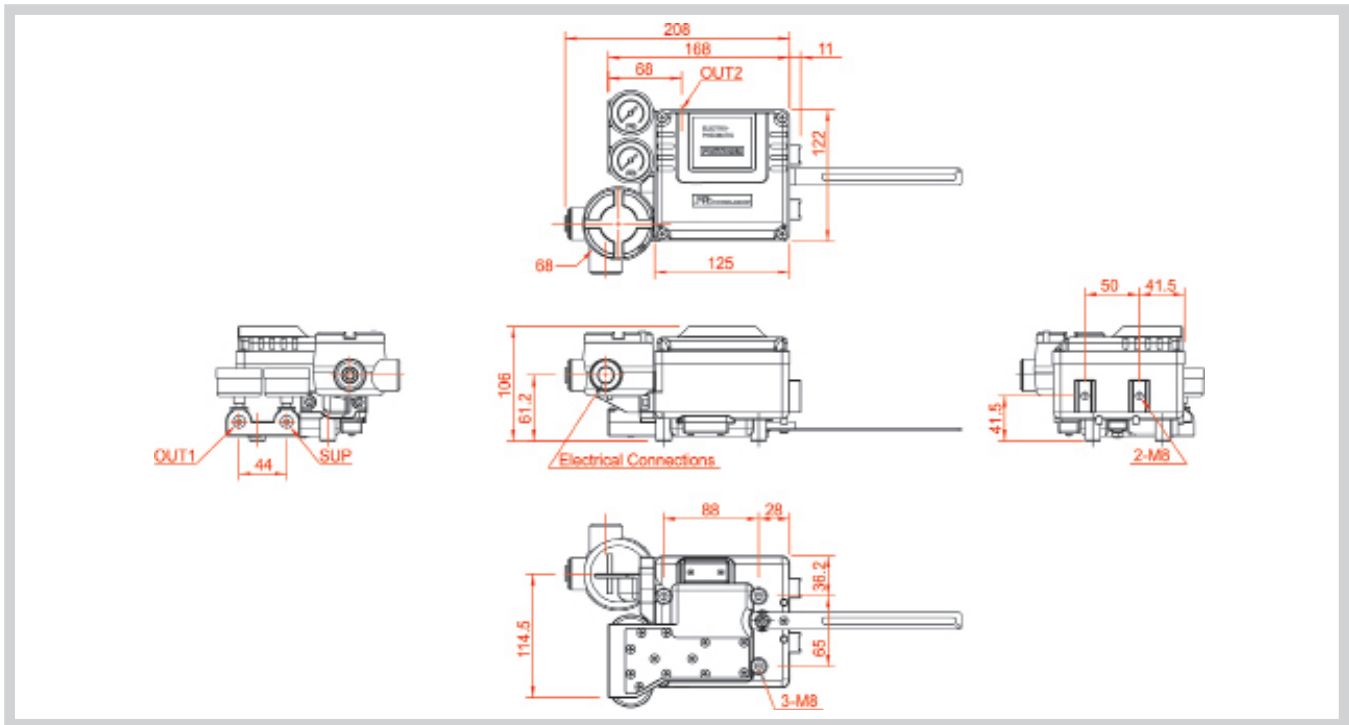

6

EPR



With Dome Indicator

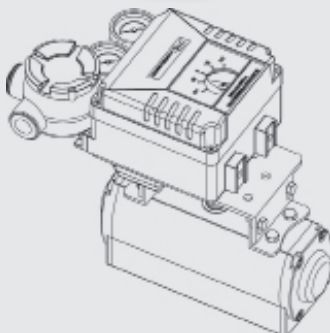

Robust valve control device giving a confidence in reliable performance and outstanding durability under harsh working environments.

OPTIONS

- Position transmitter (4...20 mA output signal)
- 2 x SPDT limit switch
- 2 x P&F proximity sensor NJ2-V3-N
- Visual dome indicator
 - High temperature (+120 °C)
 - Low temperature (-40 °C)

FEATURES for EPR

- Easy maintenance
- Precise calibration with simple SPAN and ZERO adjustments
- Simple conversion to direct acting or reverse acting
- 1/2 split range available
- Rugged aluminum housing with corrosion-resistant coating
- Vibration resistant design
- Stainless steel gauges standard
- Restricted pilot valve orifice kit for small actuators included
- **KC-certified flameproof Ex dmb 11B+H₂ T6**
- **NEPSI-certified flameproof Ex dmb 11B+H₂ T6**
- **IECEx/KC-certified flameproof Ex dmb IIC T6/T5**
- **ATEX/TR-CU-certified flameproof Ex dmb IIC T6/T5**
- **IECEx/KC-certified intrinsically safe Ex ia IIC T6**
- **ATEX/TR-CU-certified intrinsically safe Ex ia IIC T6**

SPECIFICATIONS

	EPR	
	Rotary Type (Cam Feedback)	
	Single	Double
Input Signal	4-20mA DC (Note. 1)	
Input Resistance	235 ± 15Ω	
Air Supply	Max 7.0 bar (100 psi) free of oil, water and	
Operating Angle	60~100° (Note. 2)	
Pneumatic Connections	PT(Rc) 1/4 or NPT 1/4	
Electrical Connections	PF (G) ½ or NPT ½	
Protection Class	Ex dmb IIB+H ₂ T6/ Ex dmb IIC T6/T5 Ex ia IIC	
Ambient Temperature	-20~ +70 °C (Note. 3)	
Pressure Gauge	Stainless steel	
Output Characteristics	Linear	
Linearity	Within ±1.0% F.S.	Within ±1.5% F.S.
Sensitivity	Within ±0.5% F.S.	
Hysteresis	Within ±1.0% F.S.	
Repeatability	Within ±0.5% F.S.	
Air Consumption	5 LPM (Sup. 1.4 bar)	
Flow Capacity	80 LPM (Sup. 1.4 bar)	
Body Material	Aluminium die-cast	
Weight	3.5 kg (with terminal box) 3.2 kg (without terminal box)	

Note:

- 1) 1/2 split range is available for 4-12mA input signal or 12-20mA input signal
- 2) Operating angle can be adjusted to 0~60° or 0~100°
- 3) Temperature option: up to +120°C without feedback options
up to +85°C without feedback options
up to -40°C without feedback options

MOUNTING

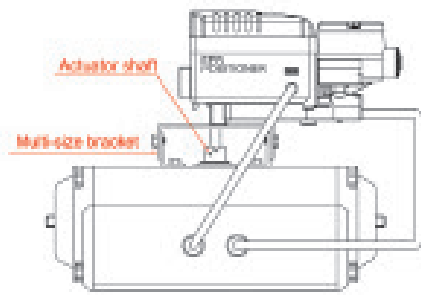

NAMUR Type Mounting

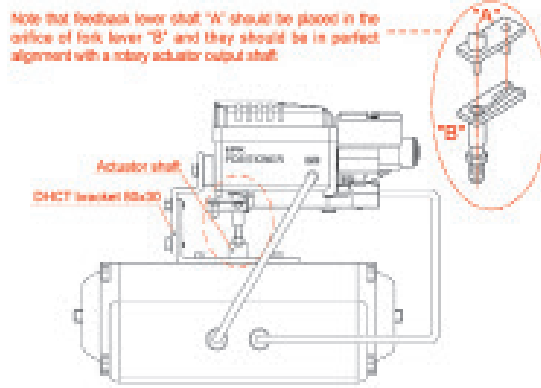

Fork Lever Type Mounting

INTERNAL VIEW

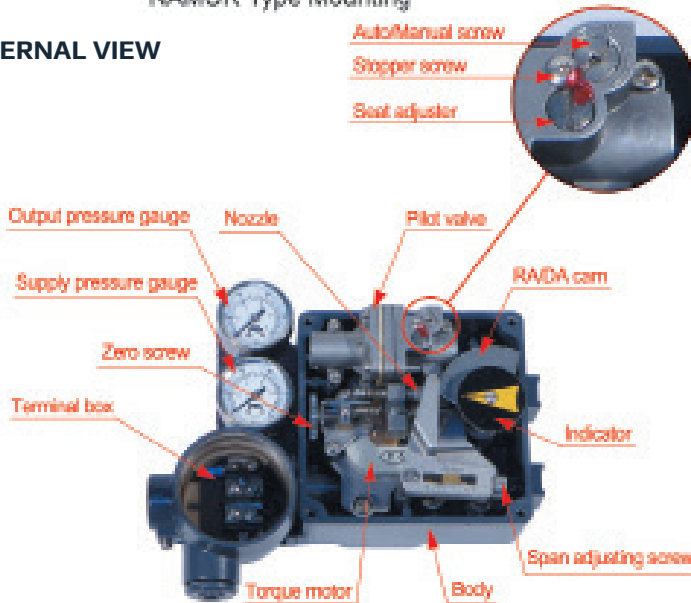

MULTI-SIZE BRACKET

Type	H
80 x 30 x 20H	41
80 x 30 x 30H	51
130 x 30 x 20H	41
130 x 30 x 30H	51
130 x 30 x 50H	71

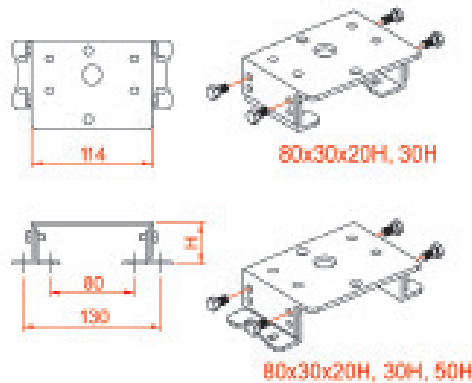

AIR CONNECTIONS

Direct Acting (DA)

As the input increases, Actuator stem rotates clockwise.

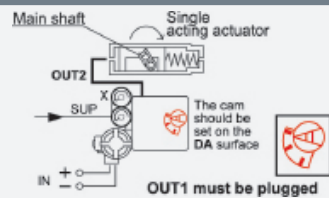

As the input increases, Actuator stem rotates clockwise.

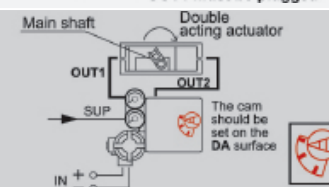

Reverse Acting (RA)

As the input signal increases, Actuator stem rotates counter clockwise.

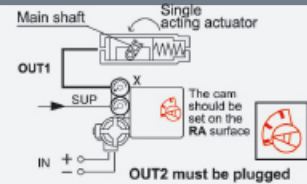

As the input signal increases, Actuator stem rotates counter clockwise.

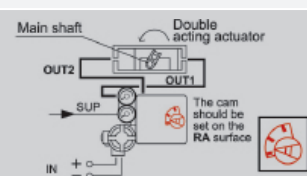

POSITION TRANSMITTER OPTIONS (BUILT-IN TYPE)

1. Board View

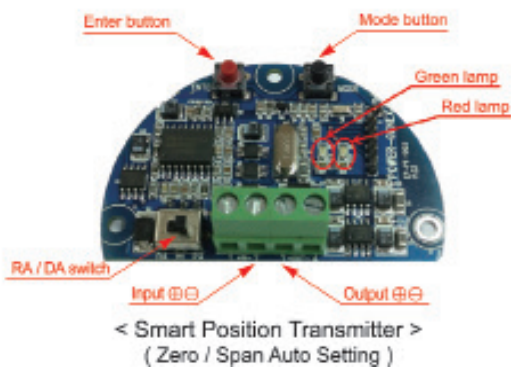
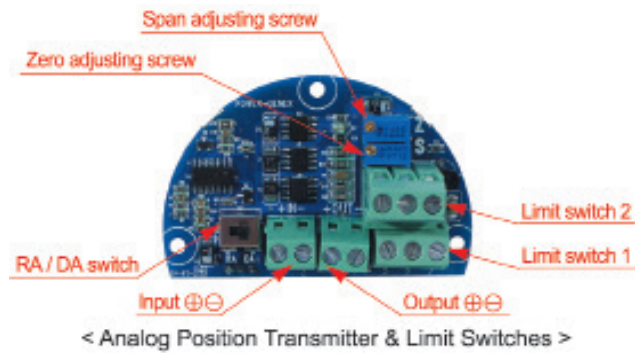

3. Wiring Diagram

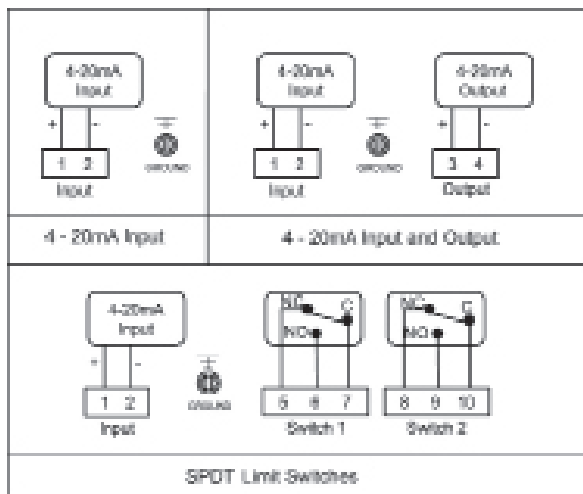

4. SPDT Limit Switches

a. Specifications

Contacts	SPDT Form C
AC Rating	16 A ½ HP 125/250 VAC
DC Rating	0.6 A 125 VDC / 0.3 A 250 VDC
Adjustment	Cams with set screws (L-wrench included for setting)

2. Position Transmitter (4-20mA output signal)

a. Specifications

Power Supply Rating	5.5-30 VDC loop power
Recommended Power Supply	24 VDC
Output Signal	4-20 mA, 2-wire
Operating Temperature	-20°C ~ +85°C
Load Impedance	0 ~ 600 ohms
Max. Output	30 mA DC
Linearity	± 1.0 %
Hysteresis	1.0 % of full scale
Repeatability	±0.5 % of full scale
Adjustment	Zero and Span in terminal box

b. with mA calibrator

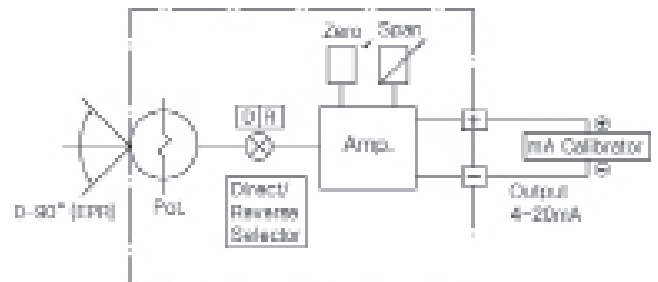

c. with multimeter

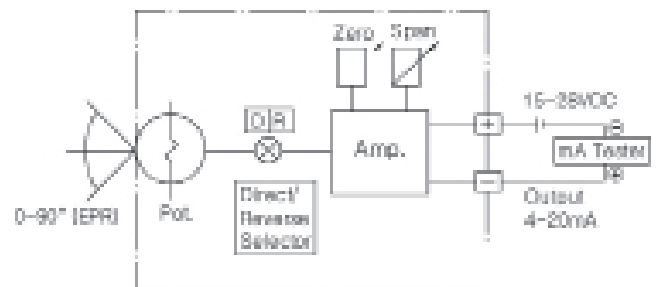

b) Wiring and Application

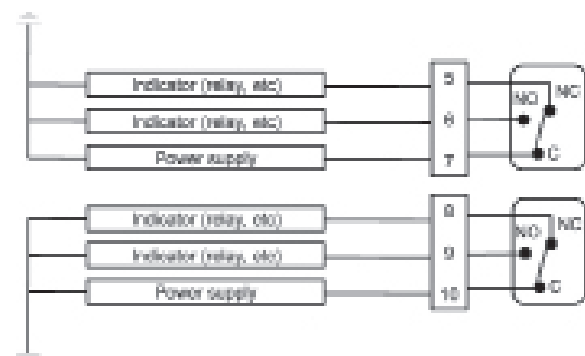

HOW TO ORDER

EPR

Protection Class	Feedback Shaft	Pressure Gauge (SUP, OUT)	Pilot Valve Orifice	Position Feedback	Connection Threads	Dome Indicator	Operating Temp.	Mounting Bracket
------------------	----------------	---------------------------	---------------------	-------------------	--------------------	----------------	-----------------	------------------

Description	Code
Protection Class:	F: KC flameproof Ex dmb IIB+H2 T6 NEPSI flameproof Ex dmb IIB+H2 T6 A: KC flameproof Ex dmb IIC T6/T5 D: IECEx flameproof Ex dmb IIC T6 I: IECEx intrinsically safe Ex ia IIC T6 ATEX intrinsically safe Ex ia IIC T6 KC intrinsically safe Ex ia IIC T6
Feedback Shaft:	N: NAMUR shaft (direct mounting) A: Fork lever M6 x 40L B: Fork lever other size on request
Pressure Gauge	1: 6 bar (90psi)
Pilot Valve Orifice:	S: Standard (Actuator volume over 180 cm ³) M: Small orifice (Ø 1.0 or Ø0.7)
Position Feedback: (only for weather-proof type)	N:None (standard) O: Analog position transmitter (4~20mA output signal) S: Smart position transmitter (4~20mA output signal) L: 2 x SPDT limit switch P: 2 x proximity sensor P&F NJ2-V3-N M: O + L Q: O + P

Description	Code
Connection Threads: (pneumatic)	3: PT(Rc) ¼ 4: NPT ¼ 5: PR(Rc) ¼ - M20 x 1.5
Dome Indicator:	N: Flat indicator (standard) D: Dome indicator
Operating Temperature: (only for weather-proof type)	T: 70°C (standard) H: 120°C (without position feedback option) 85°C (with position feedback option)
Mounting Bracket - NAMUR Shaft Type:	N: None R: Multi-size NAMUR bracket for IEC 60534-6-2/VDI/VDE 3845 (130 x 30 x 50 bracket on request)
- Fork Lever Type:	F: PG bracket 80x30 for fork lever type E: Multi-size NAMUR bracket for Fork lever type (130 x 30 x 50 bracket on request)

DIMENSION SKETCH

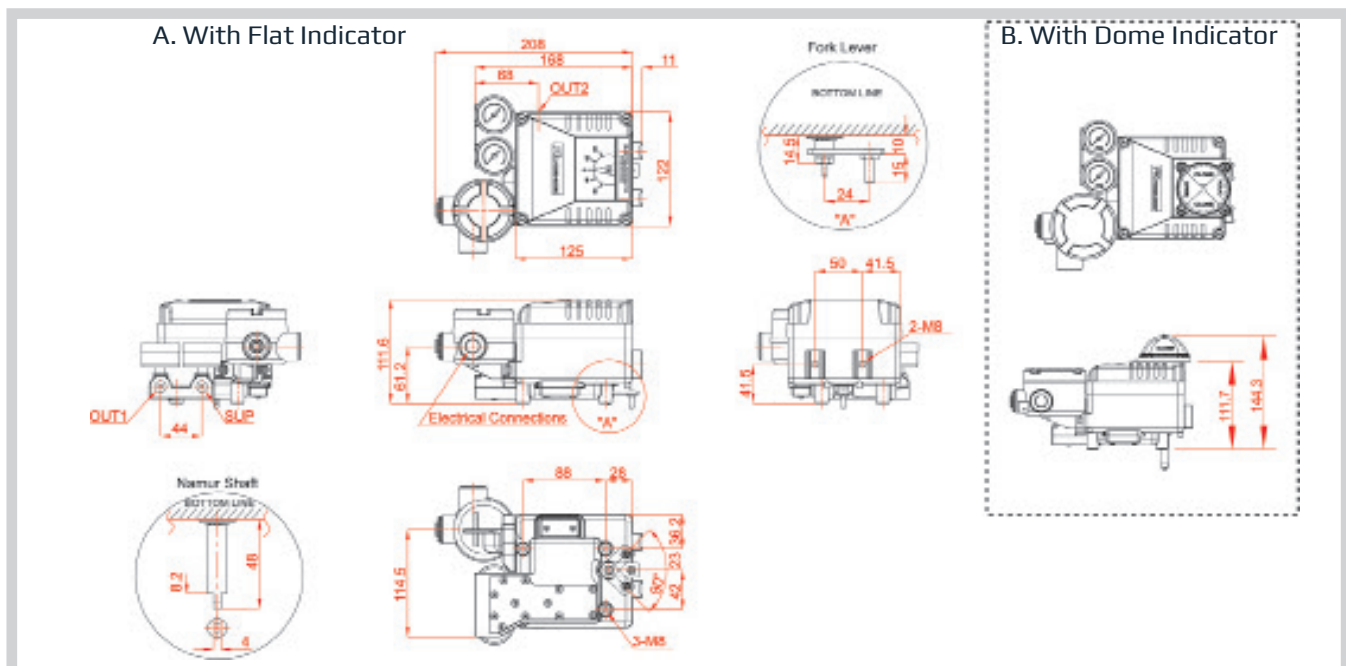

6

Pneumatic indicating controllers and transmitters

Series 80

0-6.7.01-C

Page 1 of 2



APPLICATIONS

For the control of temperature and pressure in industrial or process plants. The indicating controller is used for control of liquid, gaseous or vaporous media. The instrument senses the temperature/pressure of the measured medium directly, displays the operating value, compares the measured variable with the set point and puts out a pneumatic signal in the standard range of 0.2 to 1 bar or 3 to 15 psi. This output pressure actuates the final control element. Four control forms are available: ON-OFF, P, P+I, P+I+D. The units can also be used for remote control of processes operating whether with a pneumatic transmitter (output 0.2-1 bar or 3-15 psi) or as a receiver controller (input 0.2-1 bar, 3-15 psi).

FEATURES

- Robust design
- Maintenance free
- Easy installation
- User friendly
- Can be used for remote control of processes

TECHNICAL DATA

Body	Die cast aluminium with anti corrosive paint
Cover	ABS
Degree of protection	IP55
Mounting	Wall or panel
Pneumatic connections	¼" NPT
Supply air pressure	20±1.5 psi / 1.4 ± 0.1 bar
Output	3-15 psi / 0.2-1 bar
Proportional action	Proportional band ∞...200%
Integral action	>0...>10 rep. /min.
Derivative action	0...>5 min. rep
Steady state air consumption	Air supply 20 psi/1,4 bar 0,13 Nm³/h
Max. air delivery	Air supply 20 psi / 1,4 bar 2,6 Nm³/h
Accuracy	≤ 1% deviation
Hysteresis	≤ 0.5%
Non linearity	≤ 0.5%
Repeatability	≤ 0.5%
Control range	0...150 °C
Permissible ambient temperature	-20...+ 80 °C
Weight	~3 kg

TEMPERATURE ELEMENT

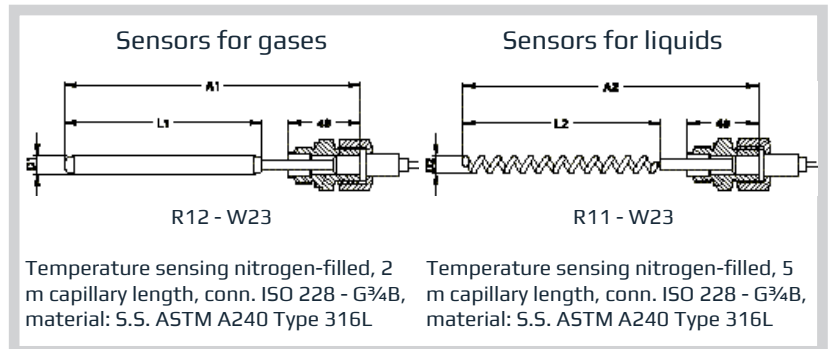

SPAN	25 °C	30 °C	40 °C	50 °C	60 °C	70 °C	80 °C	100 °C	120 °C	130 °C	150 °C	200 °C	250 °C	300 °C	400 °C	500 °C
A1	250	250	250	200	200	200	200	200	200	200	200	200	200	200	200	200
L1	170	170	170	120	120	120	120	120	120	120	120	120	120	120	120	120
D1	13	13	13	13	13	13	13	13	13	13	13	13	13	13	13	13
A2	250	250	250	200	200	200	200	200	200	200	200	200	200	200	200	200
L2	170	170	170	130	130	120	120	120	120	120	120	120	120	120	120	120
D2	16	16	16	16	16	16	14	14	14	14	14	14	14	14	14	14

OPTIONS

- External set point knob
- Box for tropical conditions
- Output signal 6 to 30 psi / 0.4 to 2 bar

Subject to change without notice.

DIMENSIONS

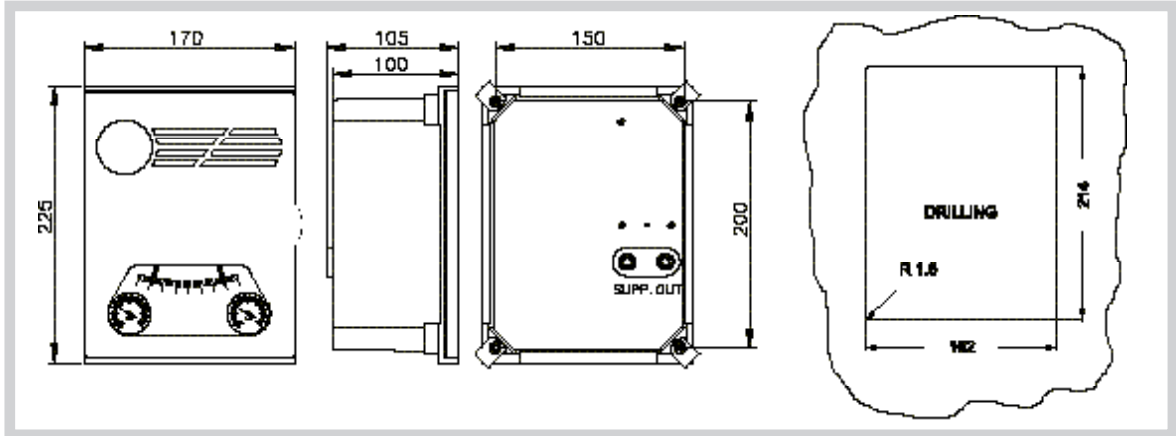

CODIFICATION

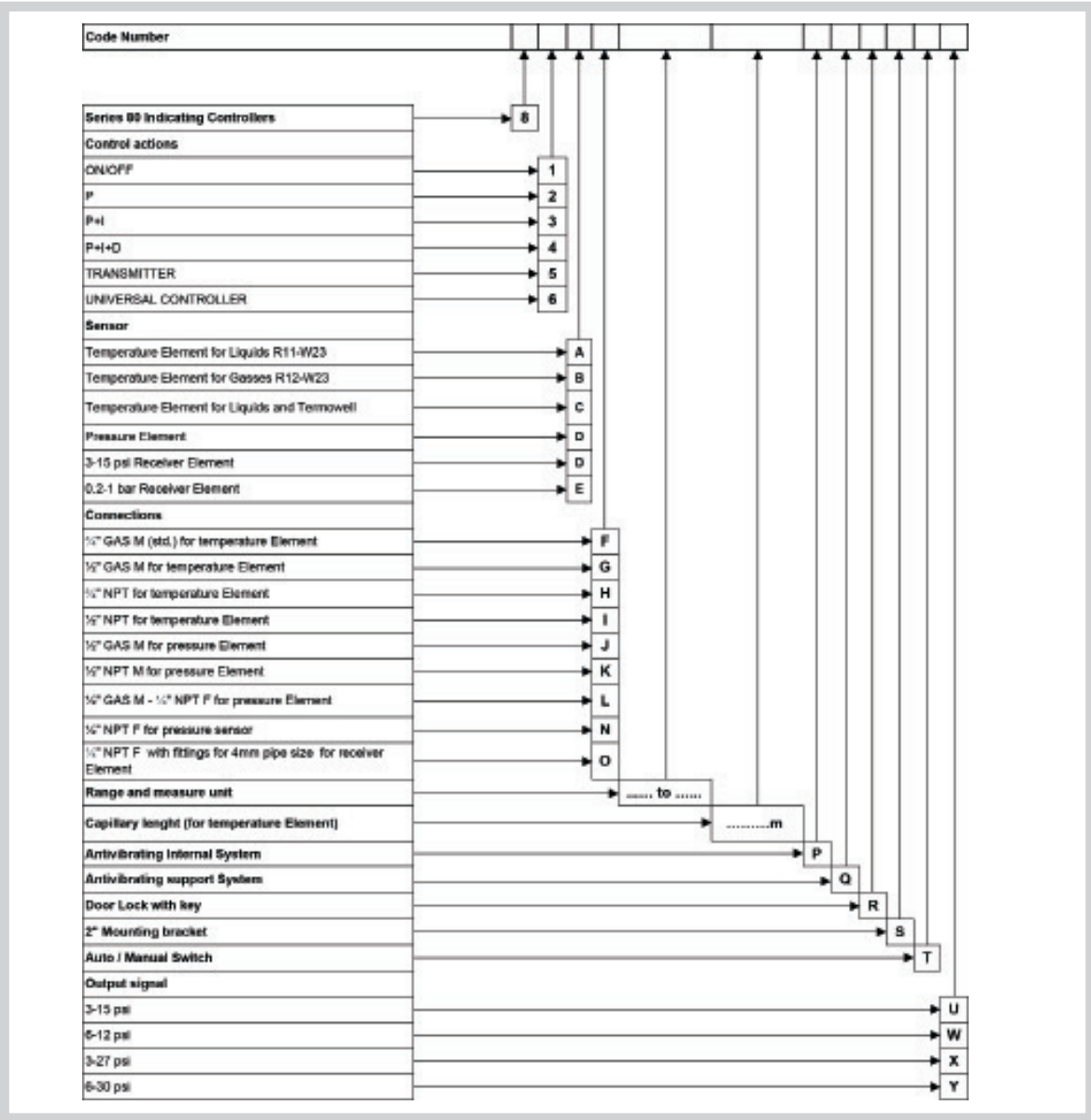

AW 20K-FO2CE-H

Filter Regulator AW20K

0-6.8.01-C



DESIGN

Integrated filter and regulator units save space and require less piping. With the backflow function it incorporates a mechanism to exhaust the air pressure in the outlet side reliably and quickly.

FEATURES

- Space saving and requires less piping
- No manual draining due to auto drain function

TECHNICAL DATA

With backflow function	YES
Thread type	G 1/8
Port Size	1/4
Float type auto drain	Float type auto drain N.C. type-0.1 MPa (AD27)
Pressure gauge	Square embedded type pressure gauge (with limit indicator)
Body	Material Zinc die-cast Color Platinum Silver
Bonnet	Polyacetal Black
Port Size	1/4
Pressure gauge port size	1/8
Fluid	Air
Ambient and fluid temperature	-5 to 60°C
Proof pressure	1.5 MPa
Maximum operating pressure	1.0 MPa
Set pressure range	0.05 to 0.85 MPa
Relief pressure	Set pressure + 0.05 MPa at relief flow rate of 0.1
Nominal filtration rating	
Drain capacity (cm³)	8
Bowl material	Polycarbonate
Optional	Replaceable with Nylon bowl part no. AD27-6
Bowl guard	Semi-standard
Construction	Relieving type
Mass (kg)	0.32
	Resistan to oil mist. (AW20K-FO2CEH-6-B)

Subject to change without notice.

FLOW CHARACTERISTICS

AW20(K)-B

Rc1/4

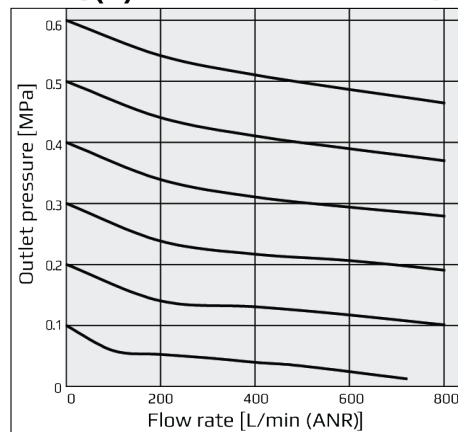

PRESSURE CHARACTERISTICS

AW20(K)-B

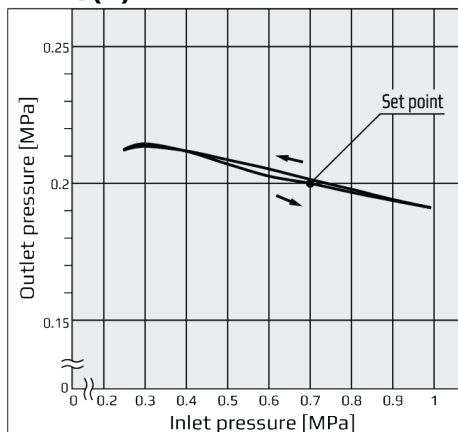

OPTIONS/PART NO.

Float type auto drain ^{1,2}

AD27

¹ Minimum operating pressure: N.O. type-0.1 MPa; (AD27)

² Please consult Clorius Controls for details on drain piping to fit NPT or G port sizes

WORKING PRINCIPLE

When the inlet pressure is higher than the regulating pressure, check valve (2) closes and operates as a normal regulator (**Figure 1**). When the inlet pressure is shut off and released, check valve (2) opens and the pressure in the diaphragm chamber (1) is released in the inlet side.

This lowers the pressure in diaphragm chamber (1) and the force generated by pressure regulator spring (3) lifts the diaphragm. Valve (4) opens through the stem, and the outlet pressure is released to the inlet side.

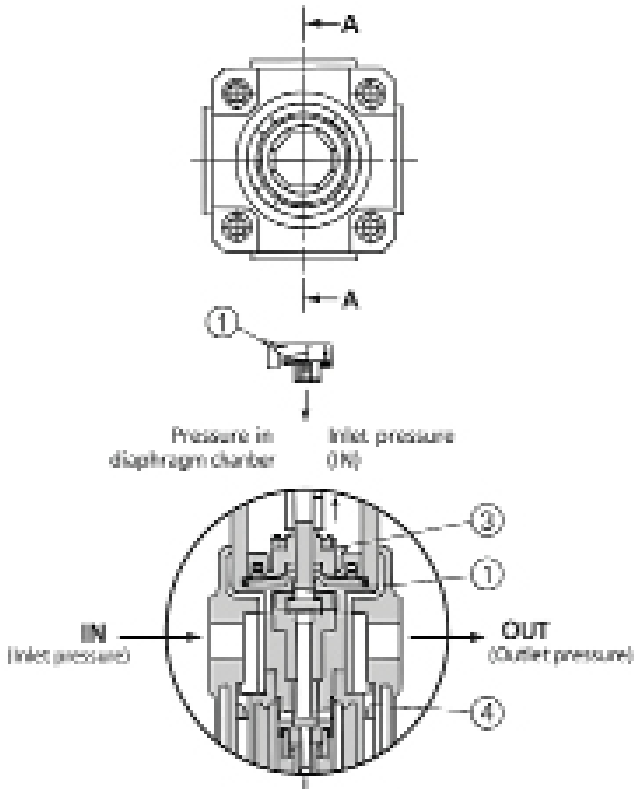

Figure 1 Normal

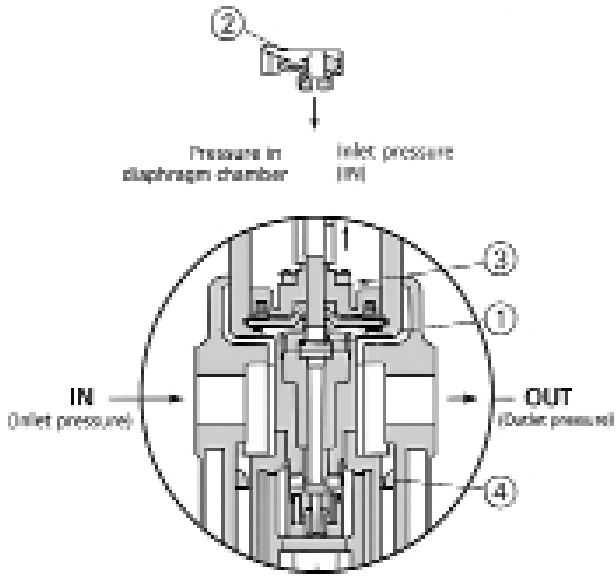

Figure 2 Backflow

AW 20K-FO2CE-H

Filter Regulator AW20K

0-6.8.01-C

DIMENSION SKETCH

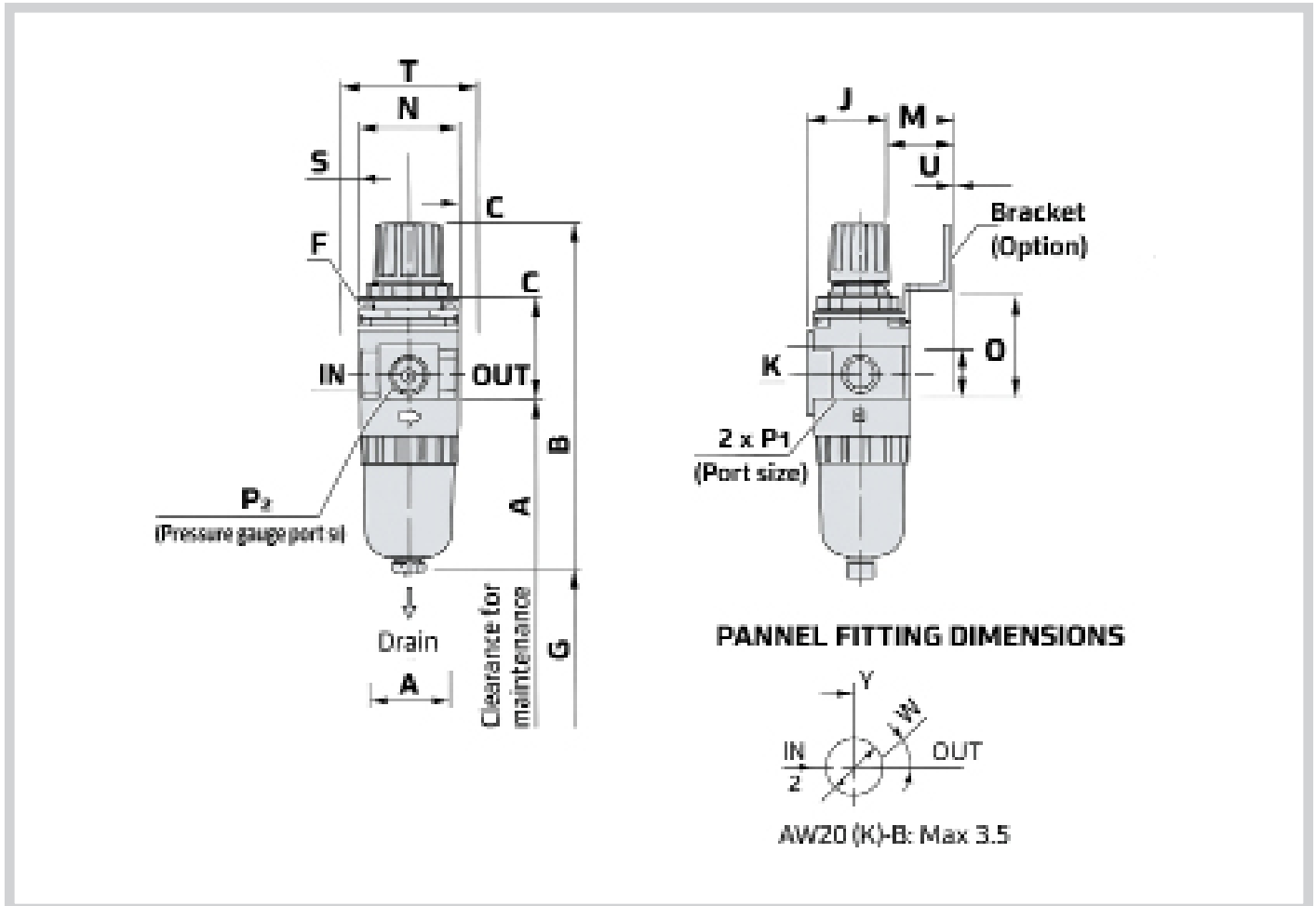

Model	Standard specifications										
	P1	P2	A	B(note)	C	D	E	F	G	J	K
AW20K	1/8	1/8	40	160	73	26	-	M28x1	40	26	S

Model	Standard specifications											
	Bracket mount							Panel Mount				With auto drain
	M	N	Q	R	S	T	U	V	W	Y	Z	B ^(note)
AW20K	30	34	44	5.4	15.-4	55	2.3	30	28.5	14	6	177

Note) The total length of B dimension is the length when the filter regulator knob is unlocked.

SPECIFIC PRODUCT PRECAUTIONS

Maintenance

WARNING

1. Replace the regulator when the pressure drop becomes 0.1 MPa

Mounting and adjusting

WARNING

1. Set the regulator while verifying the displayed values of the inlet and outlet pressure gauges. Turning the regulator knob excessively can cause damage to the internal parts.
2. The pressure gauge included with regulators for 0.02 to 0.2 MPa setting is for up to 0.2 MPa use only. Exceeding 0.2 MPa of pressure can damage the gauge.
3. Do not use tools on the pressure regulator knob as this may cause damage. It must be operated manually.

CAUTION

1. Be sure to unlock the knob before adjusting the pressure and lock it after setting the pressure. Failure to follow this procedure can cause damage to the knob and the outlet pressure may fluctuate.
 - Pull the pressure regulator knob to unlock. (You can visually verify this with the “orange mark” that appears in the gap.)
 - Push the pressure regulator knob to lock. When the knob is not easily locked, turn it left and right a little and then push it (when the knob is locked, the “orange mark”, i.e. the gap will disappear).

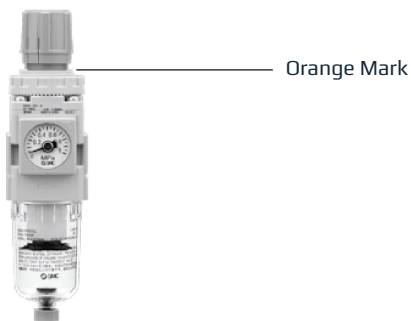

2. A knob cover is available to prevent careless operation of the knob. Refer to page 90 for details.



**UNRIVALED ACCURACY
& STABILITY**

High-performing and self-acting differential pressure controller which allows for fast installation and easy maintenance. Optimized for flow stability.



DIFFERENTIAL PRESSURE CONTROLS

7

OUR DIFFERENTIAL PRESSURE CONTROLS PROGRAM INCLUDES:

TYPE

TDS
TD66
TD56-2
TDL

Pressure Differential Controls

Type TD

0-3.9.01-L

Page 1 of 2



TD66



TD56-2

Pressure differential controls, type TD, comprise a control valve, a diaphragm unit and 2 connecting capillaries.

The large controls type TD56-2, TD66-4 and TD66-8 can be used with our wide range of 2-way control valves, in sizes from 4 mm up to 80 mm (type TD56-2M up to DN 150 mm).

For fast and accurate valve selection and sizing.

Visit <http://www.broenclorius.com> or send your request to mail@cloriuscontrols.com. Our experts are ready to assist you.

TD56-2 is delivered complete with actuator and valve - please see datasheet 0.3.9.06.01.

The diaphragm housings are made of cast iron and the diaphragms of synthetic rubber clamped between 2 steel discs. To prevent the diaphragm from being ruptured, a safety overload spring is fitted between the diaphragm and the valve to prevent damage when subjected to excess pressure, forcing the diaphragm against the housing.

The controls are proportional controls. The proportional band is given as a percentage of set pressure value.

The TD-controls are primarily for use in water systems where they maintain a constant differential pressure across 2 points and ensure stable flow conditions.

With the lower pressure connected to the valve side of the diaphragm and the higher pressure to the other side; the differential pressure across the diaphragm will be balanced by the force exerted by the spring. Any change in the differential pressure will cause the diaphragm and the valve mechanism to move up or down to restore the set condition.

WORKING PRINCIPLE OF THE TD-CONTROLS

Fig. 1. In the control valve the pressure is reduced from P1 to P2, and the control keeps (P2-P3) constant at a set value, although the external pressures "P1" and "P3" or the resistance "R" may be fluctuating. Sizing of the valve is based on the smallest value of (P1-P2) with the maximum flow.

For fast and accurate valve selection and sizing.

Visit <http://www.broenclorius.com> or send your request to mail@cloriuscontrols.com

Similarly, **fig. 2** shows the TD-control installed after the resistance "R" (in the return flow). In this case, (P2-P3) forms the basis for sizing the valve.

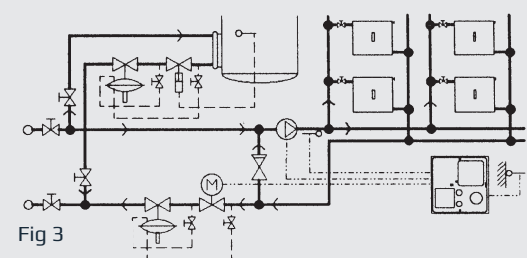
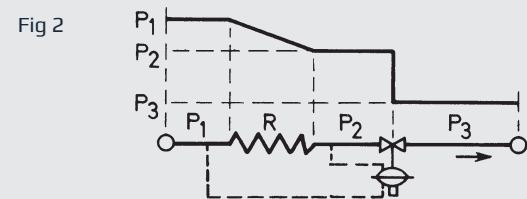
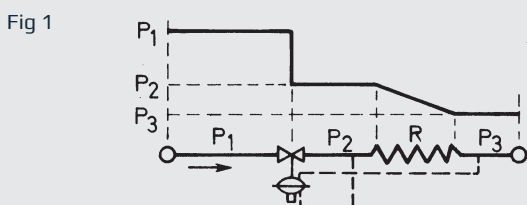

Fig 3

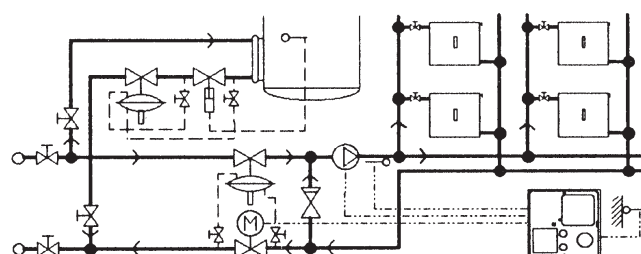

Fig. 4

APPLICATIONS

District Heating - in Housing Circuits without by-passes

The function of the TD-controls is to reduce the high and fluctuating pump head in the district heating system to a suitable and, under all circumstances, a constant differential pressure. It is very important that the TD-controls reduce the water flow as much as possible, to satisfy the design temperature drop across radiators and maintain heat output without excessive water flow.

An inexpensive arrangement for a district heating scheme is to use the TD-control instead of a return by-pass to reduce the flow rate to a minimum. This results in small bore pipework and reduces the need for additional pumps or electrically operated controls.

Depending on the circumstances, the TD-controls may be installed in the return main (fig. 3) or the flow main (fig. 4). Installation in the return main is preferable where there is a risk of air in the system, and in high buildings where the pressure in the return main does not considerably exceed the static head. For low buildings, and high flow pressures, it is normally preferable to install the TD in the flow main to reduce the pressure in the radiators to a level almost equivalent to the static head in the return main. Please also note the TD-control in the district heating circuit of the hot water tank (H.W.T), and that the capillaries are connected across the control valves, maintaining a constant differential pressure across the valves and an optimum control. The H.W.T's control valve should be as small as possible ensuring a slow heating and a good cooling of the district heating water.

Pressure Stabilization for Temperature Control

The TD-controls also apply for heating systems with heat exchangers see fig. 5. When temperatures have to be kept within close limits e.g. in ventilating plants, control may be difficult if the differential pressure in the system is not constant or is very high. This can be overcome by installing a TD-control in front of one or more places to be controlled. Examples are shown in fig. 6, and 7.

Fig. 6 is for district heating, direct supply, whereas fig. 7 is for boiler supply. Note that a by-pass is established by a 3-way valve and a TD control.

The TD-controls can be used with our range of reverse acting valves in by-pass around pumps or across the flow and return pipes of a circuit - see fig. 8 (boiler supply). This avoids the pump working against a dead head when all the sub-circuits are closed down and stops any bypassing on motorised valves or thermostatic radiator valves.

Noise Prevention

Noise from central heating installations can often be overcome by TD-controls. The noise arising from a control valve is normally related to the pressure drop across it. Experts recommend that the pressure drop across radiator valves should not exceed 0,08 bar, especially in the case of living room applications. In blocks of buildings with a common district heating station, there has, in recent years, been a tendency to increase the main pump head and this often results in valve noise.

Fig. 9 shows an example of the circuit to a block of buildings. The TD-control on the take off from the distribution main reduces the high pump head to suit the local pump head. The pressure differential across the TD-controls itself may exceed 2 bar if the distribution pump head is high. In such cases, to avoid noise problems, the TD-controls should be installed well away from living quarters and the immediate pipework should be well muffled.

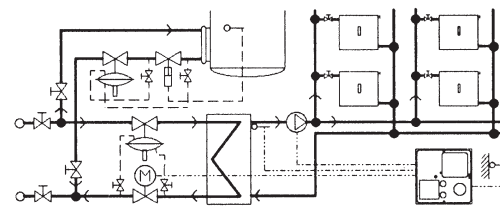

Fig 5

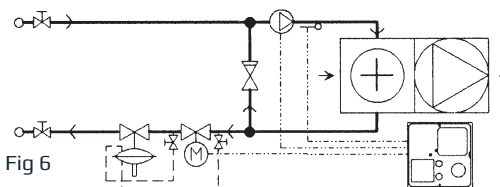

Fig 6

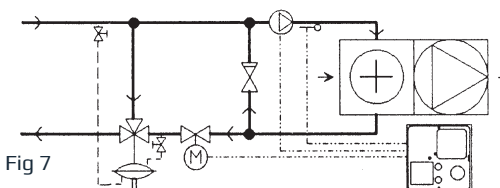

Fig 7

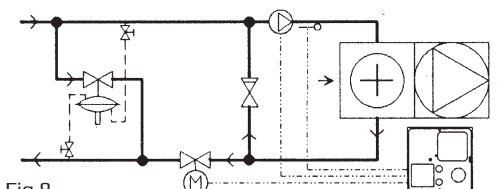

Fig 8

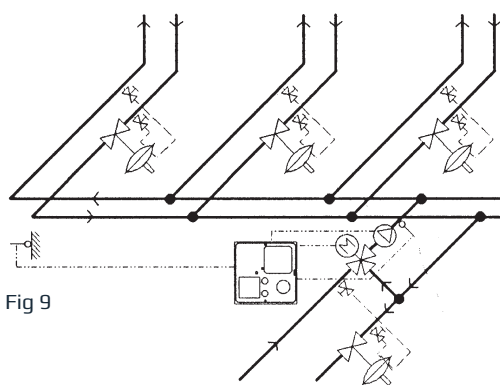

Fig 9

7

Pressure Differential Controller

Type TDL, PN 16, DN 20 – 32 mm

0-3.9.03-E

Page 1 of 2

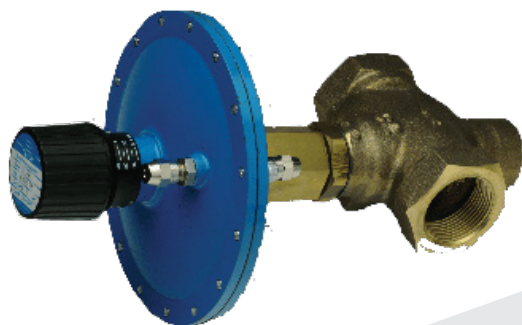

TECHNICAL DATA

Materials:

-Valve body	RG5 CuSn5Zn5Pb5-C
-Cone	Stainless steel (W.no. 1.4305 – AISI 303)
-Diaphragm housing	Nodular cast iron EN-GJS-400-15 (W.no.0.7040 – ASTM A395)
-Diaphragm	EPDM rubber with web reinforcement (ASTM D2000)
-Capillary Pressure stage	2 pieces of 1 m, Cu PN 16

APPLICATIONS

The TDL controllers which are made in 6 variants have the following major applications:

Control of differential pressure, noise and dynamic balance. In individual users circuits and sub-mains within a large distribution network. For example in District Heating or Group Heating networks. Control of by-pass between flow and return where 3 port valves or 2 port zone control valves are installed. To limit volume variations and maximum Δp . Similarly for low water content boilers and devices requiring a minimum circulation irrespective of load conditions. With the addition of a miniature solenoid valve in the impulse connection the valve can also be used to isolate a circuit with respect to time or temperature.

FUNCTION

The TDL controller can be installed in either the flow or return of the sub-circuits.

The high pressure line is connected to the adjustment side of the diaphragm housing and the low pressure line to the valve body side of the diaphragm.

Any change of differential pressure across the diaphragm – which is connected to the valve mechanism – above or below the set point will cause the diaphragm to change its position. If higher than set pressure the valve will move to close, if lower than set pressure the valve will move to open, until the system is once again in balance.

Adjustment of the differential pressure setting is made by rotating the adjusting handle clockwise or anticlockwise until the desired set point is reached (see diagram). The upper edge of the adjustment cap in conjunction with the scale marked on the spring guide tube is an indication of the actual setting. The scale moves into or out of the handle loading the valve and diaphragm. The set pressure is shown on a percentage scale in 10 % increments.

FEATURES

- Good regulating accuracy
- Nominal pressure PN 16
- Max. temperature 150°C

DESIGN

The TDL controller is a self-acting proportional controller consisting of a valve, a diaphragm and housing and two capillary tubes on either side of the diaphragm. The valve body is made of gun metal, and the seat and cone of stainless steel. The diaphragm housing is made of nodular cast iron, and the diaphragm itself is made of EPDM rubber with web reinforcement. If required, the TDL controller adjustment handle can be sealed, preventing unauthorised persons from altering the set point.

Subject to change without notice.

INSTALLATION

According to the conditions, the TDL controller can be built into either the return pipe or the flow pipe in a suitable position. The diaphragm area is large enough to give a sensitive response to small pressure variations; it is designed to be a compact controller without sacrificing performance.

RELATION BETWEEN SCALE SETTING AND DIFFERENTIAL PRESSURE

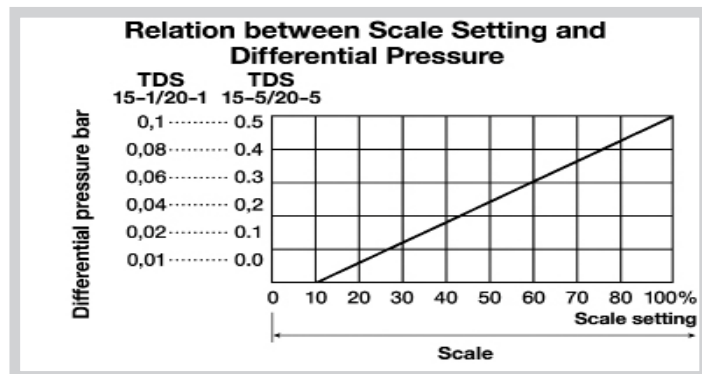

DIMENSION SKETCH

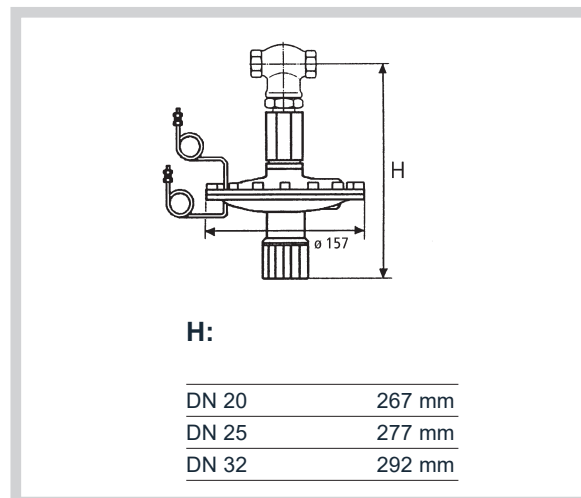

SIZING CHART

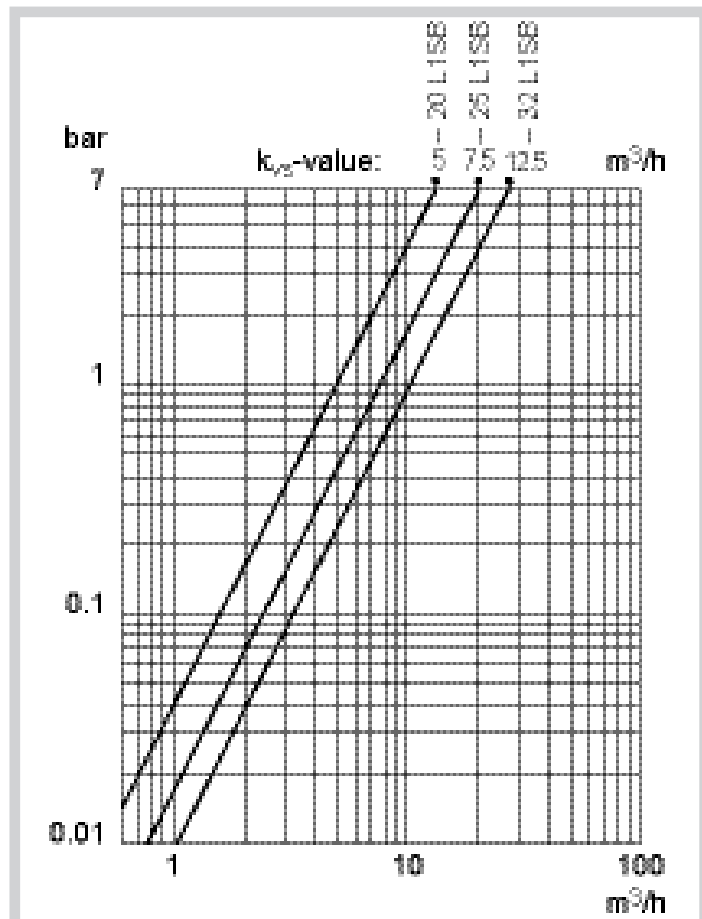

Type designation	TDL 1-20-1	TDL 1-20-5	TDL 1-25-1	TDL 1-25-5	TDL 1-32-1	TDL 1-32-5
Valve type	20 L15B	20 L15B	25 L15B	25 L15B	32 L15B	32 L15B
Pressure stage PN 16	•	•	•	•	•	•
Max. temperature 150°C	•	•	•	•	•	•
Max. diff. pressure, Δp, across the valve in bar	7	7	7	7	7	7
Overall valve length in mm	95	95	105	105	138	138
k _{vs} -value	5	5	7.5	7.5	12.5	12.5
Setting range in bar	0.02-0.1	0.1-0.5	0.02-0.1	0.1-0.5	0.02-0.1	0.1-0.5
Proportional band 10%	•	•	•	•	•	•
Weight in kg, incl. Valve	3.7	3.7	4	4	5.3	5.3
2 pcs capillary each 1 m enclosed, connection ISO 7 - R ¼	•	•	•	•	•	•

Pressure Differential Controls

Type TD66

0-3.9.04-D

Page 1 of 2



TECHNICAL DATA

Materials:

-Diaphragm

EPDM rubber with
web reinforcement
(ASTM D2000)

-Capillary

2 pieces Cu

Pressure stage

PN 16

Pressure differential controls, type TD66, comprise a control valve, a diaphragm unit and 2 connecting capillaries.

The controls type TD66-4 and TD66-8 can be used with our wide range of 2-way control valves, in sizes from 4 mm up to 80 mm. For further information see technical data and data sheets on individual valves. For quick and accurate valve selection and valve sizing, we advise you to visit our website www.broenclorius.com or contact us at mail@cloriuscontrols.com.

Type TD66 (TD66-4 and -8) is spring loaded and is available in several setting ranges. The differential pressure required is set by turning the handle, the upper edge of which acts as a pointer on the scale.

FEATURES

- Good regulating accuracy
- Nominal pressure PN 16
- Max. temperature 120°C (150° C dependant on the installation)
- Self-acting

DIMENSION SKETCH

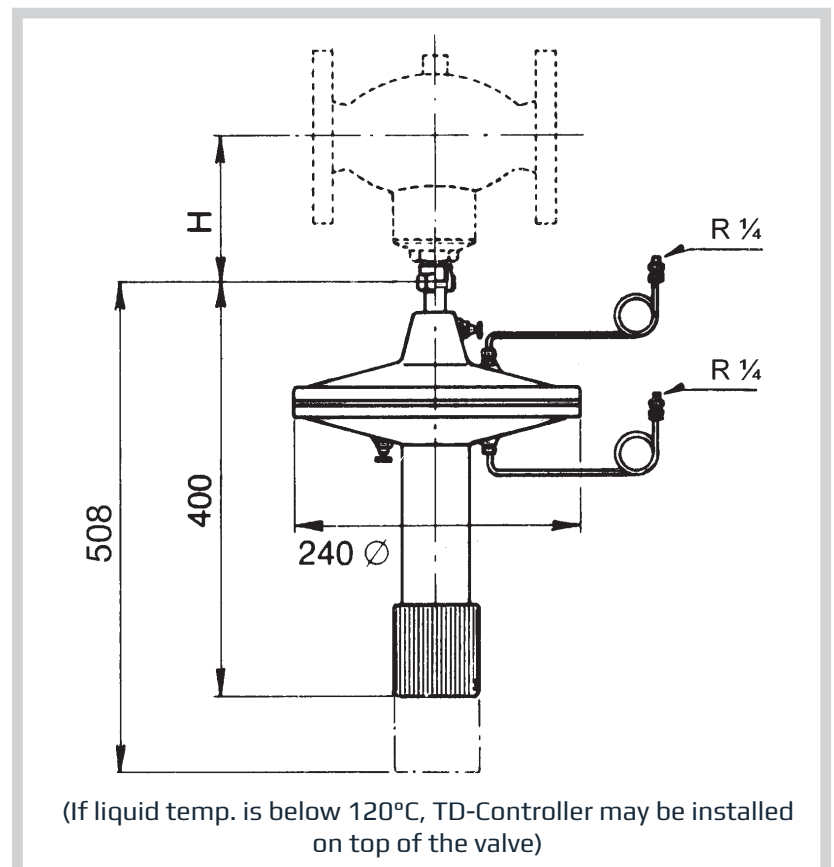

TECHNICAL DATA

Type		TD66-4	TD66-8			
Setting range	bar	0.15-0.3	0.15-0.3	0.2-0.8	0.7-1.3	1.35-1.5
Proportional band		10%	10%	30%	30%	20%
Max. thrust on stem	N	400	800			
Nom. pressure PN	bar	16 ¹⁾	161)			
Max. rated travel	mm	14	14			
Max. temp. of liquid	°C	120 (150) ²⁾	120 (150) ²⁾			
Weight	kg	13				
Note	Primarily in connection with double seated valves up to DN 80 mm (Single seated valves only up to DN 25 mm, and not balanced valves - type M1FB, G1FB, H1FB) ³⁾					

1) PN is only valid for the diaphragm housing. See also data sheets for the valves.

2) 150°C - Only if TD controller is installed below the valve.

3) Balanced and larger single seated valves only to be selected if an increased variation of the desired diff. pressure Δp is allowable.
(An increase of the inlet pressure may result in a substantial increase of Δp).

Self-acting Differential Pressure Controls

Type TD56-2G (PN 25) and TD56-2M (PN 16), DN 15 – 80 mm

0-3.9.06.01-H

Page 1 of 2



TECHNICAL DATA

Materials:

- TD56-2M valve body	Nodular cast iron EN-GJS-400-15
- TD56-2G valve body	Nodular cast iron EN-GJS-400-15
- Cone, Seat	Stainless steel
- O-ring	A70H FEPM
- Bolts, nuts	24 CrMo 4/A4
- Stag bolt, Set point adjuster	St. 42, 1.0503 Electroplated
- Spindle housing	St. 42, 1.0503 Electroplated
- Spring	W. Nr. 1.4568 powder coated
- Diaphragm housing	Steel 1.0122
- Diaphragm	NBR / EPDM
Nominal pressure	TD56-2G - 25 bar TD56-2M - 16 bar
Seating	Single-seated
Flow characteristic	Quadratic
Leakage rate	≤ 0.05% of Kvs
Flanges drilled according to:	
- TD56-2G	EN 1092-2 PN 25
- TD56-2M	EN 1092-2 PN 16
Counter flanges	DIN 2634
Colour (valve body, cover):	
- TD56-2G	Gray
- TD56-2M	Grey

Subject to change without notice.

APPLICATIONS

This unit is designed for controlling of differential pressure in individual users circuits and sub-mains within a large distribution network. For instance in district heating or group heating networks. Control of by-pass between flow and return where 3 way valves or 2 way zone control valves are installed to limit volume variations and maximum Δp . Similarly for low water content boilers and devices requiring a minimum circulation irrespective of load conditions.

FUNCTION

The medium flows through the free area between the seat and cone in the direction indicated by the arrow on the body.

The high pressure line is connected to the diaphragm housing via **C1** and the low pressure line to the diaphragm housing via **C2**. Any change of differential pressure across the diaphragm which is connected to the valve mechanism – above or below the set point will cause the diaphragm to change its position.

If higher than set pressure the valve will move to close, if lower than set pressure the valve will move to open, until the system is once again in balance. Adjustment of the differential pressure setting is made by rotating the setpoint adjuster clockwise or anticlockwise until the desired set point is reached. The valve cone is pressure balanced. The pressure acts onto the bottom and top surface of the cone at the same time. In this way, the forces produced by the media are compensated.

DESIGN

The differential pressure control valve is a self-acting unit consisting of a valve, springs, an actuator and two capillary tube connected on the upper and lower side of the actuator. The valve body is made of nodular cast iron. The seat and cone are made of stainless steel. The diaphragm is made of EPDM or NBR rubber, depending on the medium to be controlled.

FEATURES

- Exact regulating
- Nominal pressure PN 25 / PN 16
- Self-acting

INSTALLATION

According to the conditions, the TD56-2 can be built into either the return pipe or the flow pipe in a suitable positions. The diaphragm area is large enough to give a sensitive response to small pressure variations.

PRESSURE/TEMPERATURE DIAGRAM

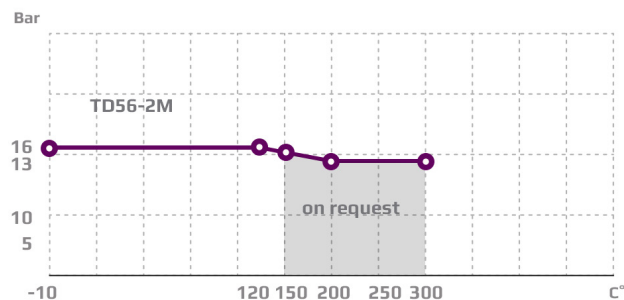
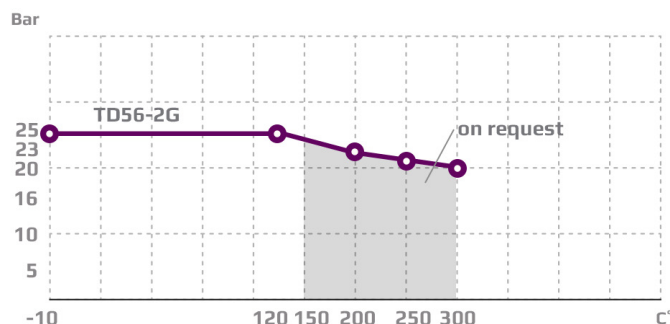

DIMENSION SKETCH

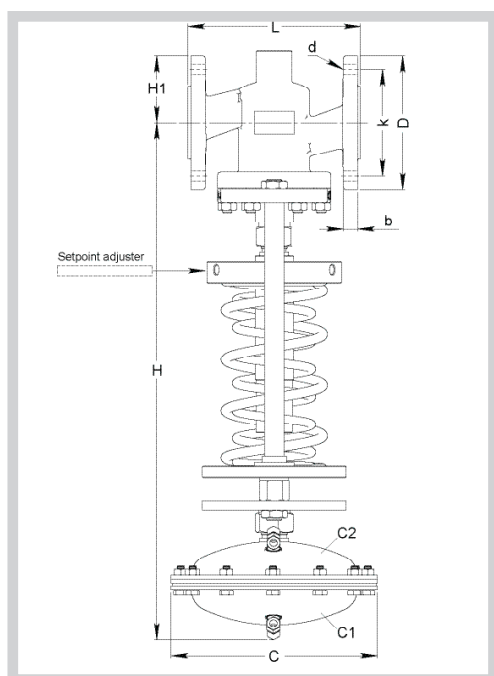

Type	L mm	H mm	H1 mm	C mm	b mm	D (dia.) mm	k (dia.) mm	d mm dia. (number)
15 TD56-2G/M	130	582	60	220	14	95	65	14x(4)
20 TD56-2G/M	150	595	65	220	16	105	75	14x(4)
25 TD56-2G/M	160	601	70	220	16	115	85	14x(4)
32 TD56-2G/M	180	618	75	220	18	140	100	19x(4)
40 TD56-2G/M	200	630	85	220	19	150	110	19x(4)
50 TD56-2G/M	230	660	95	220	19	165	125	19x(4)
65 TD56-2G/M	290	685	110	220	20	185	145	19x(8)
80 TD56-2G/M	310	708	155	220	20	200	160	19x(8)

SPECIFICATIONS

Type	Flange connection	k_{vs} -value m^3/h	Lifting height mm	Weight kg
15 TD56-2G/M	15	4	7.5	21
20 TD56-2G/M	20	6,3	7.5	23
25 TD56-2G/M	25	10	9	24
32 TD56-2G/M	32	16	10	27
40 TD56-2G/M	40	25	11	29
50 TD56-2G/M	50	35	11.5	33
65 TD56-2G/M	65	58	14.5	38
80 TD56-2G/M	80	80	16	55
Set point bar	0.4-0.8	0.6-1.5	1-2.5	2-5



**RUGGET DEPENDABILITY
& SUPERIOR PERFORMANCE**

Premium and self-acting pressure reducing valve, ideal for maintaining accurate downstream pressure while responding quickly and effectively.

PRESSURE REDUCING VALVES

OUR PRESSURE REDUCING VALVE PROGRAM INCLUDES:

TYPE

G1PR
H1PR

Pressure Reducing Valves

Type G1PR (PN 25) and H1PR (PN 40), DN 15 – 80 mm

0-3.9.08-K

Page 1 of 2



TECHNICAL DATA

Materials:

- H1PR valve body	Cast steel GP240GH (GS-C25)
- G1PR valve body	Nodular cast iron EN-GJS-400-15
- Cone, Seat	Stainless steel
- O-ring	A70H FEPM
- Bolts, nuts	24 CrMo 4/A4
- Stag bolt, Set point adjuster	St. 42, 1.0503 Electroplated
- Spindle housing	St. 42, 1.0503 Electroplated
- Spring	W. Nr. 1.4568 powder coated
- Diaphragm housing	Steel 1.0122
- Diaphragm	NBR / EPDM
Nominal pressure	PN 25 - G1PR PN 40 - H1PR
Seating	Single-seated
Flow characteristic	Quadratic
Leakage rate	$\leq 0.05\%$ of Kvs
Flanges drilled according to:	
- H1PR	EN 1092-1 PN 40
- G1PR	EN 1092-2 PN 25
Counter flanges	"G" DIN 2634 "H" DIN 2635
Colour (valve body, cover):	
- H1PR	Gray
- G1PR	Gray

APPLICATIONS

This unit is designed for maintaining the pressure downstream of the valve to an adjusted set point value.

FUNCTION

The medium flows through the free area between the seat and cone in the direction indicated by the arrow on the body.

The position of the valve cone determines the flow rate and consequently the pressure ratio across the valve. The downstream pressure is transmitted through the compensation chamber and the capillary to the diaphragm, where it is converted into a positioning force. This positioning force is adjusting the cone with dependence on the force of the operating springs. The spring force can be adjusted by using the setpoint adjuster. The valve cone is pressure balanced. The pressure acts onto the bottom and top surface of the cone at the same time. In this way, the forces produced by the media are compensated.

DESIGN

The pressure reducing valve is a self-acting unit consisting of a valve, springs, an actuator and one capillary tube connected on the upper side of the actuator. The valve body is made of nodular cast iron or cast steel. The seat and cone are made of stainless steel. The diaphragm is made of EPDM or NBR rubber, depending on the medium to be controlled.

FEATURES

- Exact regulating
- Nominal pressure PN 25 / PN 40
- Self-acting
- Easy to install and use

INSTALLATION

The pressure reducing valve must be installed in a horizontal pipe with the actuator directed downwards. The flow through the valve must coincide with the arrow on the valve body.

Subject to change without notice.

PRESSURE/TEMPERATURE DIAGRAM

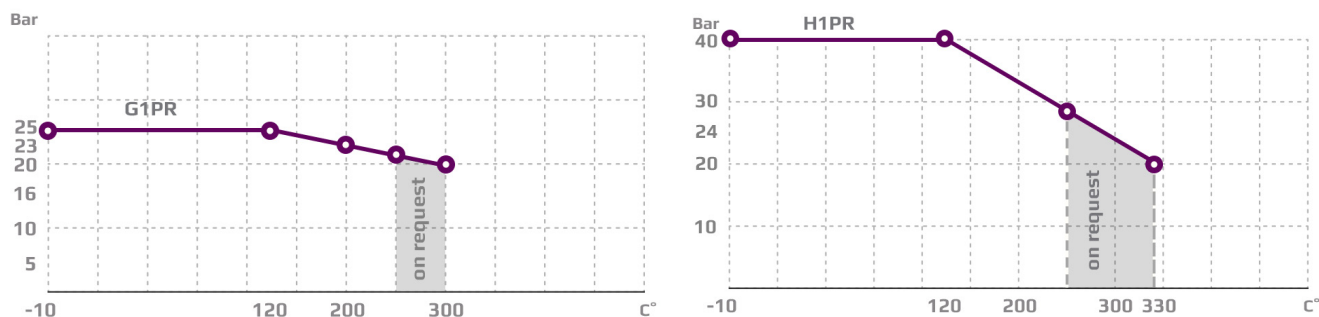

*For temperature above 100°C a compensation chamber is needed.

DIMENSION SKETCH

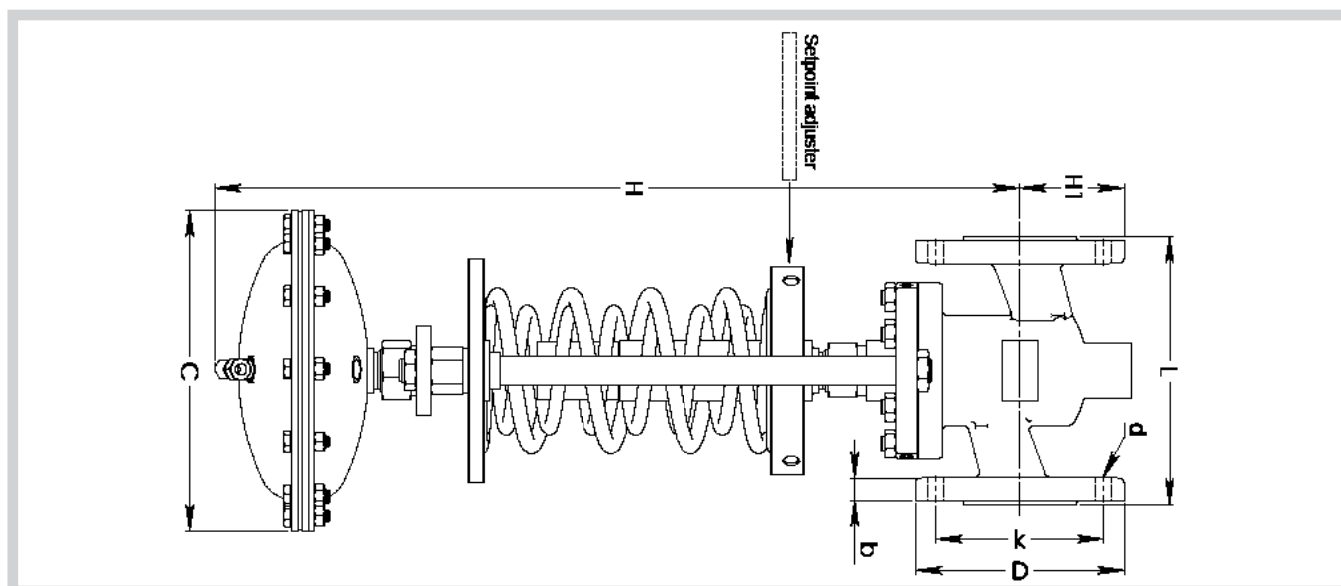

SPECIFICATIONS

Type	L mm	H1 mm	H mm	C mm	b mm	D (dia.) mm	k (dia.) mm	d mm dia. (number)	Flange connection DN in mm	k _{vs} -value m ³ /h	Lifting height mm	Weight kg
15 G/H1PR	130	60	582	220	14	95	65	14x(4)	15	4	7,5	21
20 G/H1PR	150	65	595	220	16	105	75	14x(4)	20	6,3	7,5	23
25 G/H1PR	160	70	601	220	16	115	85	14x(4)	25	10	9	24
32 G/H1PR	180	75	618	220	18	140	100	19x(4)	32	16	10	27
40 G/H1PR	200	85	630	220	19	150	110	19x(4)	40	25	11	29
50 G/H1PR	230	95	660	220	19	165	125	19x(4)	50	35	11,5	33
65 G/H1PR	290	110	685	220	20	185	145	19x(8)	65	58	14,5	38
80 G/H1PR	310	155	708	220	20	200	160	19x(8)	80	80	16	55

SET POINT	bar	0.4-1.2	1-2.5	2,5	4-10
-----------	-----	---------	-------	-----	------

Maximum allowable differential pressure is 25 bar.

VALVE ACCESSORIES
FOR A WIDE VARIETY OF REQUIREMENTS

High quality accessories for a variety of
BROEN - Clorius products

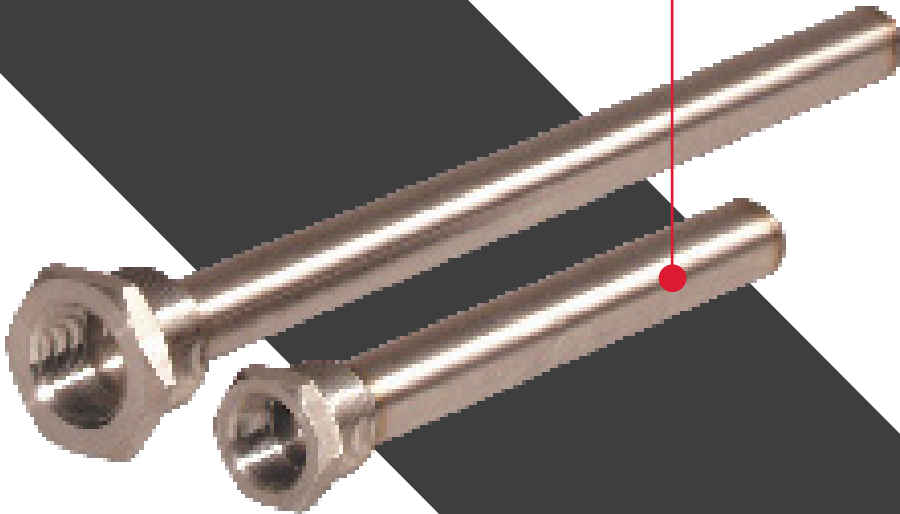

ACCESSORIES

OUR ACCESSORIES PROGRAM INCLUDES:

MODEL

TEMPERATURE SENSORS
TYPE M-F821A, G-F821C, H-F821F
SENSOR POCKETS
SAFETY SETS
COOLING UNITS
MANUAL ADJUSTING DEVICE
SPACER CONCEPT

TYPE

1XPT100, 2XPT100
EPL, EPR
FOR CLORIUS V-THERMOSTATS
SM6
KS-4, KS-5
FOR CLORIUS V-THERMOSTATS
FOR CLORIUS CONTROL VALVES

Temperature sensors

Type FF12-2, FF12 - 4 -20mA and FF15-2, FF15-2 -4-20mA for electronic temperature regulation

0-4.25.01-D

Page 1 of 3

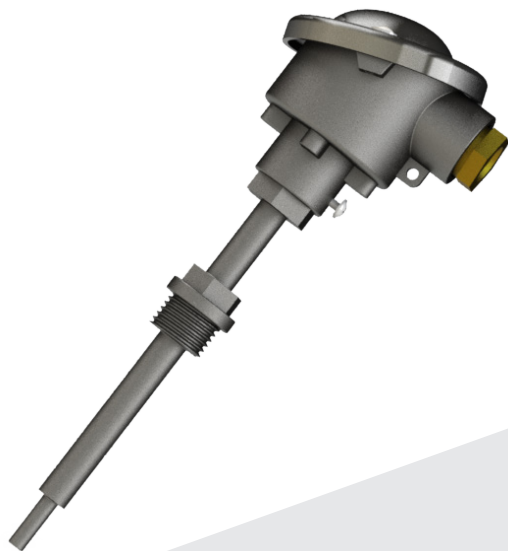

TECHNICAL DATA

DATA FOR POCKETS

According to PN-EN 60751

Material: 1.4404-316L

Connection thread G:	½" BSP, ½" NPT
Permissible torque moment:	50 Nm
Permissible flow velocities:	
-Air:	25 m/s
-Hot steam:	25 m/s
-Water:	3 m/s
Reaction times at liquid velocity:	
-0.4 m/sec:	t 1/2: 7,5s
	t 9/10: 21s
	t = total temperature step

Max. pressure:	50 bar
Max. temperature:	260°C

Weight incl. insert:	1 kg
----------------------	------

DATA FOR MEASURING INSERT

According to PN-EN 60751

Measuring range:	-50°C to + 260°C
Measuring resistance:	1 x Pt 100 Ω or 2 x Pt 100 Ω
Max. temperature:	260°C

Insulation resistance between measuring resistance and insert tube is over 1000 MΩ at room temperature. The insert is made of stainless steel.

Spring travel:	8 mm
----------------	------

Two-core coupling Resistance of inner cables for supply and return line of the measuring insert:	< 0.07 Ω/m
-----------------------------------------------------------------------------------------------------	------------

Weight of loose insert:	0.06 kg
-------------------------	---------

DATA FOR CONNECTION HEAD

According to PN-EN 60751, form B	
Material:	Light-alloy metal
Seal:	IP 65
Ambient temperature:	max. 100°C
Cable Gland:	M20x1,5

APPLICATIONS

The temperature sensors are used for registration of temperatures in tubes, tanks and piping. The output signal of the sensor is used as reference for our ER2022 regulators.

The FF12-2 and FF15-2 with 4-20mA is equipped with a built-in 2-wire transmitter with 4-20 mA output signals.

Due to small installation dimensions and internationally widespread measuring element the sensor is especially fitted for marine purposes, just as the applications on land are innumerable.

DESIGN

The sensor consists of a pocket, a connection head and a measuring insert. The pocket is constructed of acid proof steel and can stand temperature/pressure as stated in the diagram. The connection head is made of light-alloy metal and complies with IP 65. The measuring insert contains one or two measuring windings and are exchangeable. The supply lines of the measuring insert are insulated from each other and from the insert tube with a ceramic insulator. Exchangeable measuring insert is mounted in the connection head by means of two spring loaded screws. This means that the measuring insert is always pressed towards the bottom of the pocket, and vibrations from the surroundings will not be transferred to the measuring insert, just like different heat evolutions of pocket and measuring insert are adjusted. Our standard types are shown in the below diagram.

FEATURES

- Resistance sensor Pt 100 Ω/0°C
- Standardized design according to PN-EN 60751
- Robust and reliable sensor for use in gaseous and liquid media
- For medium temperature up to 260°C
- For pressures up to 50 bar
- Internationally recognized for marine purposes
- To be used together with ER regulators type ER2022

See www.broenclorius.com for further information

STANDARD TYPES

Type	Measuring	Comments
FF12-2	1 x Pt100	With exchangeable measuring insert
FF12-R		Measuring insert for FF 12-2
FF15-2	2 x Pt100	With exchangeable measuring insert
FF15-R		Measuring insert for FF 12-2
FF 12-2, 4-20mA	4-20mA	With exchangeable measuring insert

DIMENSION SKETCH

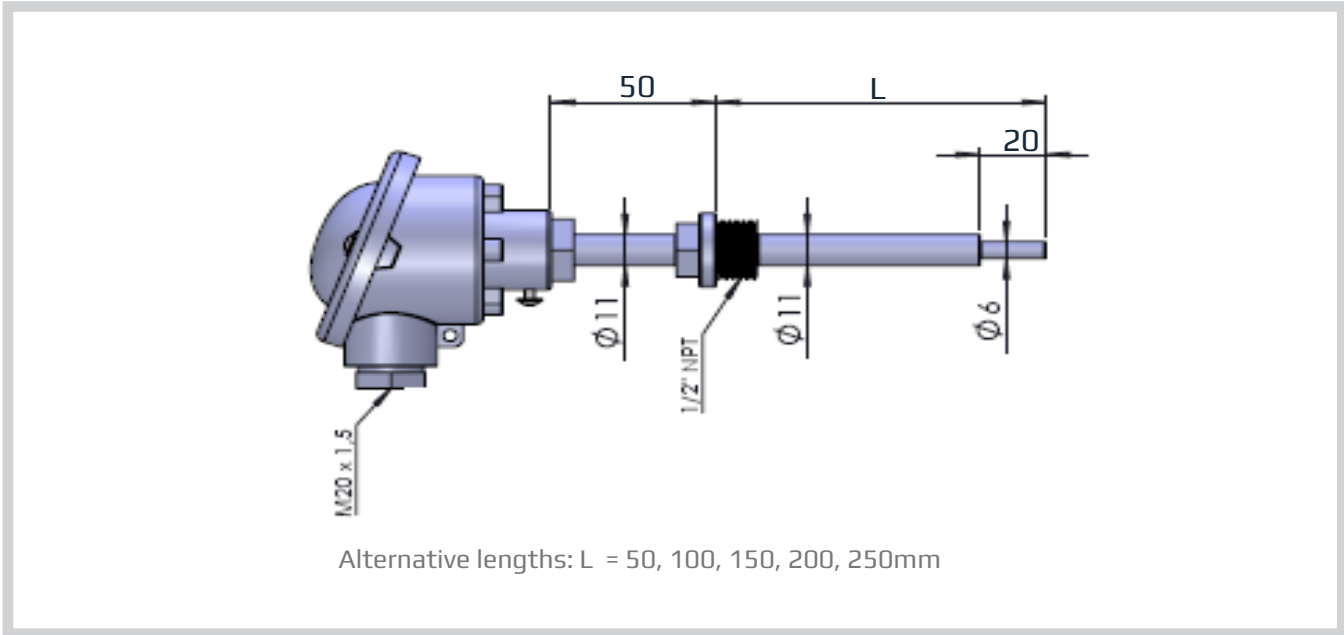

RECOMMENDATIONS REGARDING INSTALLATION OF TEMPERATURE SENSORS IN WATER SYSTEMS

We recommend that the temperature sensors should be installed after a straight pipe. Pipe length should be 3 to 5 times the pipe diameter, especially after pump installation.

When installing the Temperatures sensors please always follow the instruction given in the Clorius installation instruction no. 99.209.01.

EXAMPLES OF MOUNTING POSITIONS

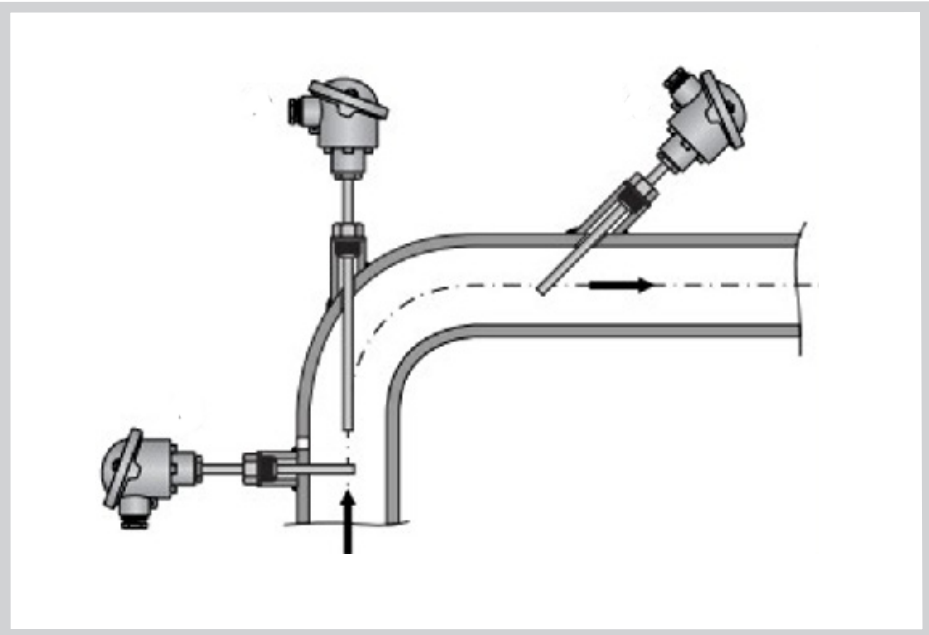

Temperature sensors

Type FF12-2, FF12 - 4 -20mA and FF15-2, FF15-2 -4-20mA for electronic temperature regulation

0-4.25.01-D

Page 3 of 3

PT100 - WIRING DIAGRAM

1 x PT100

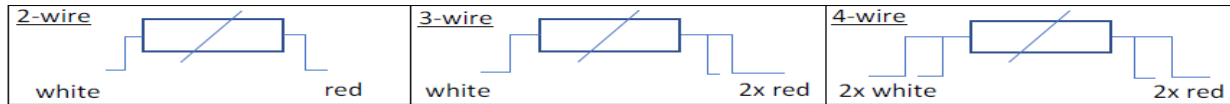

2 x PT100

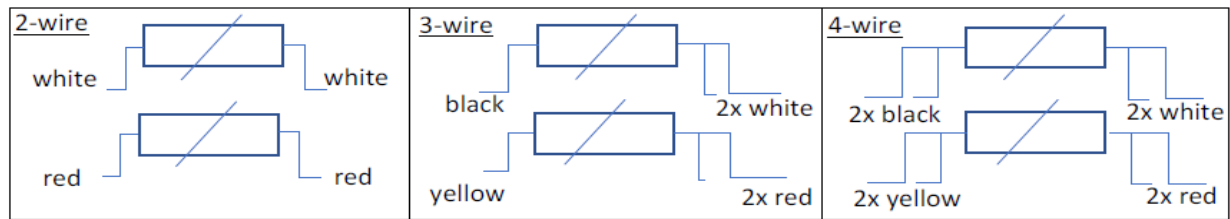

PT100 with transmitter 4-20mA - wiring diagram

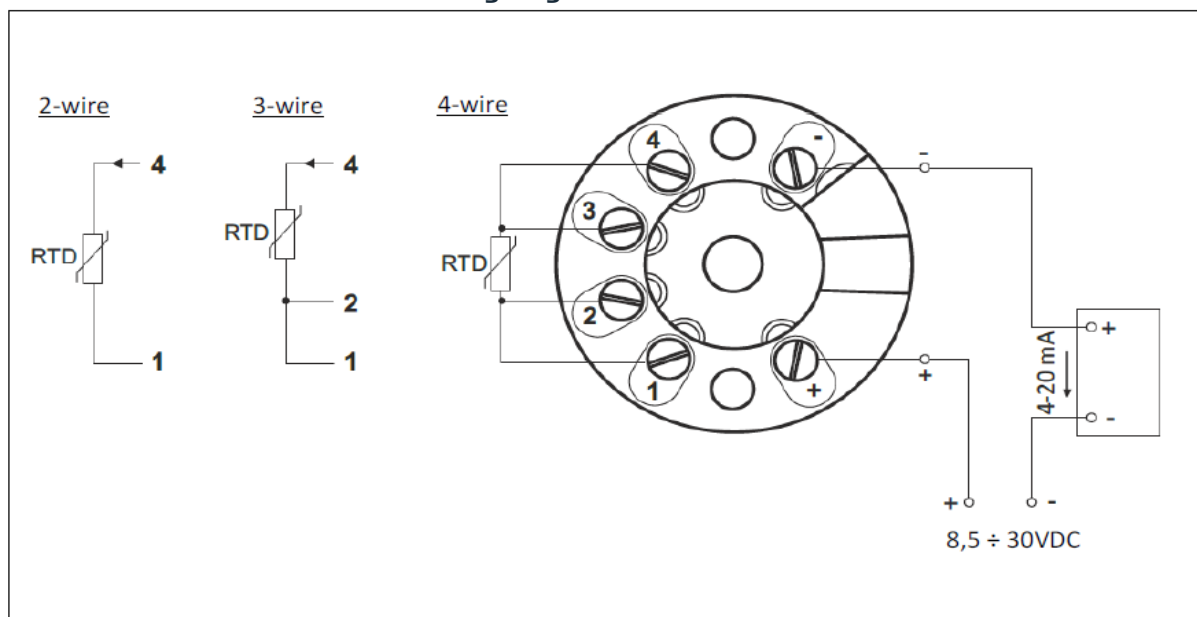

Subject to change without notice.

Y strainers

Type M-F821A, G-F821C and H-F821F

0-8.1.11-E

Page 1 of 2



TECHNICAL DATA

Face-to-face dimension according to EN 558-1 series 1
Flanges drilled according to EN 1092-1 for body material F (H-F821F)
Flanges drilled according to EN 1092-2 for body material A (M-F821A), C (G-F821C)
Closing tightness acc. EN 12266-1

APPLICATIONS

Saturated steam, water, oil, air and other compatible fluids.

DESCRIPTION

The Y strainers are applicable to all types of steam, water, oil and air systems. Their purpose is to protect traps, regulating valves, piping, etc. from dirt which often cause damage and consequently energy loss in fluid systems. Connections are flanged.

INSTALLATION

Horizontal or vertical downstream installation.

FEATURES

- Screen made of stainless steel
- Compact settlement
- Environment-friendly
- Cleaning of screen without disassembling

SPECIFICATIONS

Type	Body material	Nominal pressure PN in bar	Nominal diameter DN in mm	Max temperature °C
G-F821C	A: Grey cast iron	16	15-200	300
	C: Nodular cast iron	25		350
	H-F821F F: Cast steel	40		400

SCREENS

Type	Mesh (mm)	
M-F821A	DN 15-50	1
	DN 65-150	1.25
	DN 200	1.6
G-F821C H-F821F	DN 15-50	1
	DN 65-80	1.25
	DN 100-200	1.6

Mesher in 0.6, 0.5, 0.4, 0.32 and 0.2 mm are available on request.

Subject to change without notice.

DIMENSION SKETCH

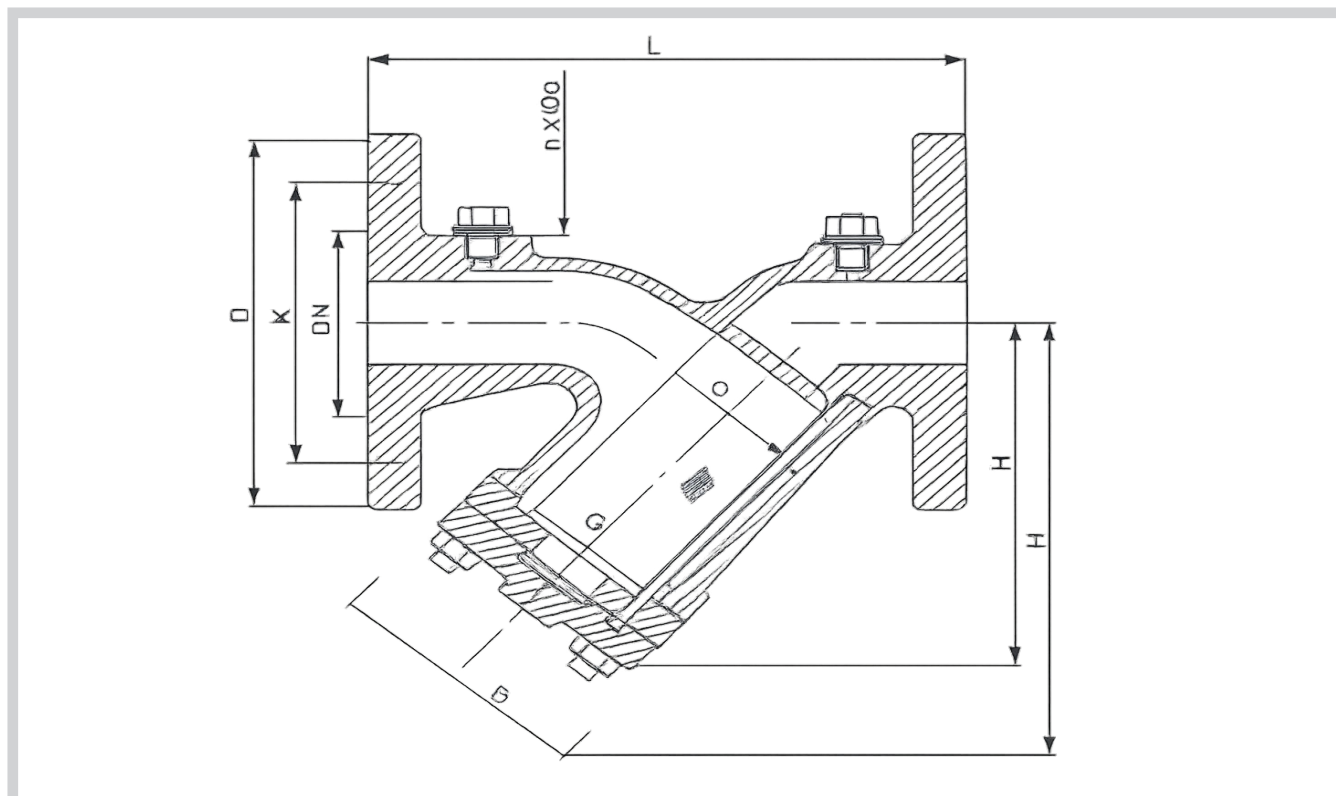

								Type M-F821A, PN 16					Type G-F821C, PN 25					Type H-F821F, PN 40				
DN	L	H	H1	G	C	B	K _v	D	d	K	n x do	Weight	D	d	K	n x do	Weight	D	d	K	n x do	Weight
mm	mm	mm	mm	mm	mm	mm	m ³ /h	mm	mm	mm	mm	kg	mm	mm	mm	mm	kg	mm	mm	mm	mm	kg
15	130	90	135	3/8	23	56	5,7	95	46	65	4x14	2,6	95	46	65	4x14	2,6	95	45	65	4x14	2,7
20	150	100	150	3/8	28	68	10,4	105	56	75	4x14	3	105	56	75	4x14	3	105	58	75	4x14	3,6
25	160	115	180	3/4	36	82	16,4	115	65	85	4x14	4,3	115	65	85	4x14	4,3	115	68	85	4x14	4,5
32	180	135	215	3/4	42	98	27,3	140	76	100	4x19	6,8	140	76	100	4x19	6,8	140	78	100	4x18	6,3
40	200	150	240	1	50	114	42	150	84	110	4x19	8,8	150	84	110	4x19	8,8	150	88	110	4x18	8,7
50	230	160	250	1	61.5	119	64,7	165	99	125	4x19	11	165	99	125	4x19	11	165	102	125	4x18	11
65	290	180	285	1	78.5	134	98	185	118	145	4x19	14,6	185	118	145	8x19	14,6	185	122	145	8x18	18,5
80	310	215	330	1	89.5	149	149	200	132	160	8x19	18,6	200	200	160	8x19	18,6	200	138	160	8x18	23,5
100	350	235	365	1 1/2	109.5	169	234	220	156	180	8x19	27	235	235	190	8x23	27	235	162	190	8x22	33
125	400	280	425	1 1/2	137.5	199	376	250	184	210	8x19	38,5	270	270	220	8x28	38,5	270	188	220	8x26	54
150	480	320	480	1 1/2	160	224	454	285	211	240	8x23	54,5	300	300	250	8x28	54,5	300	218	250	8x26	75
200	600	405	610	1 1/2	210	284	853	340	266	295	12x23	110	360	360	310	12x28	110	375	285	320	12x30	137

Sensor pockets

For Clorius V-thermostats

0-8.3.41-E

Page 1 of 2



APPLICATIONS

Sensor pockets of stainless steel can be supplied to all Clorius self-acting thermostats with rod sensors. They are used where it is impossible to empty the system or the tank. Use of sensor pockets imply delay of heat transfer to the rod sensors and thus a longer reaction time for the controllers. This is to some extent counteracted by filling up the sensor pockets with paste or oil.

MOUNTING

The installation site for the sensor pocket is arbitrary when paste is applied. When using oil the sensor pocket must point somewhat downwards.

FEATURES

- Secures quick heat transfer from media to the thermostat sensor
- Can be delivered with various flange connections as an option
- Protects the sensor
- Makes change of sensor easy

TECHNICAL DATA

Material	High alloy stainless steel Werkstoff No. 1.4436
Outer threads	BSP for all standard sensor pockets
Optional	Sensor pockets with NPT threads are only available for V.2.05 and V.4.05

PRESSURE/TEMPERATURE DIAGRAM

According to DIN 2401

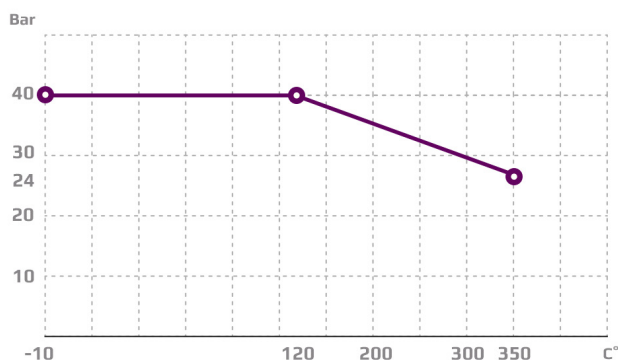

Subject to change without notice.

DIMENSION SKETCH

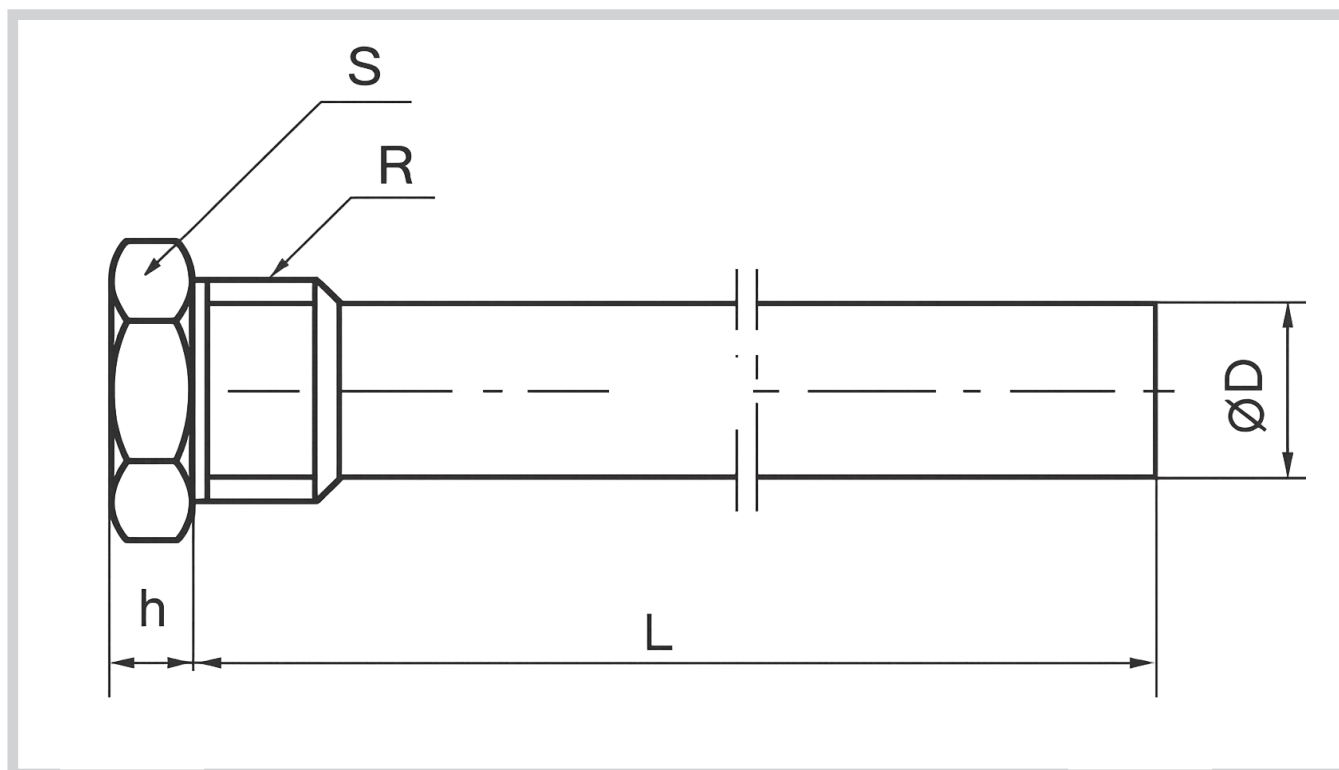

For thermostat type	Clorius product number	Dimensions in mm				ISO 7/1 (tapered)
		Ø D	L	h	S	
V 2.05	3290069	25	215	9	36	R 1
V 4.03	3290182			10	50	R 1¼
V 4.05	3290077	25	390	10	50	R 1¼
V 4.10	3290085	34	512	10	50	R 1¼
V 8.09	3290093	34	740	12	80	R 2½
V 8.18	3290204	38	805	12	80	R 2½



TECHNICAL DATA

Valve motor	
- Power supply	24 V AC +10/-15%, 50/60 Hz
- Consumption approx.	24 VA
- Casing	IP66
- Cable union	2xM20 1xM16
- Closing speed	15....30 sec.
- Ambient temp.	-10 to +55 °C
- Closing force	1100 N
- Stroke	0 – 40 mm
- Weight	5.6 kg
Control box	
- Transformer	230/24 V AC, 10 VA, 50/60 Hz
- Timer	10 sec.
- External alarm	Potential free switch
- Fuse	T 0.5 A / 250 V
Dual thermostat	
- Adjustable	35 – 95 °C
- Overheat protection	95 – 110 °C, Sealed at 105 °C, Manual reset
- Thread	½ RG
- Immersion-tube	110 mm

Subject to change without notice.

APPLICATIONS

Safety Set SM6 is developed for all Clorius valves up to 150 mm, but may be used for some other valve brands of corresponding size and function, too. It is consequently well suited for modernisation of existing systems.

FUNCTION

Safety Set SM6 is used for heating, cooling, ventilation and industrial systems, no matter whether the medium is water, steam or oil.

DESIGN

Safety Set SM6 consists of a valve motor, a control box and a dual thermostat. The valve motor is driven by a gear motor. Stepping motor with SUT (Superior Universal Technology) electronic control unit and electronic load-dependant cut-off.

The valve motor is delivered for 24 V AC/DC. The build-in spring return ensures a closing time of max. 4 sec. By temperatures higher than 130°C, a cooling unit (1-0152285) is to be mounted between valve and motor.

All gear wheels and bearings are life-time lubricated. Maintenance-free gear unit made of sintered steel; gearbox base-plate made of steel. The spring return is released when the power disappears from the holding coil, closing the valve completely. A timer in the control box ensures that the motor is not turned on again before 10 sec. after a spring return release. This function protects against starting the motor before the spring return function has terminated.

FEATURES

- IP66 (EN60529)
- Valve actuator with safety function (as per DIN EN 14597) and pushing force of 1100 N
- Easy to fit and self adjustable
- Spring return
- Simple assembly with valve; spindle is automatically connected after control voltage is applied (patented system)
- Lifetime lubricated gearbox
- 2-4 safety functions
- Direction of operation can be selected via screw terminals when making the electrical connection

THE CONTROL BOX CONTAINS:

- a 230/24 V AC transformer for the valve motor
- the 10 sec. timer for the spring return
- a potential free alarm switch
- terminal blocks for connections to the valve motor, the dual thermostat, other safety equipment, an alarm, and power
- a build-in fuse protecting against over-load and short-circuiting

The dual thermostat is set to the normal close-down temperature, e.g., 90°C, where the valve is to be closed. It further includes an overheating thermostat for spring return emergency close-down at 105°C. This ensures correct function, even if, e.g., the normal thermostat should fail. For additional safety, the overheating thermostat has to be reset manually after a break.

BUILD-IN SAFETY FUNCTIONS

Power failure

The build-in spring return closes the valve. When the power returns, the motor starts again after 10 sec. and moves the valve back to its original position.

Overheating protection

The spring return of the motor closes the valve on a signal from the 105°C overheating thermostat or other safety devices. The overheating thermostat has manual reset.

Other protections possibilities:

Against circulation failure

The motor closes the valve when a flow switch placed in the secondary circuit releases the spring return, e.g. by a pump failure. When circulation returns, the valve reopens automatically after 10 sec.

Against pressure failure

By means of a pressure switch the motor will release the spring return if the water pressure in the secondary circuit is reduced (static pressure).

ALARM FUNCTION

The build-in potential free alarm relay is activated at emergency close down (spring return).

DIMENSION SKETCH

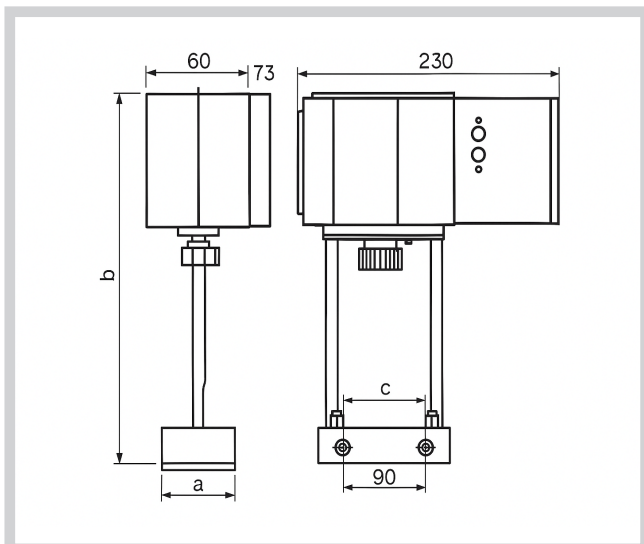

WIRING DIAGRAM, SAFETY SET SM6

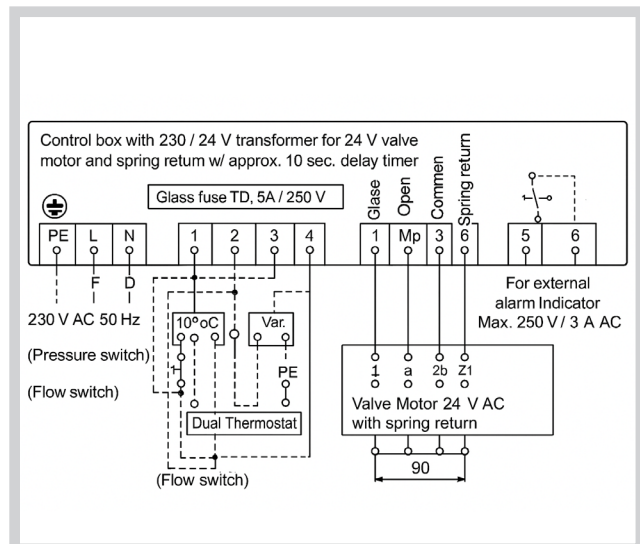

EQUIPMENT DIAGRAM

For steam/hot water heating systems, where the primary circuit is dimensioned for the maximum pressure of the steam/hot-water.

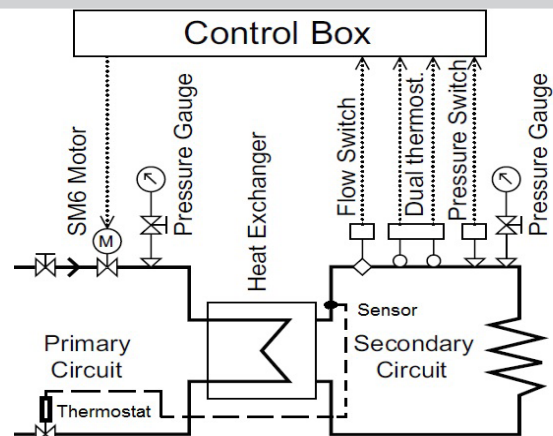

TYPE KS-4

Cooling unit protecting the stuffing box of the thermostat. To be applied at valve temperatures between 170°C and 250°C. For higher temperatures please see type KS-5.

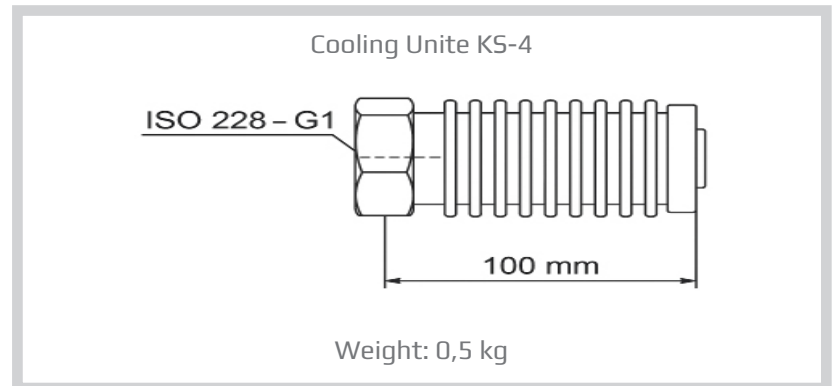

TYPE KS-5

Cooling unit with a built-in bellow gland, replacing the stuffing box of the thermostat. To be applied at valve temperatures between 250°C and 350°C.

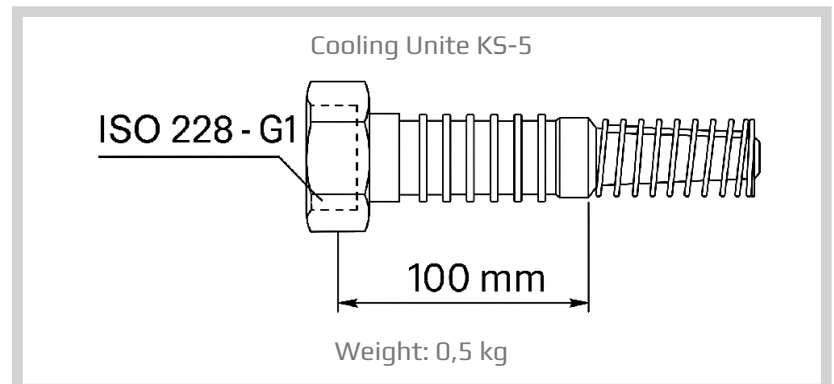

MANUAL ADJUSTING DEVICE

The device has a built-in thermostat stuffing box. For sealing and manual operation of valves when an actuator has not been fitted, e.g. during periods of construction (max. 170°C).

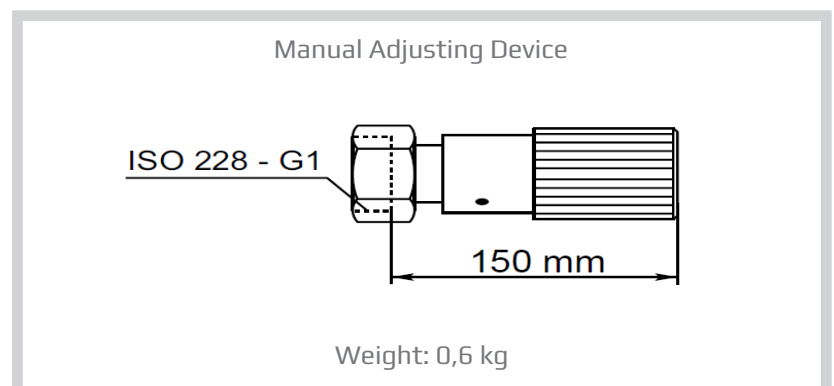

Spacer Concept (Machined and welded)

2 & 3 way control valves, DN 100, 125, 150, 200, 250 & 300

0-8.06.11-A

Page 1 of 2



Machined

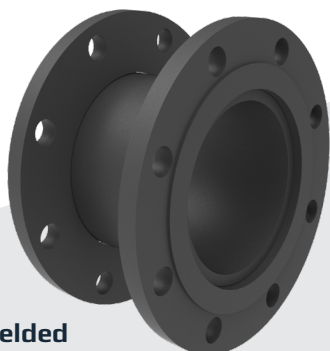

Welded

TECHNICAL DATA

Material:	
- Spacer	Steel 1.0570 (S355J2G3)
- Colour	Anthracite grey RAL 7016
Flange drilled according to:	
	EN 1092-2
- Option	JIS B 2210 5K/10K ANSI class 150
Available types:	Machined spacers Welded spacers
Available sizes:	DN 100 - DN300 DN 350, 400, 450 on request
Used for:	2 & 3 way control valves

APPLICATIONS

Spacer concept is designed for use together with all types of 2 & 3 way Clorius control valves.

FUNCTION

Spacers are available in both machined and welded types. Spacers are used to avoid changing the existing pipework when replacing old control valves with new control valves.

DESIGN

Spacers are available in machined design with a length from: <100mm for DN100 to DN300

Spacers are available in welded design with a length from: >100mm for DN100 to DN300

Spacers will be produced after piping & installation specifications.

Flanges are drilled according to the different flange standards: EN 1092-2, JIS 5K/10K & ANSI Class 150

FEATURES

- Spacers can be used in combination with all types of 2 & 3 way control valves
- Simple design manufactured according to the required flange standards
- Easy Installation - no modifications required to the existing installation

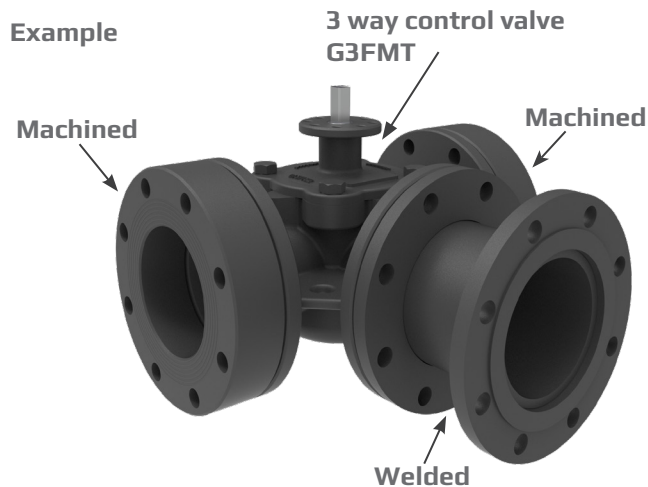

Subject to change without notice.

MACHINED VERSION

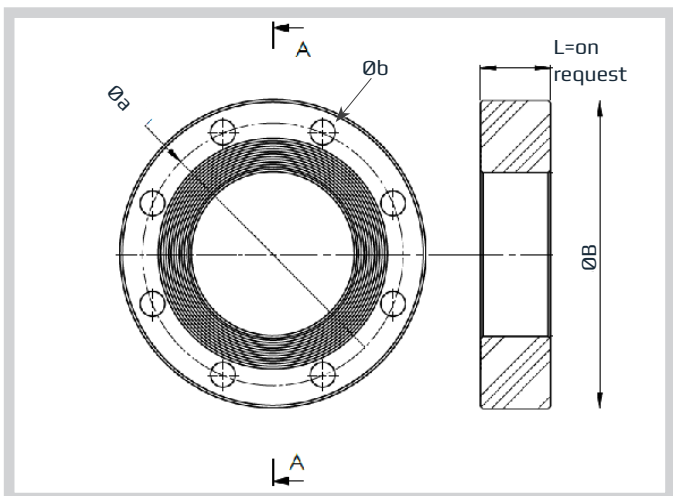

WELDED VERSION

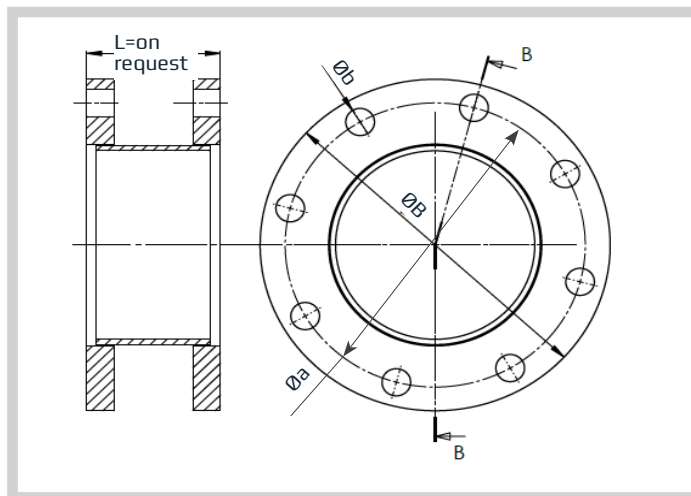

Flange connections	EN 1092-2			ANSI Class 150			JIS B 2210 5K			JIS B 2210 10K		
	B (dia.) (mm)	a (dia.) (mm)	b mm dia. (number)	B (dia.) (mm)	a (dia.) (mm)	b mm dia. (number)	B (dia.) (mm)	a (dia.) (mm)	b mm dia. (number)	B (dia.) (mm)	a (dia.) (mm)	b mm dia. (number)
DN100	220	180	19x(8)	230	191	19x(8)	200	165	19x(8)	210	175	19x(8)
DN125	250	210	19x(8)	255	216	22x(8)	235	200	19x(8)	250	210	23x(8)
DN150	285	240	23x(8)	280	241	22x(8)	265	230	19x(8)	280	240	23x(8)
DN200	343	295	22x(8)	343	298	22x(8)	320	280	23x(8)	330	290	23x(12)
DN250	405	350	23x(12)	405	362	25x(12)	385	345	23x(12)	400	355	25x(12)
DN300	455	400	23x(12)	483	432	25x(12)	430	390	23x(12)	445	400	25x(16)
*DN350	505	460	23x(16)	533	476	29x(12)	480	435	25x(12)	490	445	25x(16)
*DN400	565	515	28x(16)	597	540	29x(16)	540	495	25x(16)	560	510	27x(16)
*DN450	620	565	28x(20)	620	578	32x(16)	620	555	25x(16)	620	565	27x(20)

Spacers for DN350, 400, 450 are available on request.

Example



Installation of 3 way control valve GFMT with machined spacers and CAR-H actuator.



TERM & CONDITIONS

1. Application of terms of sale and delivery

1.1 The below general terms of sale and delivery shall apply for any quotation, order confirmation, sale and deliver by BROEN in the absence of any other agreement in writing between the parties.

2. Product information, price lists, etc.

2.1 Information in catalogues, price lists and any other product documentation provided by BROEN shall be binding on BROEN only where the agreement with the purchaser makes specific reference to such information. BROEN shall reserve the right to change information without notice.

2.2 All drawings and technical descriptions supplied to the purchaser shall remain the property of BROEN and may be used only for the operation and maintenance of the products supplied by BROEN. The material may not be copied, reproduced, passed on to or in any other way communicated to any unauthorized third part.

3. Prices and terms of delivery

3.1 Unless otherwise stated all prices in BROEN's quotations, order confirmations and other references are in Danish kroner (DKK) exclusive of VAT, customs duties, taxes, etc. Unless otherwise stated in the above material BROEN shall reserve the right to adjust prices until delivery in the event of changes in currency rates, customs duties, taxes or raw material prices.

3.2 Unless special terms of delivery have been agreed upon in writing, delivery shall be made in conformity with the Incoterms 2010, EXW. The prices stated by BROEN are in conformity with these terms of delivery.

3.3 The prices stated by BROEN are exclusive of the costs of packaging, including special packaging to ensure that the products are not exposed to damage in transit to the final destination. Unless otherwise agreed in writing, Euro pallets and pallet frames used will be invoiced the Purchaser. Return of Euro pallets and frames is not accepted.

3.4 For orders below Euro 300 net invoice value, or equivalent converted currency value, a handling fee of Euro 30 net, or equivalent converted currency value, applies.

4. Export

4.1 Unless otherwise agreed in writing it shall solely be the responsibility of the purchaser to ensure that the products sold can be legally applied in the purchaser's country and for the purposes intended, including their approval, if any, by public authorities or private persons for importation and application.

4.2 Unless otherwise agreed in writing, all costs of Irrevocable Letters of Credit (L/C) and costs of external produced verification documentation is to be carried by the purchaser.

5. Acceptance of quotations 5.1 Where BROEN makes a quotation that contains no stipulated date of acceptance, the quotation shall lapse in the event it is not accepted by the purchaser 30 days after the date of the quotation.

6. Time of delivery

6.1 Unless otherwise stated in writing in BROEN's quotation or order confirmation or in the agreement between the parties the time of delivery indicated by BROEN shall be indicated to the best of BROEN's judgment. In the event that the date of delivery is exceeded, the purchaser can by notification in writing to BROEN demand delivery and set a reasonable date not less than three weeks away. In the event that BROEN does not deliver within this extended period and where the non-delivery is not caused by circumstances attributable to the purchaser, the purchaser can by written notification to BROEN cancel the agreement with regard to the part consignment that has not been delivered. The purchaser shall not be entitled to make any claim vis-à-vis BROEN as a consequence of the delay.

6.2 In the event of strikes, lockouts, import restrictions, acts of God or other causes beyond BROEN's control, BROEN's time of delivery shall be extended by a period identical to the duration of the obstacle in question. Non-delivery or delayed delivery of raw materials from BROEN's sub-suppliers shall be considered acts of God and shall thus extend BROEN's time of delivery. In the event that the obstacle means that delivery cannot be effected or only at unreasonably high costs, BROEN shall retain the right to cancel the agreement

7. Terms of payment

- 7.1 Provided credit is approved, BROEN's terms of payment are current month from the date of invoice plus 30 days.
- 7.2 In the event of payment after the due date BROEN shall be entitled to charge interest on overdue payments, at present 1% per month, to be calculated from the due date. In addition to this there will be an administration fee for reminders of minimum Euro 30 net, or equivalent converted currency value (or the maximum amount allowed by law at any time).
- 7.3 Payment can only be effected to BROEN's address unless stated otherwise on the invoice.
- 7.4 The purchaser shall not be entitled to off-set any claim he may have against BROEN (unless this claim has been accepted by BROEN in writing) and shall not be entitled to retain part of the purchase amount on account of such counterclaims.

8. Retention of ownership

- 8.1 BROEN shall retain ownership of the products sold until payment in full has been effected with the addition of interest and possible costs. The purchaser shall not be entitled to make arrangements that limit BROEN's retention of ownership.

9. Invoicing

- 9.1 BROEN will issue and forward invoices electronically. In the event of purchaser requirement for printed and posted invoicing, a handling and postal fee of Euro 5 net, or equivalent converted currency value, applies.

10. Liability for defects and product liability

- 10.1 Immediately after delivery the purchaser shall examine the products received. Defects that are found or should have been found during this examination or defects that are found later shall without delay and not later than seven days after the defect is found or should have been found be communicated in writing to BROEN. The purchaser shall under no circumstances be entitled to claim compensation for defects from BROEN later than one year after the date of delivery.
- 10.2 BROEN shall be entitled to decide whether the defects can be repaired or the defective products must be replaced. Such replacement and/or repair of defects will be made as soon as possible after the return of the product to BROEN.
- 10.3 The purchaser shall only be entitled to return sellable standard products and only following prior acceptance in writing from BROEN. BROEN reserves the right to refuse return of products at BROEN's sole discretion. The freight costs of the returned products shall be paid by the purchaser. The reimbursement for returned products shall be calculated on the basis of the original sales price with a deduction reflecting the costs of preparing the products for a new sale. This deduction will be fixed after the receipt of the products and after an assessment of the state of the products, the deduction will, however, amount to minimum 30% of the sales price.
- 10.4 Apart from the stipulations of clause 10.1/10.2 the purchaser shall not be entitled to make any claims to BROEN on account of defective products. 10.5 BROEN shall be liable for injuries to persons and damage to property as a result of defects in the products supplied (product liability) solely to the extent laid down in non-dispensable rules of law. BROEN shall not be liable for damage to the purchaser's real or personal property or to any other real or personal property belonging to a third party intended for commercial use.
- 10.6 Particularly for brass products it must be emphasized that BROEN shall not be liable for damage to the products or damage attributable to the products as a result of stress corrosion, dezincification and galvanic corrosion unless BROEN has in writing taken on such liability. In the event that BROEN has taken on such liability these general terms of sale and delivery shall apply with the exception of this clause.

11. Exemption from liability

- 11.1 BROEN shall be exempt from liability to the purchaser in the event of circumstances that prevent the fulfilment of the agreement or that make the fulfilment unreasonably burdensome, such as labour conflicts and any other circumstances beyond the control of BROEN, e.g. fire, war, mobilisation or similar military measures, seizures, currency restrictions, riots and civil unrest, lack of means of transportation, general scarcity of goods, restrictions regarding motive power as well as defective or delayed deliveries from sub-suppliers due to any of the circumstances mentioned in this clause.
- 11.2 BROEN shall under no circumstances be liable for trading losses, losses of profit or other indirect losses or other consequential losses, including the costs of establishing or localizing defective products or damage.

12. Settlement of disputes - venue

- 12.1 Any dispute between BROEN and the purchaser in relation to an agreement between the parties or in relation to the interpretation of these general terms of sale and delivery shall be settled in accordance with Danish law and at BROEN's venue. BROEN shall be entitled to demand that any dispute is settled by arbitration in accordance with the rules and stipulations of the Danish Institute of Arbitration (Det Danske Voldgiftsinstitut).
- 12.1 Any dispute between BROEN and the purchaser in relation to an agreement between the parties or in relation to the interpretation of these general terms of sale and delivery shall be settled in accordance with Danish law and at BROEN's venue. BROEN shall be entitled to demand that any dispute is settled by arbitration in accordance with the rules and stipulations of the Danish Institute of Arbitration (Det Danske Voldgiftsinstitut).



Headquarters
BROEN - CLORIUS
Skovvej 30
DK-5610 Assens

+45 77 32 31 30
mail@cloriuscontrols.com

APRIL 2026 - EDITION 19

SALES REPRESENTATION

Clorius Controls Division - CHINA
Room 1910-1911, Unicom International Tower,
NO 547 West Tian Mu Road
Shanghai 200070 P.R. China
Tel: +86 21 33 030 279 // +86 21 33 035 279

BROEN - CLORIUS - POLAND
BROEN SA
ul. Strefowa 19
58-200 Dzierżonów
Poland
Tel: +48 74 832 54 00